

VOICE ALARM DC LINE MONITOR

VIGIL 2



The DC line monitor isolator units are CANBUS modules for the VIGIL2 voice alarm system, consisting of two components:

BVRDADIM • BVRDADIS

FEATURES:

- Enables dual loudspeaker circuits to connect to a single amplifier.
- Each BVRDADIS unit provides both A&B circuits for two amplifiers.
- Up to 10 spurs per loudspeaker line.
- The BVRDADIM master unit connects to the BVRD2M router.
- Up to five BVRDADIS can be connected to one BVRDADIM.
- Fitting five BVRDADIS enables broadcast and monitoring for up to twenty loudspeaker circuits.
- The modules plug directly together.
- Utilises DC line monitoring techniques, therefore BEL1 end of line monitoring is not required. (Please refer to 'system requirements'.)
- Failure of either the A or B circuit from one amplifier will not effect the other circuit.
- In the event of an amplifier failure, reserve amplifiers will automatically operate.
- With five BVRDADIS fitted, a one-in-ten amplifier changeover ratio is enabled.
- Reduces rack size and cost for large voice alarm systems
- Earth leakage protection.

SYSTEM REQUIREMENTS:

- Maximum of 225W load per loudspeaker line.
- Each loudspeaker requires a capacitor (refer to table below). We recommend that you take advice from your loudspeaker supplier.
- Each end-of-line loudspeaker requires a 10K 2W (at 1% tolerance) resistor fitted across the line. (Available in packs of ten - product code BVRDADCR.)

Speaker Wattage	Capacitor requirement
6 Watts	1 μ f 250V DC
15 Watts	2.2 μ f 250V DC
30 Watts	4.7 μ f 250V DC
60 Watts	10 μ f 250V DC

SYSTEM DESIGN:

System design is part of our commitment to provide a complete service from the initial planning stage through installation to after-sales technical support.

Our extensive range of standard products has been designed to accommodate most installation requirements. However our experienced design team often cater for projects that require bespoke solutions.

If you require any assistance with our products, or help with system design, please contact sales@baldwinboxall.co.uk.

TYPICAL APPLICATION:

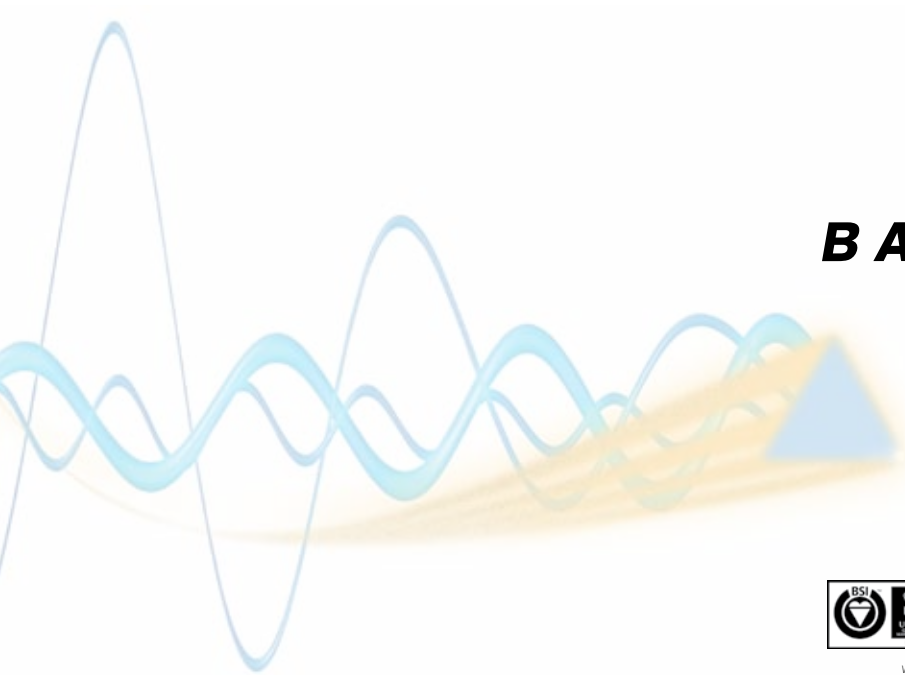
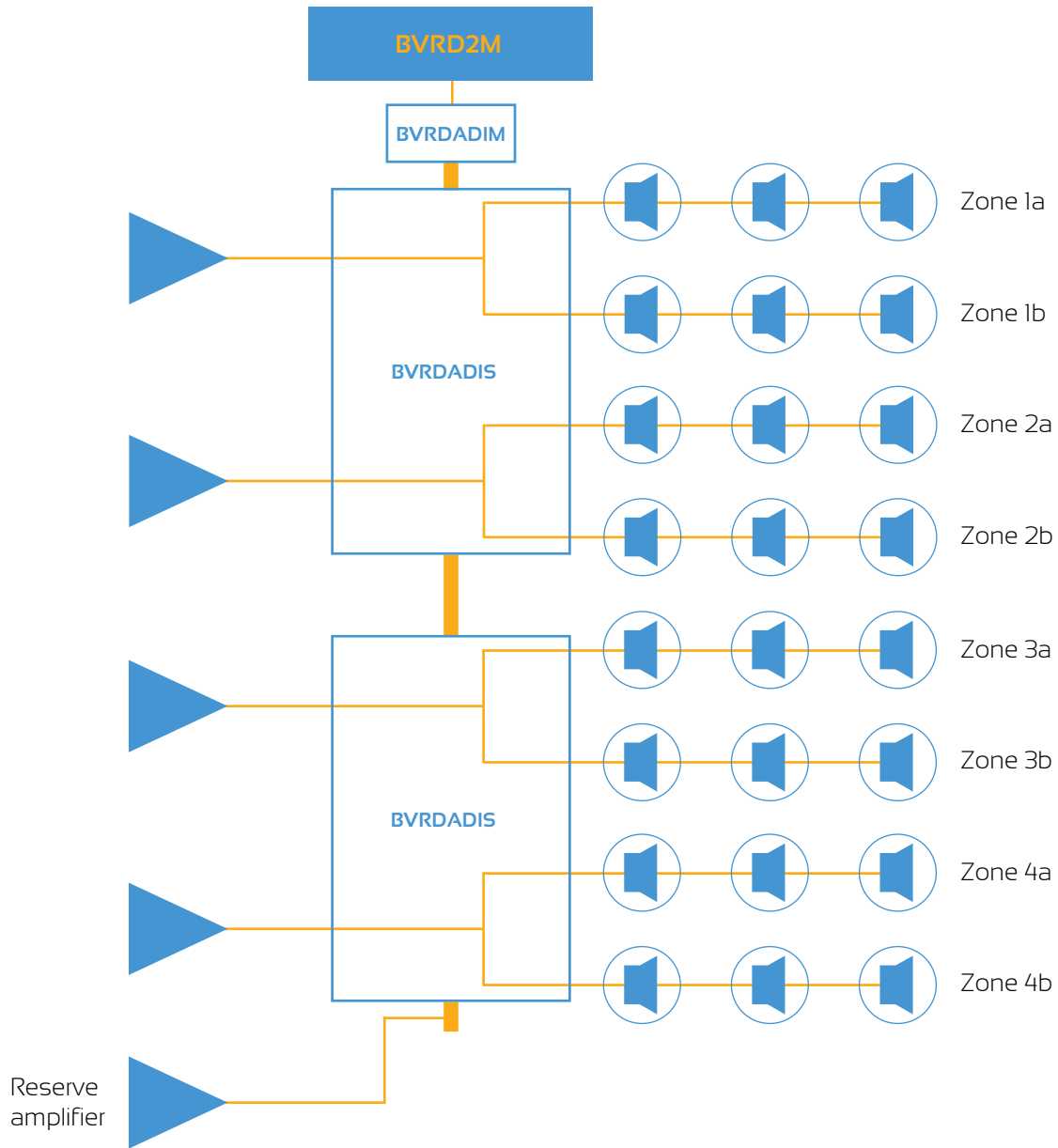

BALDWIN BOXALL

TEL: +44 (0) 1892 664422
 FAX: +44 (0) 1892 663146

EMAIL: MAIL@BALDWINBOXALL.CO.UK
 WEB: WWW.BALDWINBOXALL.CO.UK

BALDWIN BOXALL COMMUNICATIONS LTD
 WEALDEN INDUSTRIAL ESTATE,
 FARNINGHAM ROAD, CROWBOROUGH,
 EAST SUSSEX, TN6 2JR, UNITED KINGDOM.



WE RESERVE THE RIGHT TO CHANGE THE PRODUCT SPECIFICATION WITHOUT PRIOR NOTICE OR LIABILITY. DOC NO: 1.0034.07.11