

## MICSUV

# Operating Instructions

**Baldwin Boxall Communications Ltd.**

Wealden Industrial Estate, Farningham Road  
Crowborough, East Sussex, TN6 2JR

Telephone: 01892 664422 Fax: 01892 663146

Website: [www.baldwinboxall.co.uk](http://www.baldwinboxall.co.uk)

Email: [mail@baldwinboxall.co.uk](mailto:mail@baldwinboxall.co.uk)

**BALDWIN BOXALL**  
COMMUNICATIONS

# **MICROPHONE PREAMPLIFIER MODULE WITH SURVEILLANCE FOR VOICE ALARM SYSTEMS**

Please refer to Figure 1 for DIL Switch locations and connection details.

The MICSUV is a versatile microphone preamplifier module that can provide surveillance, a dynamic limiter and selectable gain to suit any installation.

## **SURVEILLANCE**

The MICSUV injects a surveillance signal directly into the microphone capsule therefore monitoring the microphone, the preamplifier and the interconnecting audio cable.

The unit also monitors the Access cable and connection. This is achieved by enabling the internal signal generator only when a DC bias is present on the Emergency Access terminal. This ensures the cables between the main equipment Input Access and the Emergency Access terminal are monitored. The surveillance signal can be selected to either 20KHz or 1.5KHz depending on the requirements of the installation by setting SW2.2 (see fig 1 for details).

VR1 can be adjusted to provide the required surveillance signal output level.

When the Press to Talk switch is operated this signal is suppressed, and to prevent faults being announced the IMP18 fault detector modules can be 'frozen' (see fig 1).

## **LIMITER AND GAIN SETTINGS**

The MICSUV module includes a Dynamic Limiter and has selectable gain.

The limiter ensures that the maximum audio output signal remains constant irrespective of input level change, which can help prevent the system overloading when different personnel use the microphone. See Fig 1 for details.

The gain of the module can be either 50dB or 70dB depending on the installation requirements. The 70dB setting is more suitable for driving long cable lengths.

## **EXTERNAL CONNECTIONS AND INDICATORS**

See Fig 1 for details.

The MICSUV provides two open collector outputs that can be used to directly drive a 'Fault' LED and a 'Speak Now' LED.

The 'Fault' LED will flash and an internal buzzer will sound if the 'Fault Input' is not connected to +24V. This 'Fault Input' should be connected to the main equipment fault relay contacts which under normal (i.e. non fault) conditions, is connected to 24V.

If a fault is detected then the 'Fault Accept' terminal should be switched momentarily to 24V. By accepting a fault the buzzer will be muted and the LED will illuminate continuously instead of flashing.

If this facility is not required then the 'Fault Input' terminal should be connected to pin 3 (24V supply).

The 'Speak Now' LED illuminates to inform the user that the system is ready for an announcement.

If a chime is fitted then SW2.1 should be set to 'ON'. This will delay the LED from illuminating and mute the microphone for 2.5 seconds to allow the chime to finish before the announcement can be made. On systems without a chime SW2.1 should be set to 'OFF'.

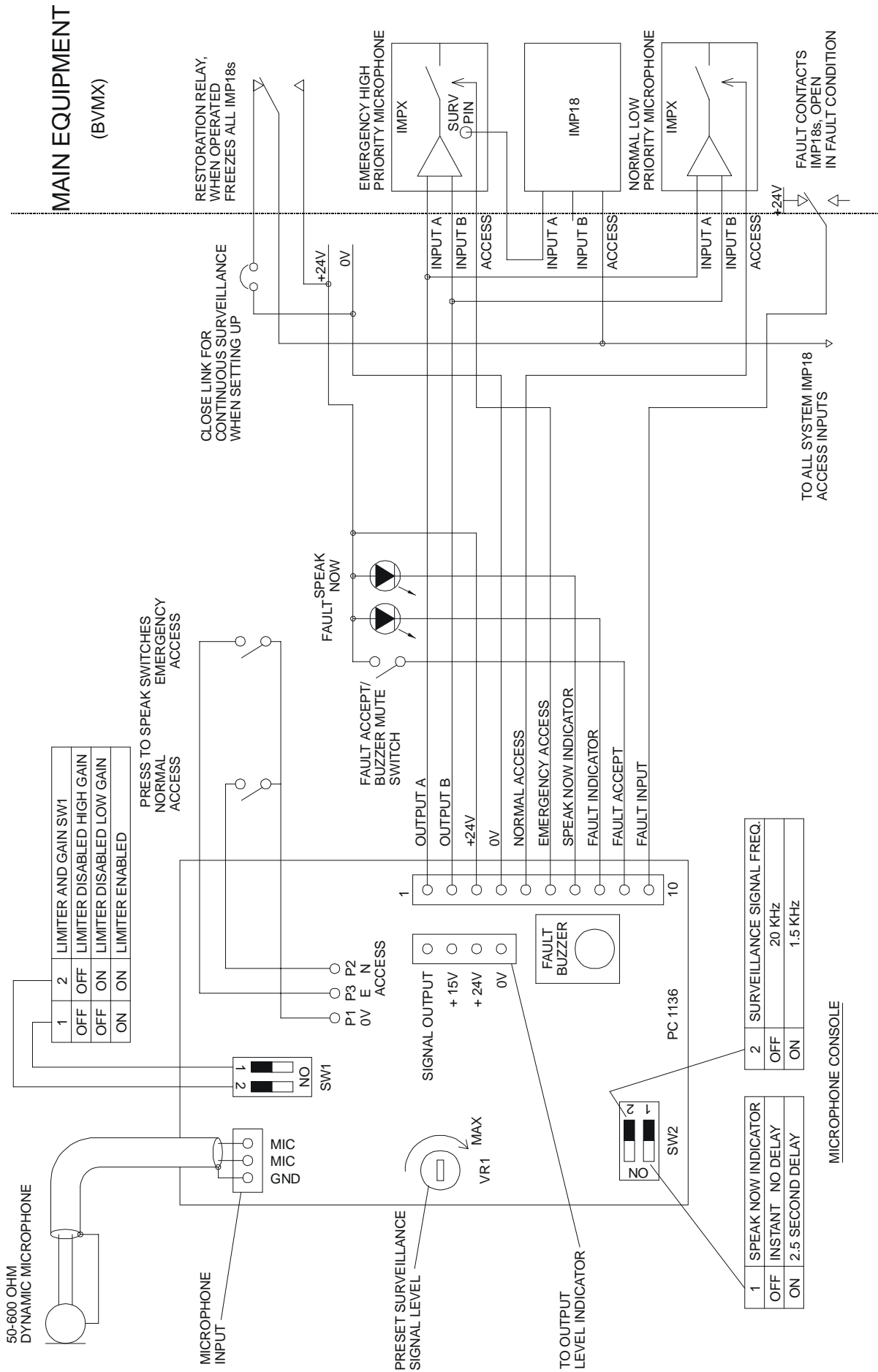

**Fig 1: Connection Details for a Typical Monitored Microphone using a MICSUV, an IMPX, and an IMP18**

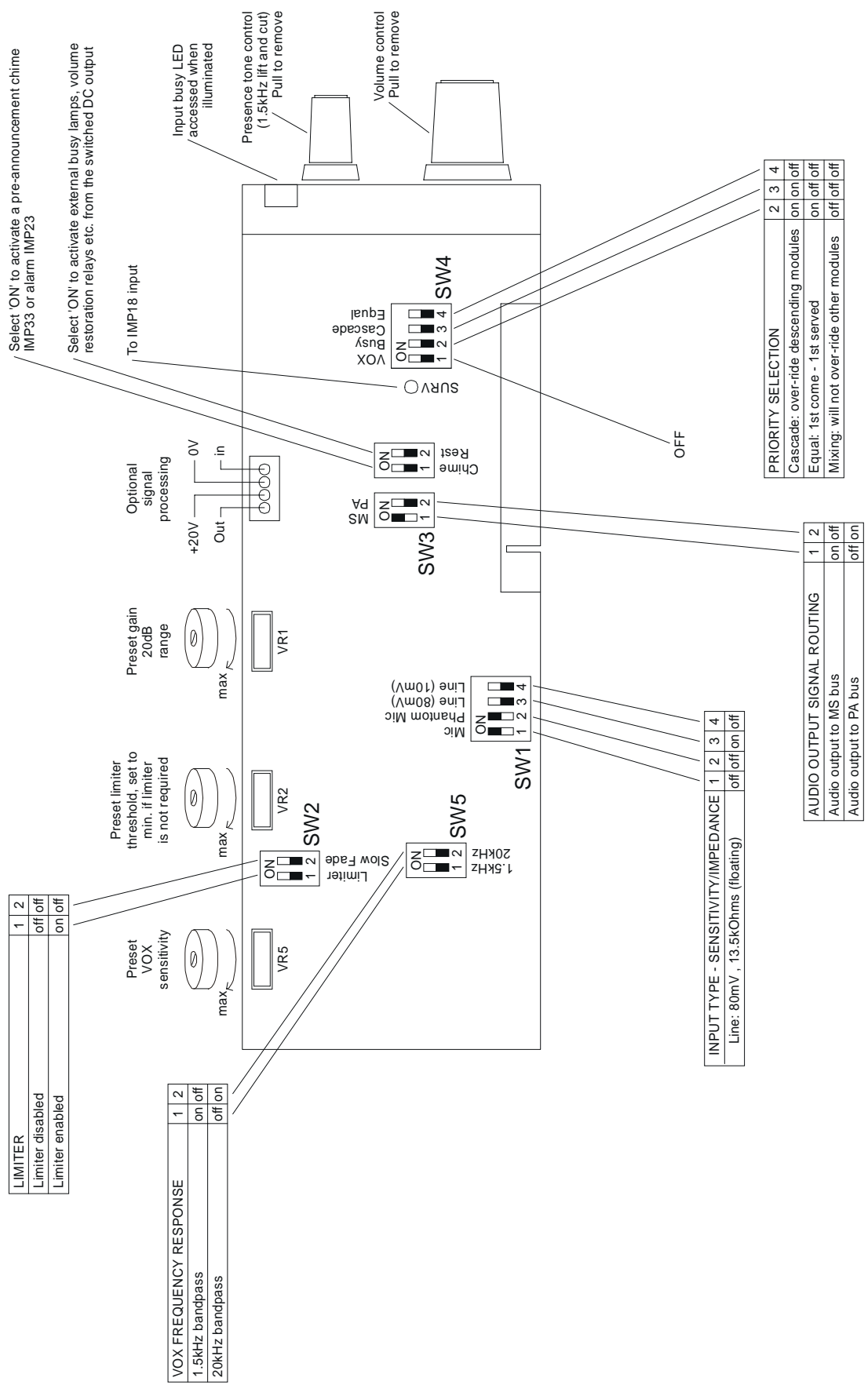

**Fig 2: IMPX Connector and Switch Settings when using MICSUV**

## INSTALLATION

The MICSUV is often installed in our BDM range of paging microphones to enable monitoring when used in a Voice Alarm system.

As installation of a MICSUV in a BDM microphone requires component changes and modifications to the microphone it is a preferred 'Factory Fit' option.

We recommend that if a MICSUV is to be retro-fitted than both units should be returned to us for assembly and testing.

The diagram below shows how the module should be connected and details of the component changes, but as this is a 'Factory Fit' option it is for illustrative purposes only.

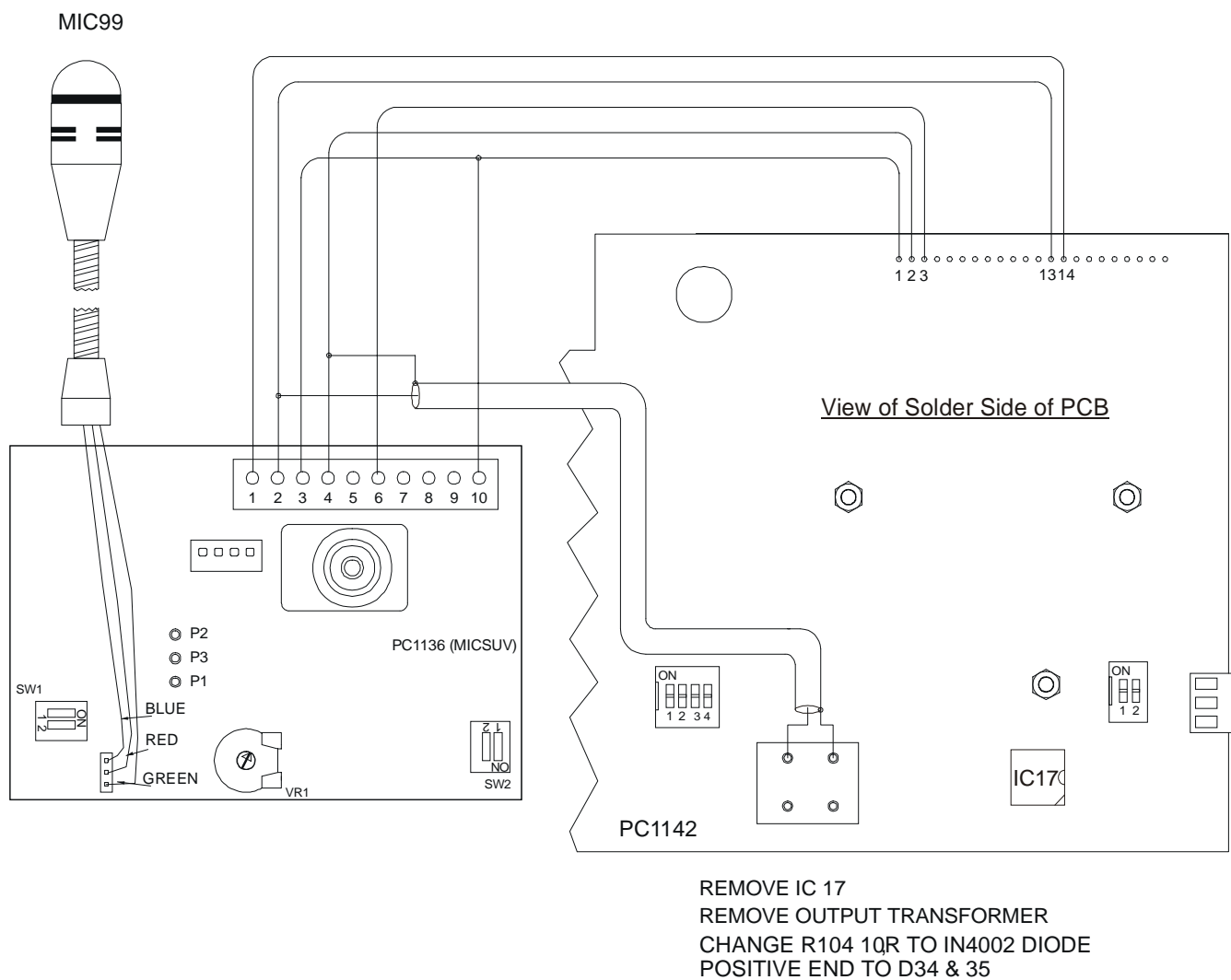

**Fig 3: Connection details for installing a MICSUV in a BDM208 or BDM216**

Please note: when a MICSUV is fitted to a BDM microphone care must be taken to ensure the "Mic / Line" DIL switches are set to LINE.

If the switches are set to MIC the output will be attenuated which could cause surveillance faults.

**SWITCH SETTINGS FOR MICSUV WHEN USED WITH  
IMPX AND IMP18 COMBINATION**

**MICSUV**

	SW1.1	SW1.2
Is the limiter required?	On	Off
	Off	On

	SW2.1
Is a Chime fitted?	On
	Off

	SW2.2
Surveillance frequency required	On
	Off

**Note:** set VR1 Preset Surveillance output level halfway

**IMPX**

	SW1.1	SW1.2	SW1.3	SW1.4
Set to 80mV line input	Off	Off	On	Off

	SW2.1	SW2.2
Set to Disable limiter	Off	Off

**Note:** if a limiter is required the one on the MICSUV should be used

	SW3.1	SW3.2
Set audio output path (MS or PA)	On	Off
	Off	On

	SW4.1	SW4.2	SW4.3	SW4.4
Set Priority Mode	Off	On	On	Off

**Note:** emergency microphones generally have cascade priority

	SW5.1	SW5.2
Set surveillance filter frequency	On	Off
	Off	On

**Note:** this should be same frequency as step 3 on MICSUV above

	SW6.1
Does this Microphone have a chime (IMP33) or Alarm (IMP23) fitted.	On
	Off

	SW6.2
Set to enable volume restoration	On

**Note:** it is necessary to 'freeze' the IMP18s using the restoration relay when input is accessed.

## BRIEF SETTING UP PROCEDURE FOR MICSUV AND IMPX COMBINATION

1. Set the preset gain control on the MICSUV to mid position.
2. Set the preset VOX control on the IMPX fully anti-clockwise (to minimum).
3. Set system volume controls for the required sound pressure output.  
If the overall system gain is too high or low adjust the IMPX preset gain control to compensate.
4. Set the presence tone control for best speech intelligibility.
5. Set the associated IMP18 to “CONTINUOUS SURVEILLANCE” mode.  
The fault buzzer and LED should now operate.
6. Slowly adjust the IMPX preset VOX sensitivity until the microphone fault condition resets.

### MICSUV SPECIFICATION

SW1 setting	SW1.2 = OFF	SW1.2 = ON
<i>Input sensitivity for 0.775V 0dBm output</i>	: -70dB 240uV	-50dB 2.4mV
<i>Max Output level</i>	: +21dB 8.7V	+21dB 8.7V
<i>Frequency response -3dB</i>	:80Hz - 18KHz	
<i>Output Noise ref to 0dBm</i>	:50dB	67dB
<i>Max Surveillance signal output 1.5khz</i>	:4.1V	410mV
<i>Max Surveillance signal output 20khz</i>	:1.7V	170mV
<i>Output source impedance.</i>	:20 Ohms	
<i>Limiter selected SW1 1 = ON, 2 = OFF</i>		
<i>Input level required to onset limiting</i>	:1mV	
<i>Output level for 10mV input.</i>	:+13.5dB 3.7V	
<i>Max input level.</i>	:400mV	