

BVRDADIM

Utilising Firmware V1.02

Operation Manual

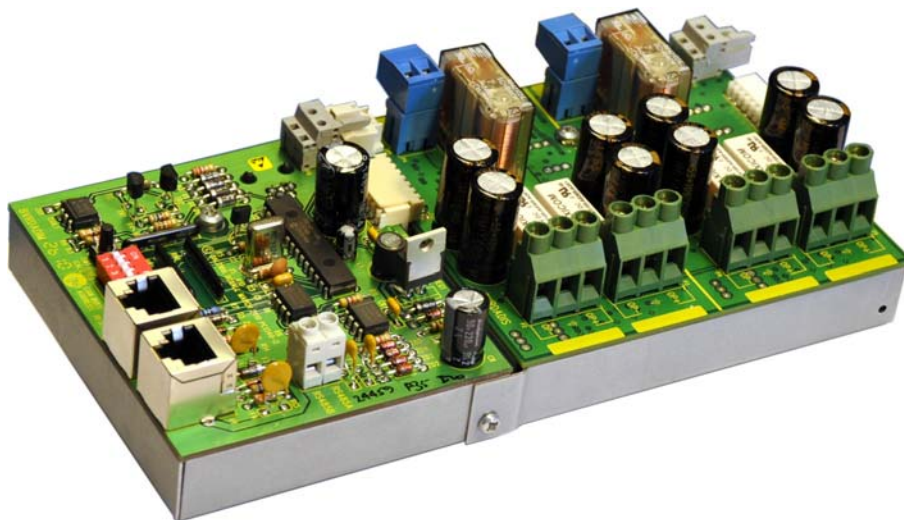

Baldwin Boxall Communications Ltd.
Wealden Industrial Estate, Farningham Road
Crowborough, East Sussex, TN6 2JR

Telephone: 01892 664422

Fax: 01892 663146

Website: www.baldwinboxall.co.uk

Email: mail@baldwinboxall.co.uk

BALDWIN BOXALL
COMMUNICATIONS

VIGIL BVRDADIM

Description of unit

The Vigil BVRDADIM is a loudspeaker line monitor and amplifier changeover unit, with independent Monitoring and Isolation for two Loudspeaker circuits per Amplifier.

The unit enables an interleaved A-B loudspeaker circuit to be driven from a single amplifier.

Each unit is supplied as a DIN rail-mounting module, with screw terminals for connections to the amplifiers and loudspeaker lines. Connection to the BVRD2M is by CAN BUS ports.

Amplifier changeover function

Each BVRDADIS expansion module enables two Amplifiers (and four Loudspeaker lines) to be monitored. The BVRDADIM can monitor up to five BVRDADIS modules (making a total of ten amplifiers and twenty loudspeaker circuits) and a Reserve Amplifier.

If an amplifier were to fail the BVRDADIM automatically detects the faulty amplifier and switches the relevant outputs over to the reserve amplifier until the fault has been rectified. A fault will be displayed on the BVRD2M front panel and also stored in the BVRD2M fault log.

When the faulty amplifier has been replaced it is necessary to press the "Fault Reset" button on the front of the BVRD2M to restore the system and stop using the reserve amplifier.

Loudspeaker line monitor function

Each loudspeaker spur (maximum 10 per circuit) must have a 10KΩ End of Line Resistor fitted in parallel with the last physical loudspeaker on the line. All loudspeakers must be fitted with a DC Blocking capacitor, see illustration below for details.

The BVRDADIM monitors the integrity of the Loudspeaker Line by measuring a small DC current flowing through the End of Line resistors. Any change in this current indicates either a short circuit or open circuit condition on the loudspeaker line and a fault will be indicated

If one CCT suffers from a Short Circuit the BVRDADIM will isolate the affected CCT, allowing the other CCT to function and a fault will be indicated. Earth faults are also detected and indicated.

Component	Description	Value
DC Blocking Capacitor	Non Polarised	2.2uF 250V
End of Line Resistor	High Stability	10KΩ 2W 1%

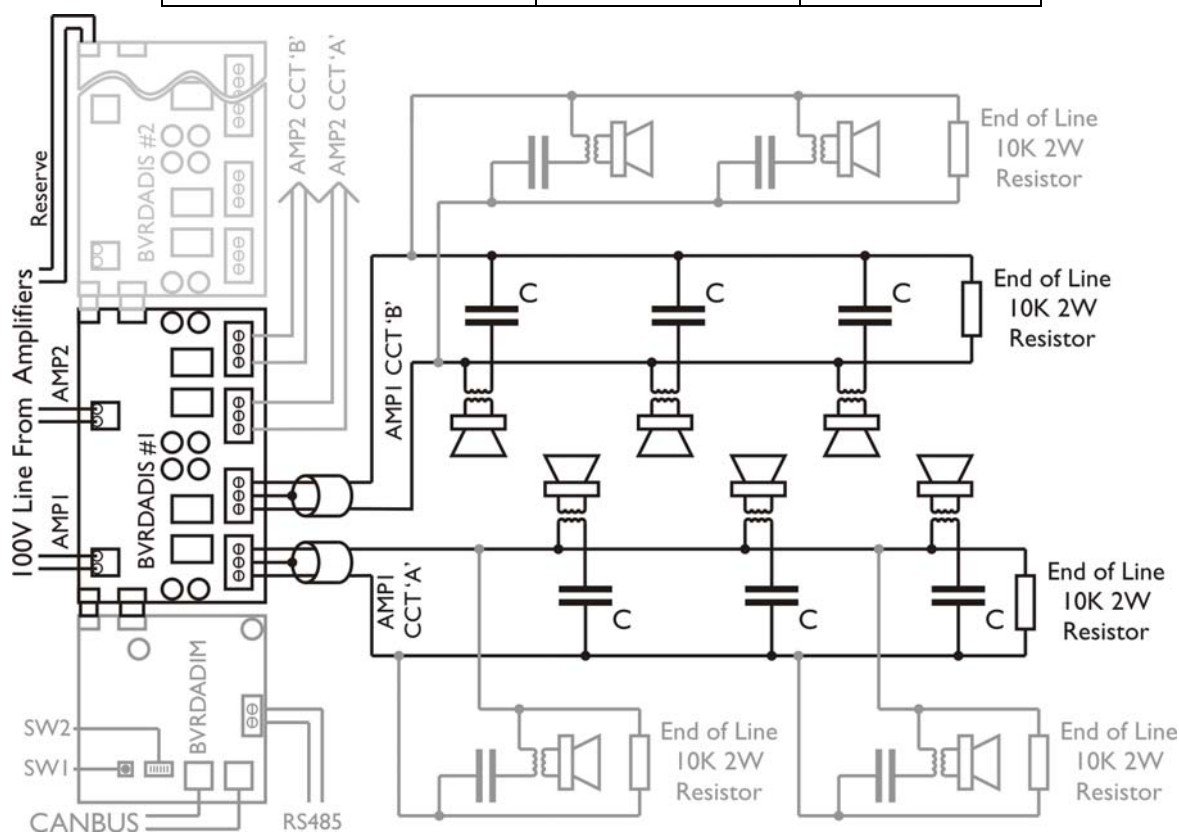

BVRDADIM Installation Procedure

Calibration (All Lines)

- 1 Ensure all individual loudspeakers are fitted with a DC Blocking Capacitor and tapped to produce the required maximum sound level.
Ensure the End of Line resistor(s) are the correct value and connected in parallel with the last loudspeaker on each loudspeaker line (on the line side of the DC Blocking capacitor).
- 2 Disconnect the individual loudspeaker line(s) from the BVRDADIS module.
- 3 Using an impedance meter set to 1kHz, measure and record the impedance. Ensure the load does not exceed the amplifiers rating.
- 4 Using a digital multi meter, measure and record the DC resistance. Divide this value into 10,000 and ensure the result equals the number of End of Line resistors connected.
- 5 Reconnect the line to the appropriate output terminals on the BVRDADIS module.
- 6 Repeat steps 1 to 5 for all lines to be connected to the BVRDADIS modules.
- 7 Set DIL SW2.1-2.5 to "OFF".
- 8 Ensure the BVRDADIM is operating (LED1 Flashing) and wait approximately 60 seconds to allow the BVRDADIM to cycle through the calibration process for all lines.
- 9 Set SW2.5 to 'ON'.
Press the Calibrate Switch (SW1) to set the calibrate reference for all 10 lines.
- 10 Set SW2.5 'OFF' to enable normal operation.

Note: SW2.6 selects the CANBUS termination resistor. This is normally set to "OFF".

Calibration (Selected Lines only)

To calibrate an individual pair of lines select the required lines using SW2.1 – 2.5 as shown below and press the calibrate switch:

SW2						Lines
1	2	3	4	5	6	
1	0	0	0	1	0	1A & 1B
0	1	0	0	1	0	2A & 2B
1	1	0	0	1	0	3A & 3B
0	0	1	0	1	0	4A & 4B
1	0	1	0	1	0	5A & 5B
0	1	1	0	1	0	6A & 6B
1	1	1	0	1	0	7A & 7B
0	0	0	1	1	0	8A & 8B
1	0	0	1	1	0	9A & 9B
0	1	0	1	1	0	10A & 10B
X	X	X	X	1	0	All lines

After calibrating return SW2.1 – 2.4 to the required address (as shown in the next section) and ensure SW2.5 is set to "OFF".

Set Address

To enable the BVRDADIM module to communicate with the BVRD2M it requires a unique CANBUS address to be set using SW2.1 – 2.4 as shown below.

Note: Ensure that SW2.5 is set to 'OFF'.

SW2						Canbus Address	RS485 Port #
1	2	3	4	5	6		
0	0	0	0	0	0	0	3
1	0	0	0	0	0	1	4
0	1	0	0	0	0	2	5
1	1	0	0	0	0	3	6
0	0	1	0	0	0	4	7
1	0	1	0	0	0	5	8
0	1	1	0	0	0	6	9
1	1	1	0	0	0	7	10
0	0	0	1	0	0	8	--
1	0	0	1	0	0	9	--
0	1	0	1	0	0	10	--
1	1	0	1	0	0	11	--
0	0	1	1	0	0	12	--
1	0	1	1	0	0	13	--
0	1	1	1	0	0	14	--

RS485 Port Address

The BVRDADIM module includes an RS485 port.

The address of this port depends on the CANBUS address selected as shown in the table above.

Operation of the BVRDADIM with the BVRD2M

The BVRD2M will display the following messages if a Line / Amplifier fault is detected:

"L/S Line O/C"	The system has detected a change (either OPEN or SHORT circuit) on CCT A.
"L/S Line S/C"	The system has detected a change (either OPEN or SHORT circuit) on CCT B.
"AMP FAULT"	The system has detected an Amplifier Fault. The Reserve Amplifier will be switched in (if enabled and available).
"RES AMP"	The system has detected a fault with a Reserve Amplifier (if enabled)
"GND FAULT"	The system has detected a loudspeaker line connected to Ground (Earth).

Note: Intermittent amplifier surveillance must be set for a maximum of 20 seconds to prevent spurious Amplifier Faults being reported.