



OPERATING INSTRUCTIONS

BALDWIN BOXALL
COMMUNICATIONS

VIGIL EVAS BVRD2M

Operating Instructions



Manual name: BVRD2M

Issue: 1

ECN: --

Date of issue: September 2007

© September 2007 Baldwin Boxall Communications Limited

Wealden Industrial Estate
Farningham Road, Jarvis Brook
Crowborough
East Sussex
TN6 2JR
UK

Telephone: +44 (0)1892 664422

Facsimile: +44 (0)1892 663146

Email: mail@baldwinboxall.co.uk

Website: <http://www.baldwinboxall.co.uk>



This equipment has been designed and manufactured to conform to the following EC Standards:

EMC: EN55103-1 Environment Classification: E1,

EMC: EN55103-2 Environment Classification: E5,

Safety: EN60065

Failure to use the equipment in the manner described in the product literature will invalidate the conformity.

A "Declaration of Conformity" statement to the above standards and a list of auxiliary equipment used for compliance verification is available on request.

Amendment Record _____	vii
Proprietary Notice _____	vii
Safety Information _____	viii
Comments _____	viii

Introduction

BVRD2M Technical Description _____	1
Front Panel Controls & Settings _____	2
Rear Panel Connections _____	3
BVRD2M Specifications _____	4
Audio Input Specifications - - - - -	4
Audio Output Specifications - - - - -	5
Control Inputs / Outputs - - - - -	5
BVRD2S Slave Unit _____	6
Main Features - - - - -	6
Rear Panel Connections - - - - -	6
BVRD2M CANBUS Modules _____	7
BVRDACO - - - - -	7
BVRDFPI - - - - -	7
BVRDCI - - - - -	7
Simplified Schematic Diagrams _____	8
BVRD2M & BVRD2S Schematic Diagrams - - - - -	8
CAN BUS Module Schematic Diagrams - - - - -	10
Typical Installation Examples _____	14

Hardware Installation

Attaching Slave unit(s) _____	17
-------------------------------	----

Operating Instructions

Introduction _____	19
Front Panel Navigation Controls _____	20
Access Levels _____	21
Navigating the Menu Structure and Setting Parameters _____	22
Illustrations of the Menu Structure - - - - -	23

System Configuration - Audio Settings

Audio Input Settings	31
General Description - - - - -	31
Audio Input Configuration - - - - -	32
Input Attenuation setting _____	32
EQ Settings (including Low, High and High Pass Filters) _____	32
Chime Settings _____	34
Compressor / Limiter Settings _____	35
Surveillance Level & Surveillance Priorities _____	35
Fade Recovery Settings _____	36
Audio Output Settings	37
General Description - - - - -	37
“Zone” Audio Output Configuration - - - - -	37
Level/Priority Settings _____	38
EQ Settings _____	39
Ambient Noise Sensing / Night Volume _____	40
Audio Output Delay Settings _____	42
“Listen” Audio Output Configuration - - - - -	43
“Reserve” Audio Output Configuration - - - - -	44
DVA Message Settings	46
General Description - - - - -	46
DVA Message Configuration - - - - -	46
Chimes	47
General Description - - - - -	47
Chime Configuration - - - - -	48
Bypass Inputs	49
General Description - - - - -	49
Bypass Configuration - - - - -	50
Input 01 Bypass Configuration _____	50
Input 02 Bypass Configuration _____	51
Emergency Message Configuration _____	51
Entering or Changing Names of Inputs / Outputs etc	52

System Configuration - Control Settings

General Description	55
Opto-coupled Inputs - - - - -	56
Analogue Control Inputs - - - - -	56
Simple Contact Closure Inputs - - - - -	57
PTT Priority - Multiple Inputs to Single Output _____	57

Open Collector Outputs - - - - -	57
Control - Input Configuration _____	58
Opto EM Input Configuration - - - - -	58
Opto nn Input Configuration - - - - -	59
Route Settings _____	60
Analogue Input Configuration - - - - -	61
Analogue Access Input _____	62
PTT Input Settings _____	63
Fault Input Settings _____	63
Remote DC Volume Settings _____	64
Ambient Noise Input Settings _____	64
Contact Input Configuration - - - - -	65
Contact Input Access Menu _____	66
PTT Contact Input Menu _____	66
Fault Contact Input Menu _____	67
VOX Input Configuration - - - - -	68
Control - Output Configuration _____	69
Zone Output Busy Configuration - - - - -	70
Audio Input Busy Configuration - - - - -	70
Fault Busy Configuration - - - - -	70
Control - Amplifier Surveillance Configuration _____	71
Surveillance Configuration - - - - -	71
Surveillance Level Configuration - - - - -	72
Surveillance Frequency Configuration - - - - -	72
Surveillance Fault Priority Configuration - - - - -	72
DC Line Surveillance - - - - -	73
Control - RS485 Port Configuration _____	74
ID# Configuration - - - - -	75
Type Configuration - - - - -	75
Button Configuration - - - - -	75
Settings Configuration - - - - -	76

System Configuration - Time, Date and Text Settings

Setting the Time & Date _____	78
Text Entry (Installation name & Service Information) _____	79
Installation Name Entry - - - - -	79
Service Information Entry - - - - -	80

AMENDMENT RECORD

Page Number(s) Affected	Change Note Number	Nature of Amendment	Date of Amendment
All	--	Initial issue	September 2007

PROPRIETARY NOTICE

All data and information contained within this manual is of a proprietary nature with the exclusive title to the same held by Baldwin Boxall Communications Limited. The possession of this manual and the use of the information is, therefore, restricted only to those persons duly authorised by Baldwin Boxall Communications Limited.

Do not reproduce, transcribe, store in a retrieval system or translate into any language, any part of this manual without the prior permission of Baldwin Boxall Communications Limited.

In the interest of continual product development, Baldwin Boxall Communications Limited reserves the right to make changes to product specification without notice or liability. Use of Baldwin Boxall Communications Limited products as critical components in life support systems is not authorised except with express written approval from Baldwin Boxall Communications Limited.

SAFETY INFORMATION

Personnel who install, maintain or repair this equipment must read the safety information below before starting work.

Voltages in excess of 30 Volts RMS or 50 Volts DC are considered Hazardous and in certain circumstances can be lethal.

If Functional Testing, Maintenance, or Repair is to be completed with the Mains Power (and/or battery backup) connected then this should only be undertaken by personnel who are fully aware of the danger involved and who have taken adequate precautions and training.

This Manual contains Warnings, Cautions and Notes.

Warnings describe potential threats to health or life, e.g.



WARNING

Before attempting to remove this component, ensure the Mains Power Supply and Battery Backup have been disconnected.

Cautions describe potential threats to the equipment, e.g.



CAUTION

Notice must be taken of all cautions.
If a Caution is ignored the equipment may be damaged.



CAUTION: ELECTRO-STATIC SENSITIVE DEVICES

Observe the relevant precautions for the protection of Electro-static Sensitive Devices when handling this equipment.

Notes are statements that are useful to the user in the context of a particular section of the manual, e.g.



NOTE: Do not speak into the microphone until the "Speak Now" LED is illuminated.

COMMENTS

Comments regarding the content of this manual are welcome and should be addressed to mail@baldwinboxall.co.uk.

I Introduction

I.1 BVRD2M TECHNICAL DESCRIPTION

The VIGIL EVAS BVRD2M is a DSP controlled Voice Alarm Routing Matrix that is fully compliant with BS5839 part 8 and EN60849.

The BVRD2M master unit provides eight electronically balanced inputs, each with 3 band parametric (plus bass and treble) equalisation, an optional limiter / compressor, and independent priority settings.

Inputs 1 and 2 are normally reserved for fire microphones and are configurable with an “All Call” processor bypass.

There are seven electronically balanced outputs, each with 10 band parametric EQ and selectable audio delay of up to 1 second.

Up to six CD quality messages, each of a maximum of 57 seconds, can be stored in DSP memory. Each message has independent level, surveillance and timing settings.

There is also a single “All Call” fail safe EPROM message generator that can be used in the unlikely event of processor failure.

The unit is fully monitored and includes a real time clock that is used for date stamping the stored fault / event log.

I.2 FRONT PANEL CONTROLS & SETTINGS

Figure I.1 — BVRD2M Front Panel

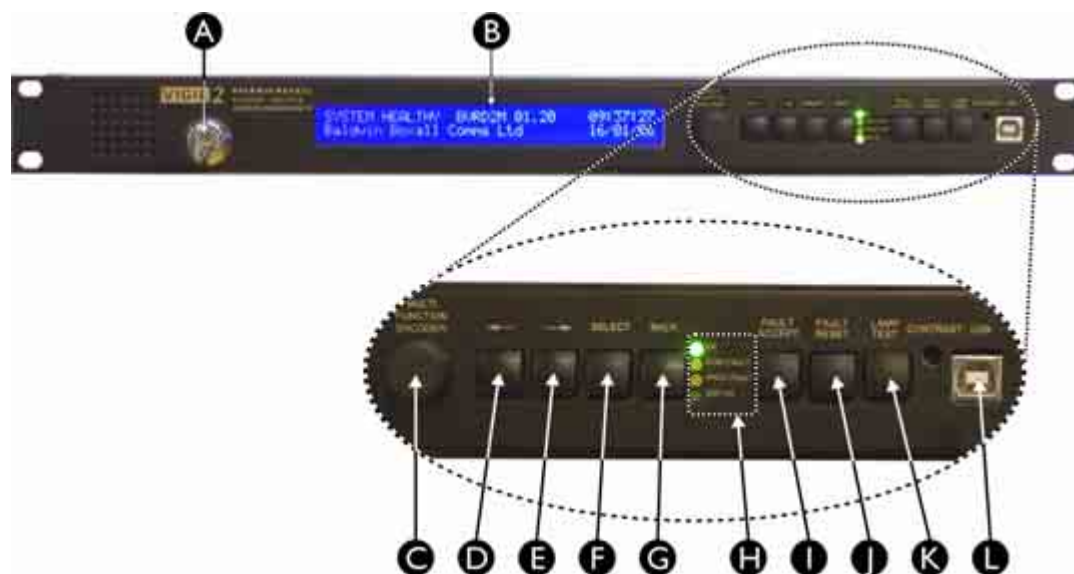

A	Access Control / System Configuration Key Switch	Unless Key is turned (and password entered), access to configuration options is not available to prevent unauthorised or accidental changes to system setup
B	40 x 2 Character LCD Display	Shows either the current system status, or, if in Configuration mode the options and menus available
C	Multi Function Encoder	Used for changing values and entering text when in Configuration Mode
D	Left "←" navigation button	Press to move left through available menus and options
E	Right "→" navigation button	Press to move right through available menus and options
F	"Select" navigation button	Press to choose the currently selected option
G	"Back" navigation button	Press to move back to the previous menu
H	Status LEDs	"OK" - No faults detected "Com Fault" - Fault detected, shown on LCD Display "Proc Fault" - Processor or Internal Comms fault detected. Potentially Fail Safe operation only available (hard wired All Call on Mic 1 & 2 and EM message will operate correctly). "DSP OK" - flashes to indicate DSP has no faults
I	"Fault Accept" button	Press to accept a fault and silence the buzzer
J	"Fault Reset" button	Press to reset a displayed fault (Note: only available if key switch is turned)
K	"Lamp Test" button	Press to check LEDs and sounder
L	USB port connection	Connection for Configuration Software

I.3 REAR PANEL CONNECTIONS

Figure I.2 — BVRD2M Rear Panel

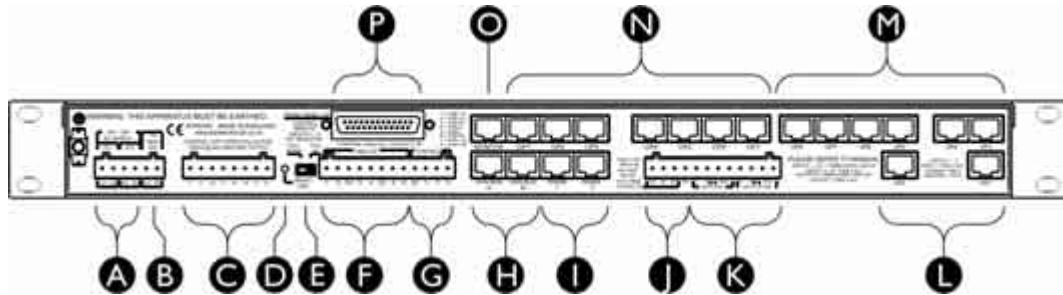

A	Dual 24V PSU Inputs	The BVRD2M requires two separate 24V DC supplies. A fault will be announced if either of the supplies is not connected.
B	Aux 24V Output	Auxillary 24V supply derived from both PSU inputs. Max output 1A.
C	Open Collector Control Outputs	6 x NPN collector outputs (max 40V @ 100mA) for busy etc
D	Reset DSP Button	Initiates a Processor / Firmware restart
E	Analogue Inputs 1-4 Pull Down Switch	Analogue inputs 1-4 are usually pulled high (18V). When used for ANS, the inputs must be pulled low.
F	Analogue Voltage Sensing Control Inputs	6 x analogue voltage sensing inputs for monitored input access, ambient noise sensors, remote volume controls, etc.
G	Simple Contact Closure Control Inputs	3 x contact closure inputs for unmonitored input access etc.
H	CAN BUS Connections	2 x CAN BUS ports to enable additional Modules to be connected. Refer to section I.6 for details of these modules.
I	RS485 Port Connections	2 x RS485 half duplex ports for communicating to control microphones, fire detection systems, network control, fault reporting etc.
J	Common Fault Output Relay Contacts	1 x volt free relay changeover contact for Common Fault
K	Optocoupled Control Inputs from Fire Detection System	2 x opto coupled sounder circuit inputs: EM input "All Evacuate" has processor bypass option, I/PI is programmable
L	Audio Inputs 1 & 2	Electronically balanced line -20dB audio inputs. Normally reserved for Fire Microphones as both inputs have processor bypass option.
M	Audio Inputs 3 - 8	Electronically balanced line -20dB audio inputs.
N	Audio Outputs 1 - 7	Electronically balanced line 0dB audio outputs
O	Monitor Output	Not normally used
P	Auxillary Front Panel Output	Feature not implemented.

I.4 BVRD2M SPECIFICATIONS

I.4.1 Audio Input Specifications

Input Sensitivity	80mV (-20dB) to 3V (+12dB)
Frequency Response	-3dB @ 30Hz and 20KHz
Signal to Noise Ratio	Better than 70dB
Phantom Power	12V
3 Band Parametric Equalisation	
Frequency	50Hz, 63Hz, 80Hz, 100Hz, 125Hz, 160Hz, 200Hz, 250Hz, 315Hz, 400Hz, 500Hz, 630Hz, 800Hz, 1KHz, 1.25KHz, 1.6KHz, 2KHz, 2.5KHz, 3.15KHz, 4KHz, 5KHz, 6.3KHz, 8KHz, 10KHz, 12.5KHz, 16KHz
Band width	0.05 oct, 0.1 oct, 0.2 oct, 0.33 oct, 0.5 oct, 0.66 oct, 1 oct, 2 oct
Lift and Cut	±12dB in 1dB steps
Low Filter	
Frequency	250Hz, 315Hz, 400Hz, 500Hz, 630Hz, 800Hz, 1KHz, 1.2KHz, 1.6KHz, 2KHz, 2.5KHz
Slope	3dB/oct and 6dB/oct
Lift and Cut	±12dB in 1dB steps
High Filter	
Frequency	500Hz, 630Hz, 800Hz, 1KHz, 1.25KHz, 1.6KHz, 2KHz, 2.5KHz, 3.15KHz, 4KHz, 5KHz
Lift and Cut	±12dB in 1dB steps
High Pass Filter	
Frequency	100Hz, 150Hz, 200Hz, 250Hz, 300Hz
Slope	18dB/oct, 12dB/oct, 6dB/oct
Compressor	
Ratio	1.4:1, 2:1, 4:1, 8:1 and limiter
Attack	0 to 99mS
Release	0 to 999mS
Fail Safe Message EPROM	
Storage Medium	EPROM (non volatile)
Maximum Message Length	20 Seconds
Frequency Response	-3dB @ 100Hz and 12KHz
Signal to Noise Ratio	Better than 60dB
Messages Flash PROM	
Storage Medium	Flash PROM (non volatile)
Maximum Message Length	57 Seconds
Frequency Response	-3dB @ 50Hz and 18KHz
Signal to Noise Ratio	Better than 65dB
Power Requirement	22V to 35V @ 500mA max

1.4.2 Audio Output Specifications

Nominal Output Level	0.775dB (0dB)
Maximum Output Level	4.5V (+15.5dB)
Frequency Response	-3dB @ 30Hz and 20KHz
Output noise ref to 0dB	Better then -85dB
10 Band Parametric Equalisation	
Frequency	50Hz, 63Hz, 80Hz, 100Hz, 125Hz, 160Hz, 200Hz, 250Hz, 315Hz, 400Hz, 500Hz, 630Hz, 800Hz, 1KHz, 1.25KHz, 1.6KHz, 2KHz, 2.5KHz, 3.15KHz, 4KHz, 5KHz, 6.3KHz, 8KHz, 10KHz, 12.5KHz, 16KHz,
Band width	0.05 oct, 0.1 oct, 0.2 oct, 0.33 oct, 0.5 oct, 0.66 oct, 1 oct, 2 oct
Lift and Cut	±12dB in 1dB steps
Low Filter	
Frequency	250Hz, 315Hz, 400Hz, 500Hz, 630Hz, 800Hz, 1KHz, 1.2KHz, 1.6KHz, 2KHz, 2.5KHz
Slope	3dB/oct and 6dB/oct
Lift and Cut	±12dB in 1dB steps
High Filter	
Frequency	500Hz, 630Hz, 800Hz, 1KHz, 1.25KHz, 1.6KHz, 2KHz, 2.5KHz, 3.15KHz, 4KHz, 5KHz
Lift and Cut	±12dB in 1dB steps
Audio Delay	Selectable from 0 to 1 second

1.4.3 Control Inputs / Outputs

Control Inputs	
Fire Panel EM	1 x opto coupled sounder circuit "All Evacuate" input from fire detection system. This input has an all call processor bypass.
Fire Panel I/P 1	1 x opto coupled sounder circuit programmable input from the fire detection system
Analogue Voltage Sensing	6 x analogue voltage sensing inputs for monitored input access, ambient noise sensors, remote volume controls, etc.
Simple Contact Closure	3 x contact closure inputs for unmonitored input access etc.
Control Outputs	
NPN Collector outputs	6 x NPN collector outputs (max 40V @ 100mA) for busy etc
Relay Contacts	1 x volt free relay changeover contact for Common Fault
Serial Ports	
RS485	2 x RS485 half duplex ports for communicating to control microphones, fire detection systems, network control, fault reporting etc.
CANBUS	1 x CANBUS port to communicate to surveillance modules etc
USB	1 x front panel mounted USB port to configure the system, fault diagnosis, fault reporting, download messages etc.

I.5 BVRD2S SLAVE UNIT

I.5.1 Main Features

Adding a BVRD2S to a BVRD2M increases the number of inputs available by 12, the number of outputs by 16 and adds another 12 messages.

Up to five slave units can be added to each master, making a maximum total of 68 inputs, 87 outputs and a maximum of 30 messages.

The slave units mount directly on top the master unit. To minimise rack wiring, the power and communications between master and slave units are through an internal data link.

For installations that do not require the full range of additional inputs, outputs or messages, a “Half” slave is available that provides 6 inputs, 8 outputs and 6 messages.

I.5.2 Rear Panel Connections

Figure 1.3 — BVRD2S Rear Panel

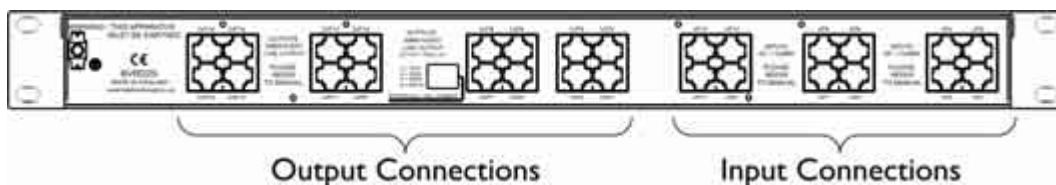

All connections are made to the BVRD2S using RJ45 connectors.

The “Bypass All Call Enable” switch can be used to prevent an “All Call” message from being broadcast to the selected outputs.

This is often required if one of the outputs is being used as a local monitor.

I.6 BVRD2M CANBUS MODULES

There are currently three CANBUS modules available providing the following main features:

I.6.1 BVRDACO

- 10 x BEL line surveillance with earth leakage fault detection
- 11 x amplifier surveillance, 10 with auto change over
- 1 x RS485 half duplex ports for communicating to control microphones, fire detection systems, network control, fault reporting etc.

I.6.2 BVRDFPI

- 24 x opto coupled inputs from fire detection systems
- 1 x common fault volt free change over relay contacts
- 1 x RS485 half duplex ports for communicating to control microphones, fire detection systems, network control, fault reporting etc.

I.6.3 BVRDCI

- 16 x analogue voltage sensing inputs for monitored and unmonitored input access, ambient noise sensors, remote volume controls etc.
- 4 x volt free change over relay contacts for busy etc.
- 4 x NPN open collector outputs (max 40V @ 100mA) for busy etc.
- 1 x RS485 half duplex ports for communicating to control microphones, fire detection systems, network control, fault reporting etc.

1.7 SIMPLIFIED SCHEMATIC DIAGRAMS

1.7.1 BVRD2M & BVRD2S Schematic Diagrams

Figure 1.4 — BVRD2M Schematic Diagram

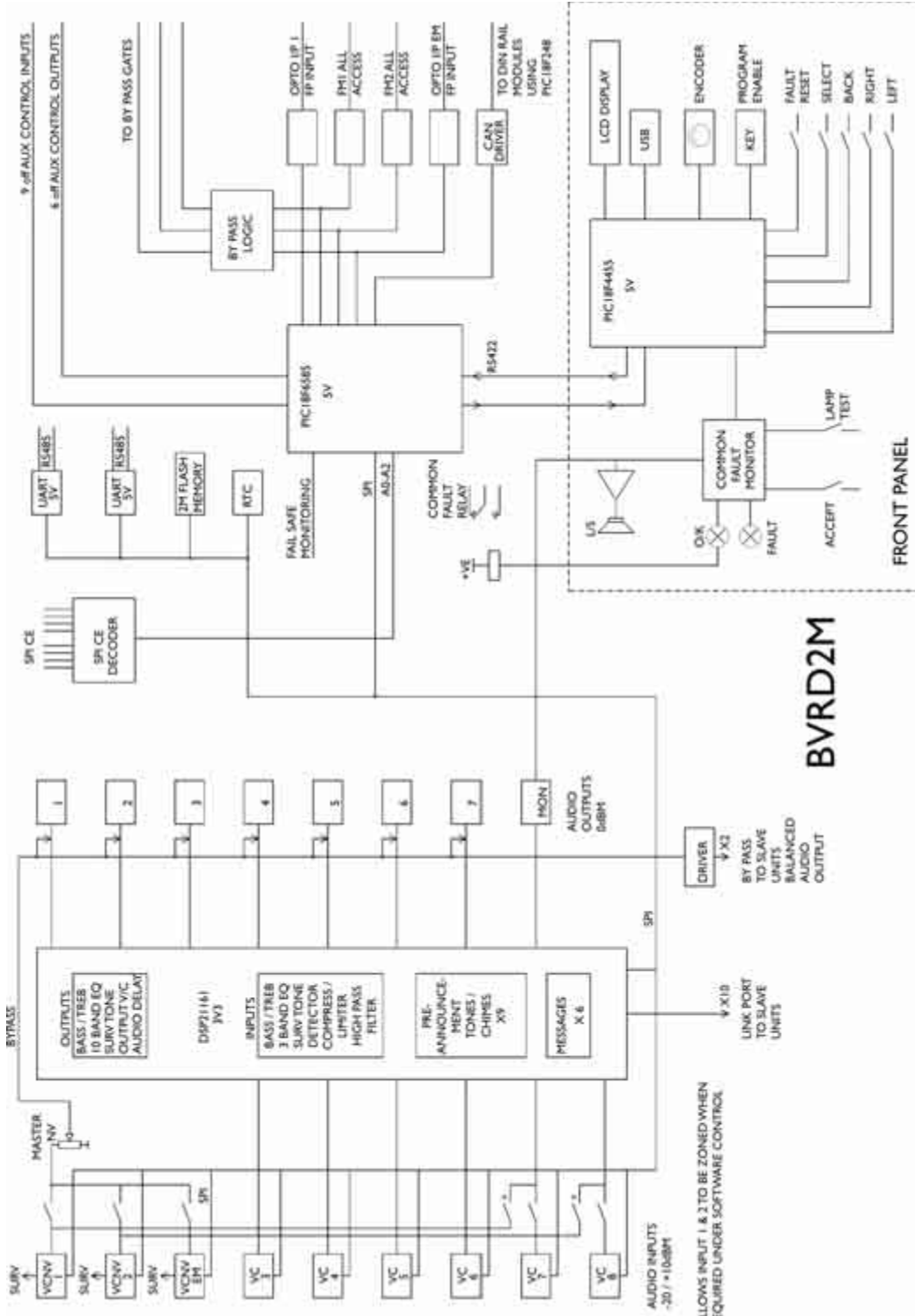
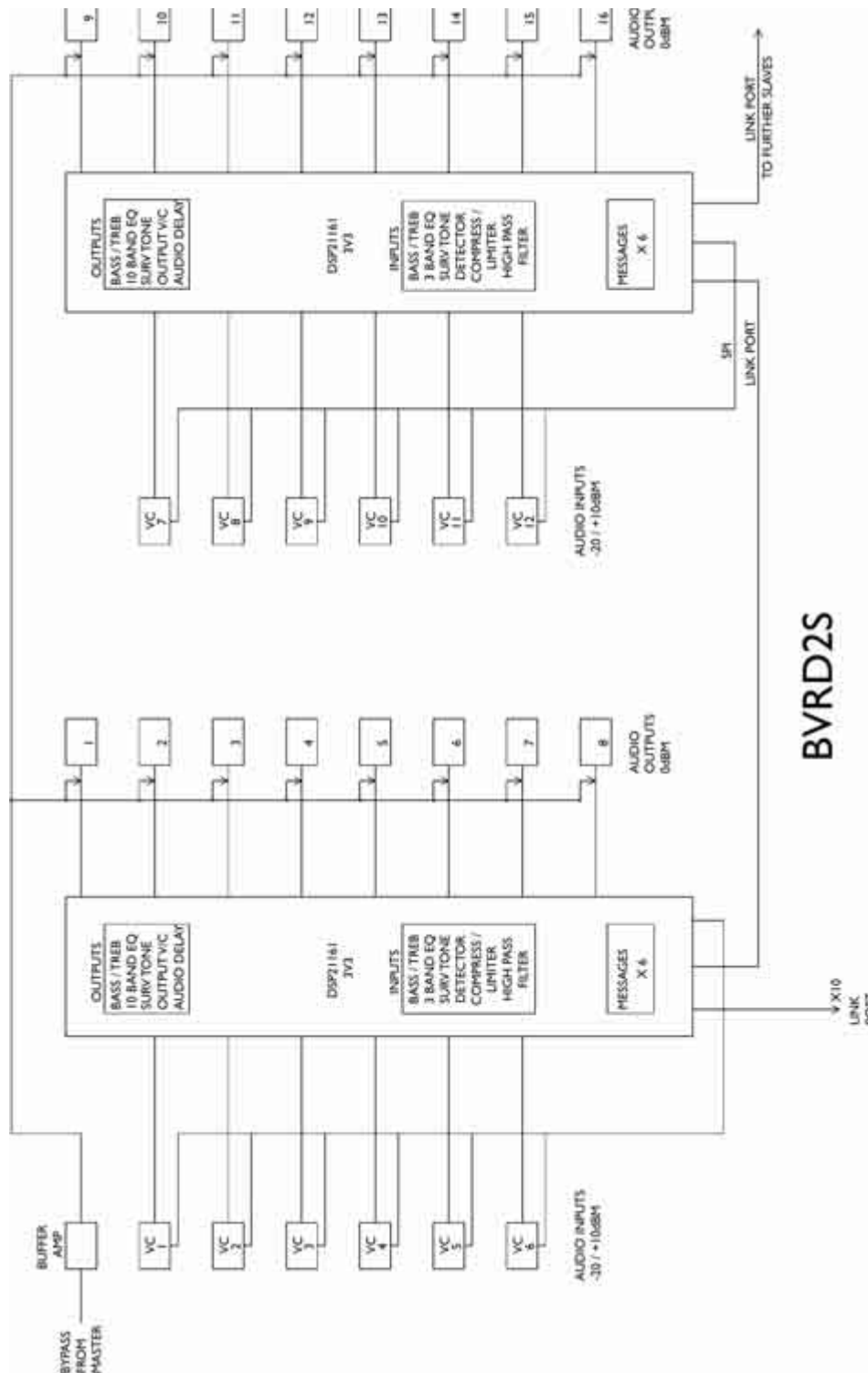

Figure 1.5 — BVRD2S Schematic Diagram



1.7.2 CAN BUS Module Schematic Diagrams

Figure 1.6 — BVRDACO Loudspeaker Line Monitor

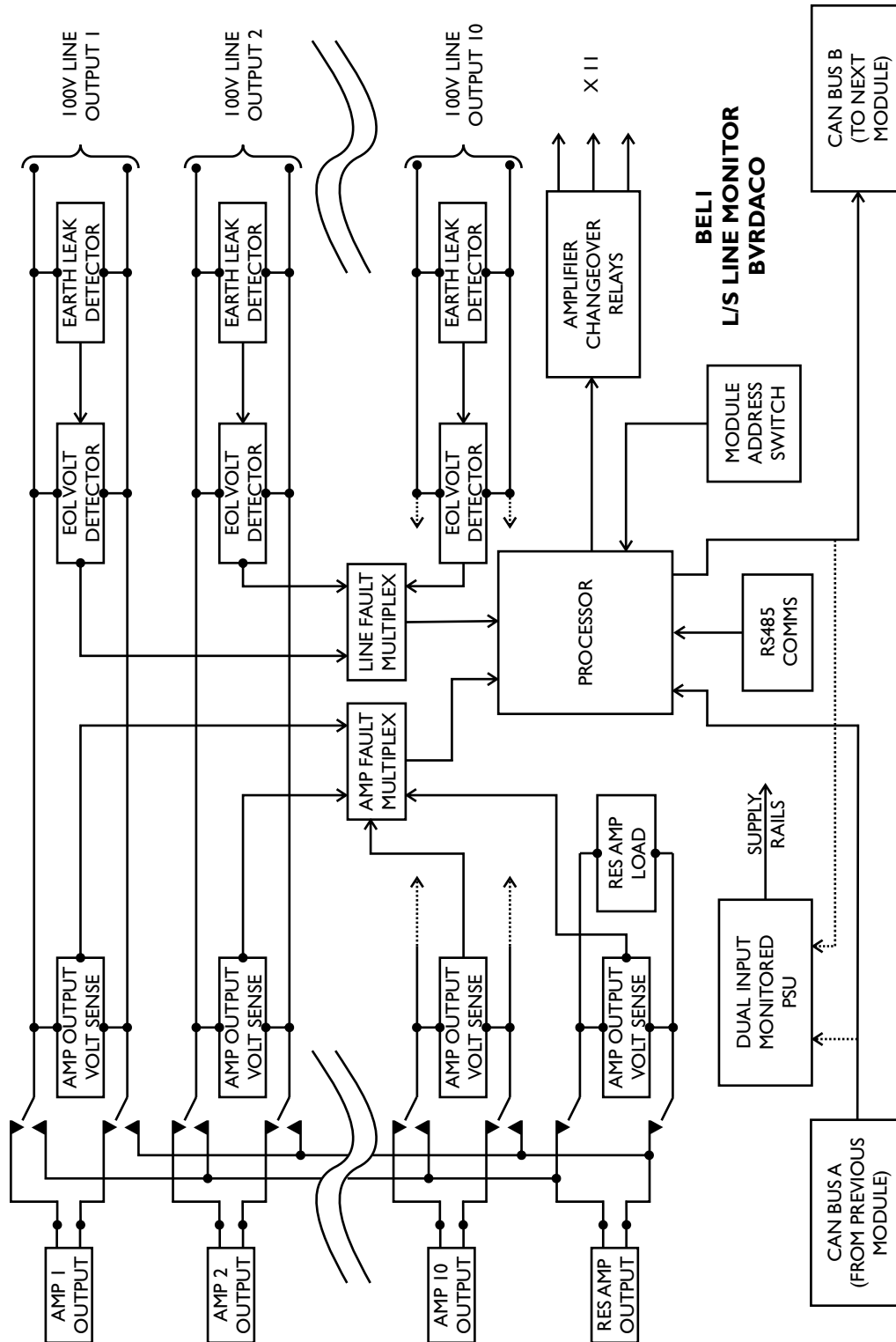

Figure 1.7 — BVRDACO Amplifier / Line Fault Detection

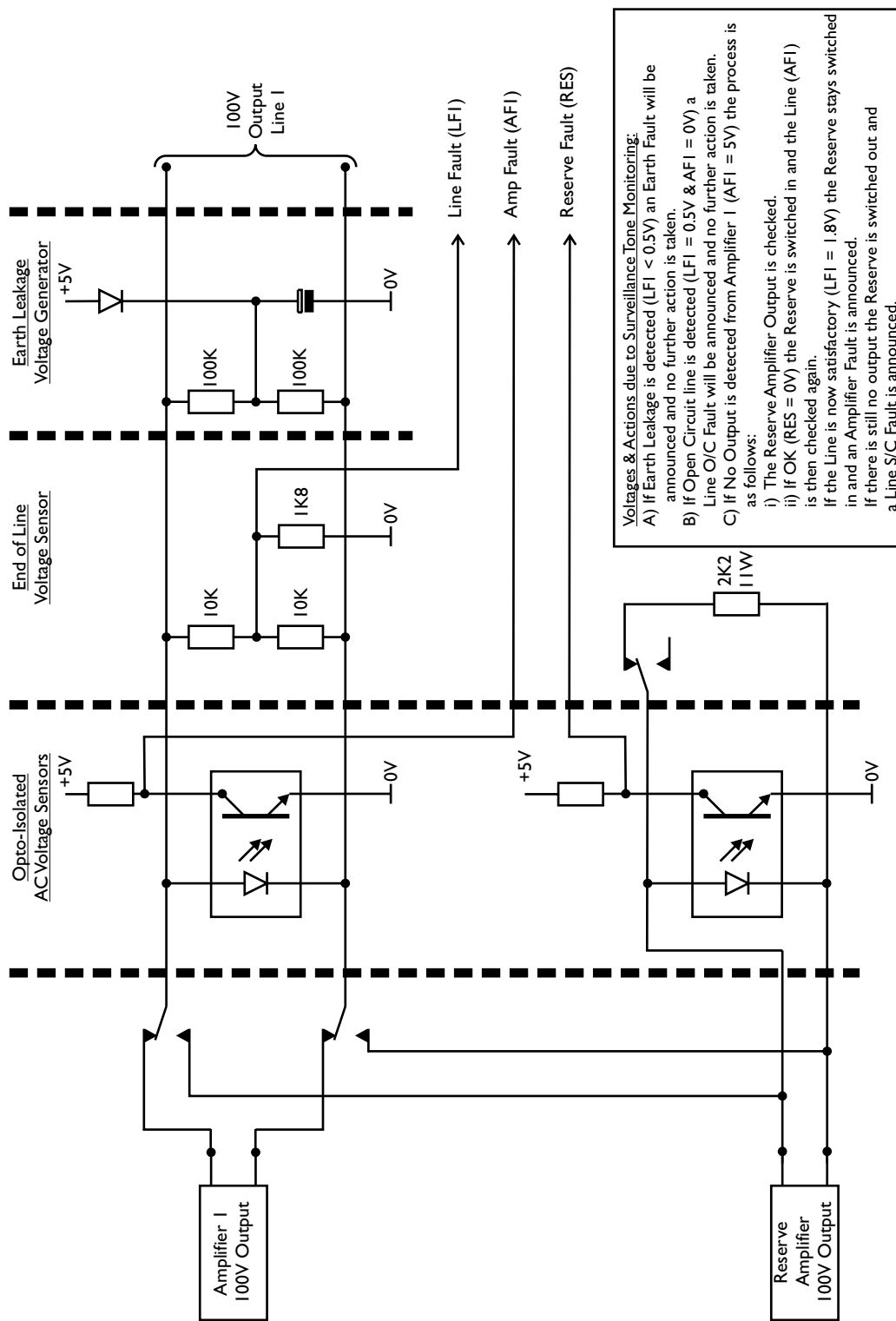

Figure 1.8 — BVRDFPI Fire Panel Interface

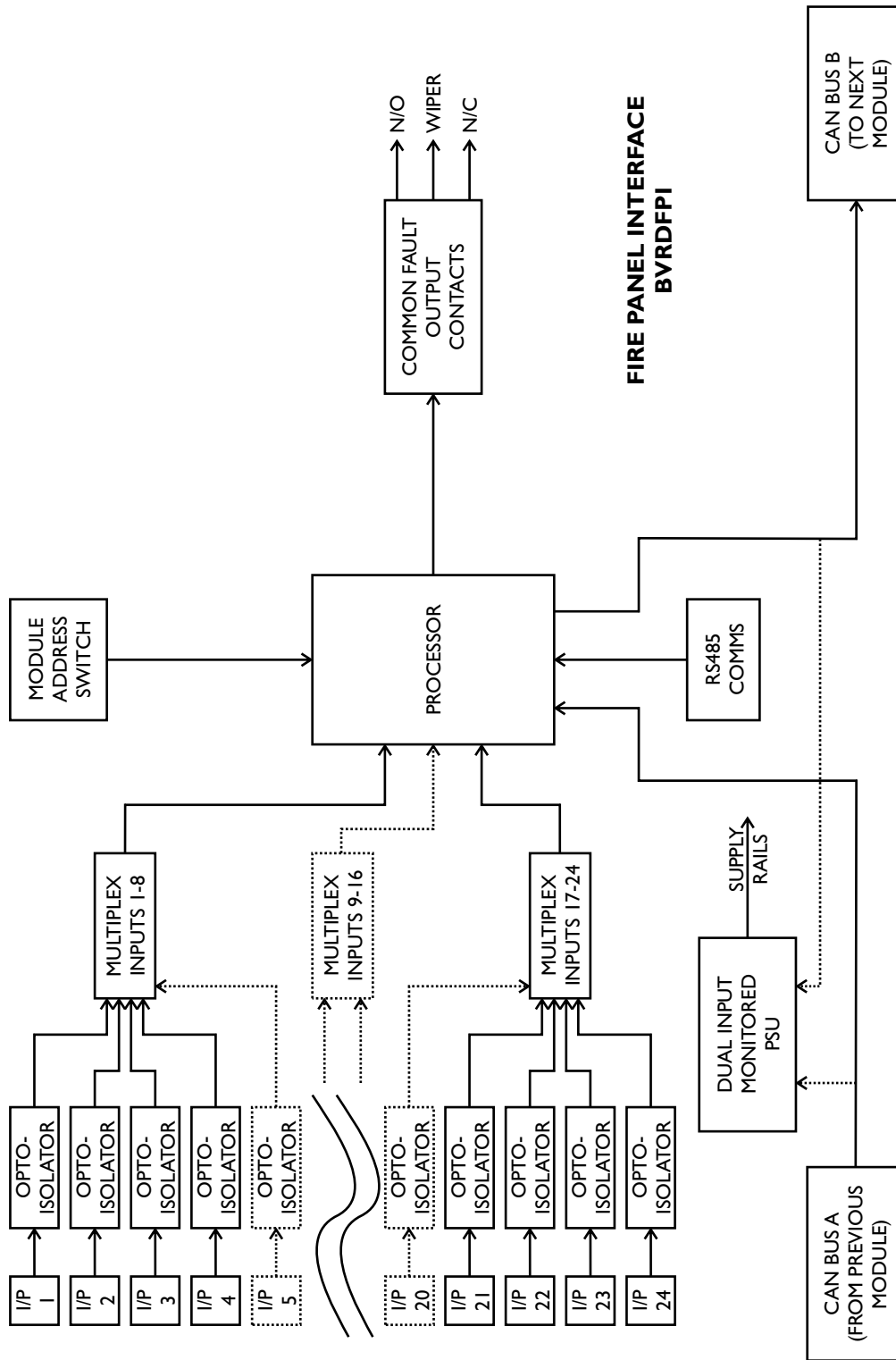
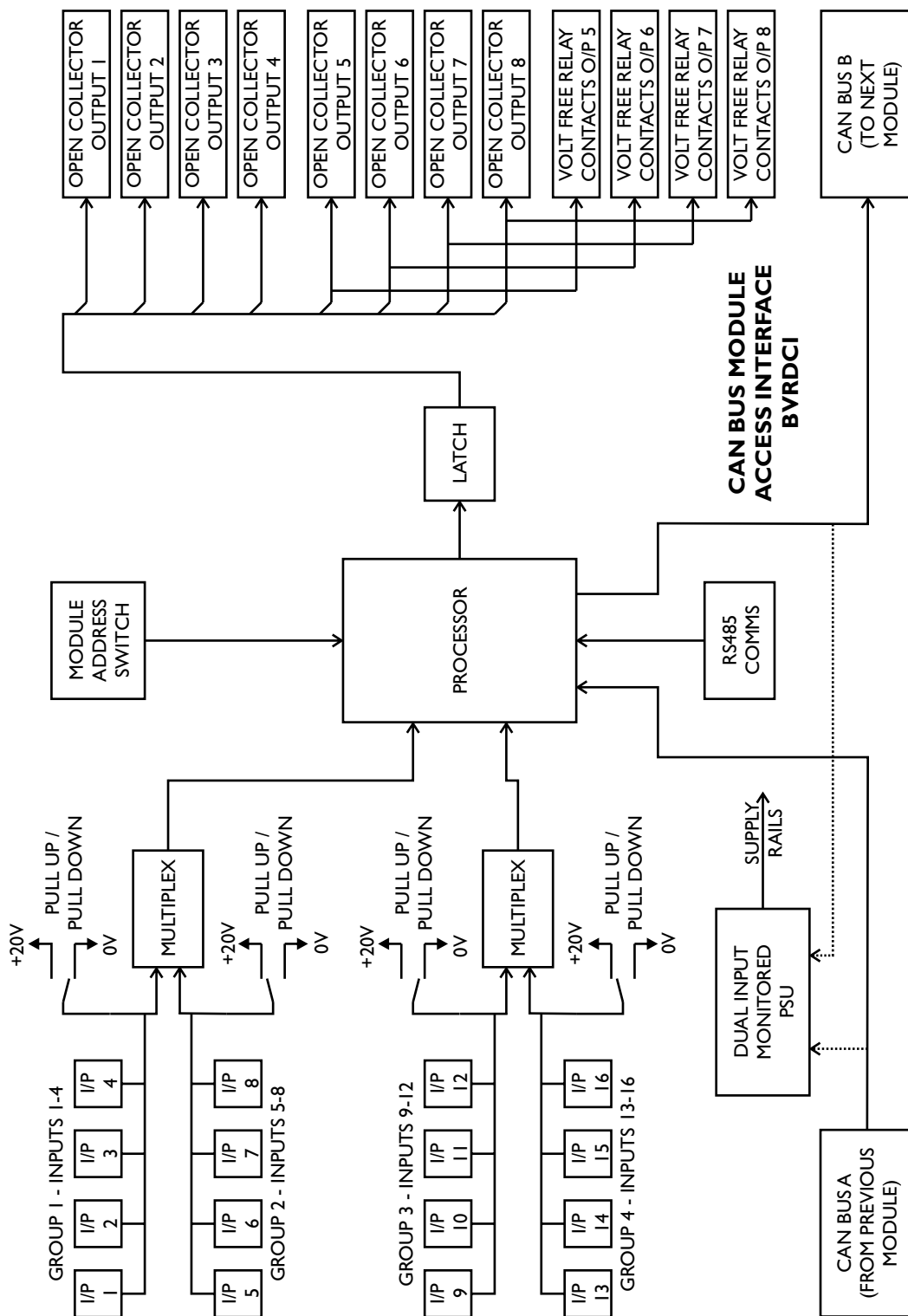

Figure 1.9 — BVRDCI Access Interface Module



1.8 TYPICAL INSTALLATION EXAMPLES

Figure 1.10 — Typical 15 Zone Single Circuit Wiring Diagram

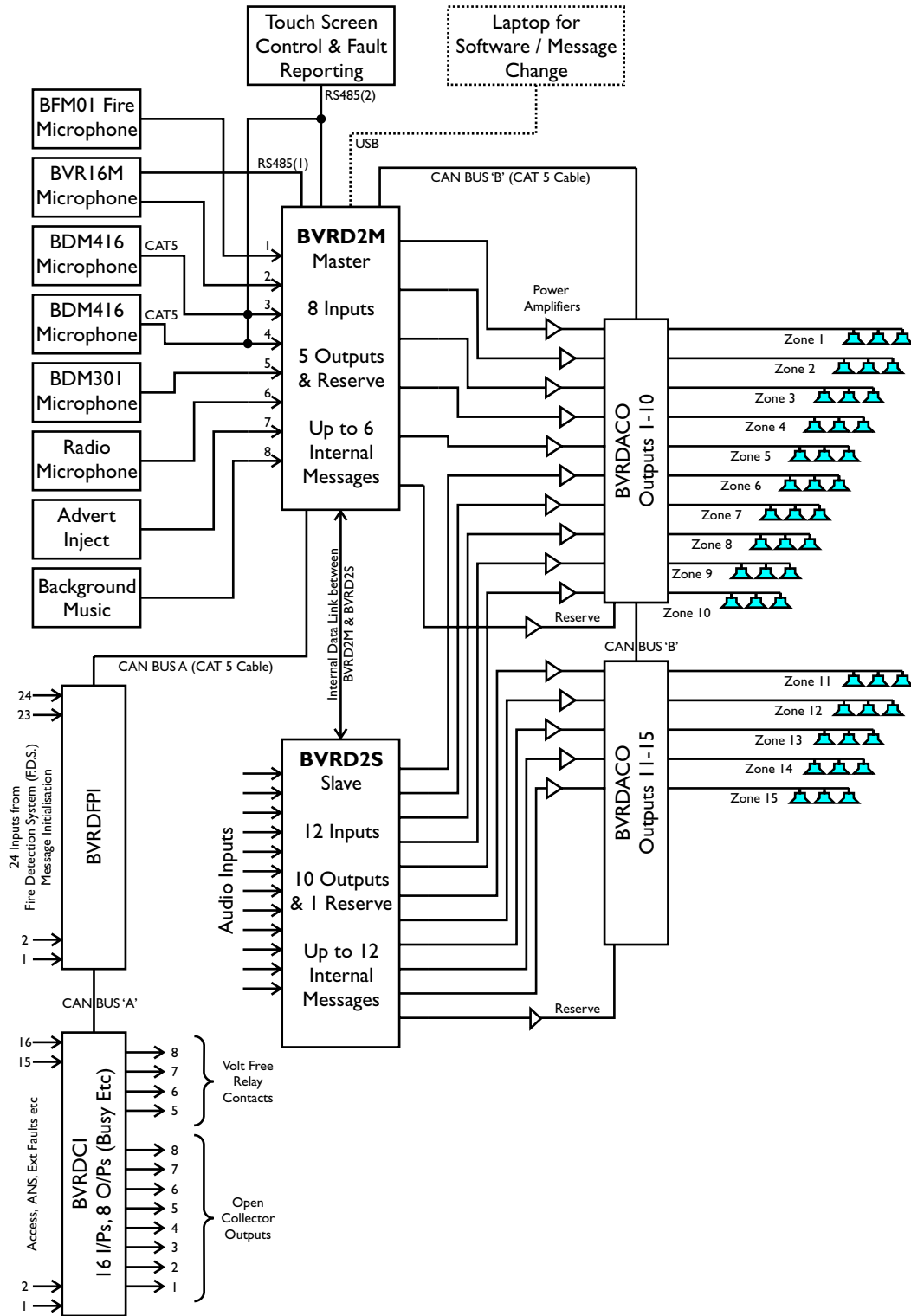
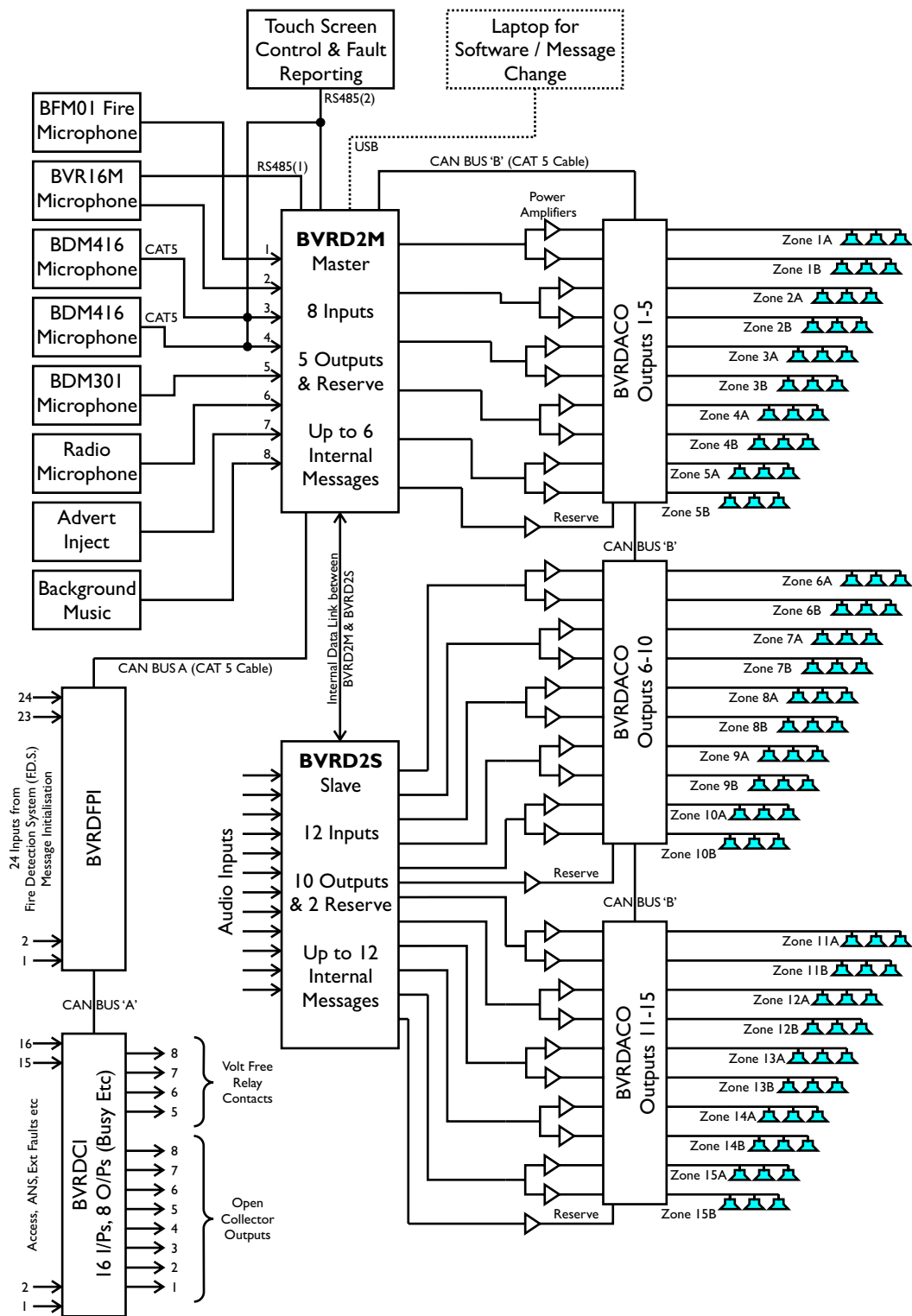

Figure 1.11 — Typical 15 Zone Dual Circuit Wiring Diagram



2 Hardware Installation

The BVRD2M and BVRD2S are both housed in 1 unit 19" Rack Mount chassis.



CAUTION

It is important that slide rails or rack runners are used to support the weight of the unit(s) when installed.

2.1 ATTACHING SLAVE UNIT(S)

The BVRD2S slave unit(s) mount directly on top the master unit.

To minimise rack wiring, the power and communications between master and slave units are via an internal data link.

Figure 2.1 — Data Link Connectors

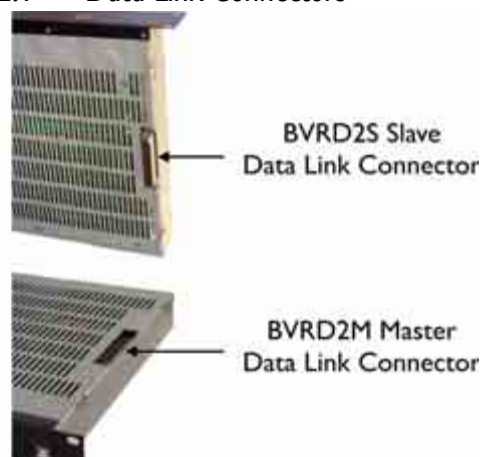

To attach a Slave unit:

- First, remove the dust covers from the data link connectors on the Master and Slave units.
- Place the Slave unit on top of the Master unit as shown in Figure 2.2.

Figure 2.2 — Slave on top of Master unit



- Carefully line up the data link connectors and gently push the two units together.
- Once fitted together, fit the four securing screws supplied through the tabs in the slave unit as shown in Figure 2.3.

Figure 2.3 — Securing Slave to Master Unit



- Repeat the above procedure if further Slave units are to be added.
- Once completed, the Master and Slave units are ready to be fitted in the Rack or Enclosure.

3 Operating Instructions

3.1 INTRODUCTION

The VIGIL EVAS BVRD2M is primarily configured using the 40 x 2 character LCD front panel display and the navigation controls as shown in Figure 3.1.

The amount of information that can be displayed at any one time is limited by the size of display, therefore a comprehensive Menu Structure is used that (depending on the Access Level) allows access to all configurable options.

The front panel controls are used to navigate through the Menu options, and also to edit text if required (e.g. Input and Output names etc).

A Keyswitch is fitted to the front panel that prevents any unauthorised or accidental changes to system configuration.

There are also a range of Access Levels that limit the changes that can be made once the key has been turned.

3.2 FRONT PANEL NAVIGATION CONTROLS

Figure 3.1 — BVRD2M Front Panel

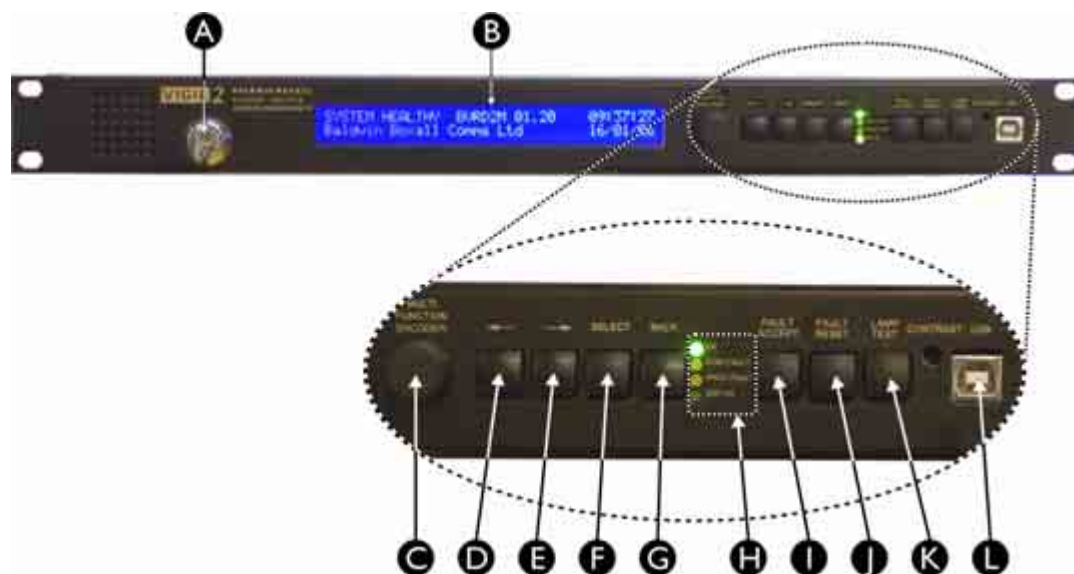

A	Access Control / System Configuration Key Switch	Unless Key is turned (and password entered), access to configuration options is not available to prevent unauthorised or accidental changes to system setup
B	40 x 2 Character LCD Display	Shows either the current system status, or, if in Configuration mode the options and menus available
C	Multi Function Encoder	Used for changing values and entering text when in Configuration Mode
D	Left "←" navigation button	Press to move left through available menus and options
E	Right "→" navigation button	Press to move right through available menus and options
F	"Select" navigation button	Press to choose the currently selected option
G	"Back" navigation button	Press to move back to the previous menu
H	Status LEDs	"OK" - No faults detected "Com Fault" - Fault detected, shown on LCD Display "Proc Fault" - Processor or Internal Comms fault detected. Potentially Fail Safe operation only available (hard wired All Call on Mic 1 & 2 and EM message will operate correctly). "DSP OK" - flashes to indicate DSP has no faults
I	"Fault Accept" button	Press to accept a fault and silence the buzzer
J	"Fault Reset" button	Press to reset a displayed fault (Note: only available if key switch is turned)
K	"Lamp Test" button	Press to check LEDs and sounder
L	USB port connection	Connection for Configuration Software

3.3 ACCESS LEVELS

There are five Access Levels to allow different personnel the relevant level of access to the system configuration options.

Table 3.1 illustrates the commands and options available to each Access Level.

Access Level 1 does not require the Keyswitch to be turned.

Access Level 2 requires the Keyswitch to be turned.

Access Levels 3-5 require the Keyswitch to be turned and the correct PIN number to be entered before the relevant system configuration options are available.

Table 3.1 — Commands and Options available to each Access Level

Configuration Command / Option	Access Level				
	1	2	3	4	5
View all Current Faults	✓	✓	✓	✓	✓
Lamp Test	✓	✓	✓	✓	✓
Monitor inputs and outputs via loudspeaker		✓	✓	✓	✓
Mute fault sounder		✓	✓	✓	✓
Reset faults		✓	✓	✓	✓
View event and fault log		✓	✓	✓	✓
Set date and time		✓	✓	✓	✓
Tests		✓	✓	✓	✓
View, but not change all other settings		✓	✓	✓	✓
Set limiter/compressor			✓	✓	✓
Set chime			✓	✓	✓
Set ANS			✓	✓	✓
Set audio output delay			✓	✓	✓
Set fade			✓	✓	✓
Set equalisation of inputs/outputs			✓	✓	✓
Set volume levels of inputs/outputs			✓	✓	✓
Set surveillance and bypass volumes				✓	✓
Configure system				✓	✓
Download messages				✓	✓
Download operating system					✓
Clear event log					✓
Change PINs for levels 3, 4 & 5					✓

3.4 NAVIGATING THE MENU STRUCTURE AND SETTING PARAMETERS

The "Multi Function Encoder", "Left", "Right", "Select" and "Back" buttons (as shown in Figure 3.1) are used to navigate through the menu structure.

There are two conventions used throughout the menu to indicate A) an adjustable parameter, B) an available sub-menu.

Figure 3.2 — Cursor Operation

A) When the cursor underlines a character it indicates an adjustable parameter. This may be a unique identifier e.g Input 01, 02, 03... etc, or may be a configuration value e.g Atenuation -20db, -19db, -18db...

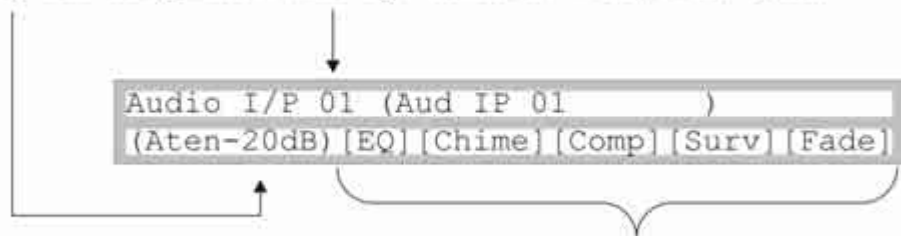

B) [Square brackets] indicate an available submenu. If active the cursor will flash on the first character.

To alter the value of a parameter, move the cursor using the "Left" and "Right" buttons until it is underlined. Rotate the Encoder until the required value / option etc is displayed.

To select a sub-menu, move the cursor using the "Left" and "Right" buttons until the first character is flashing and then press the "Select" button.

The sub-menu will then be displayed.



NOTE: Some sub-menus may not be accessible depending on the Access Level in use.

To return to the previous menu, press the "Back" button.

There are some settings (such as Audio Output) where the function can be assigned from a range of options. The currently selected function is shown by a "*" next to the relevant menu.

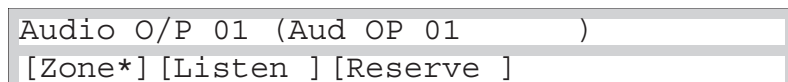

3.4.1 Illustrations of the Menu Structure

Figure 3.3 — Menu Structure - Monitor, Tests & Event Log

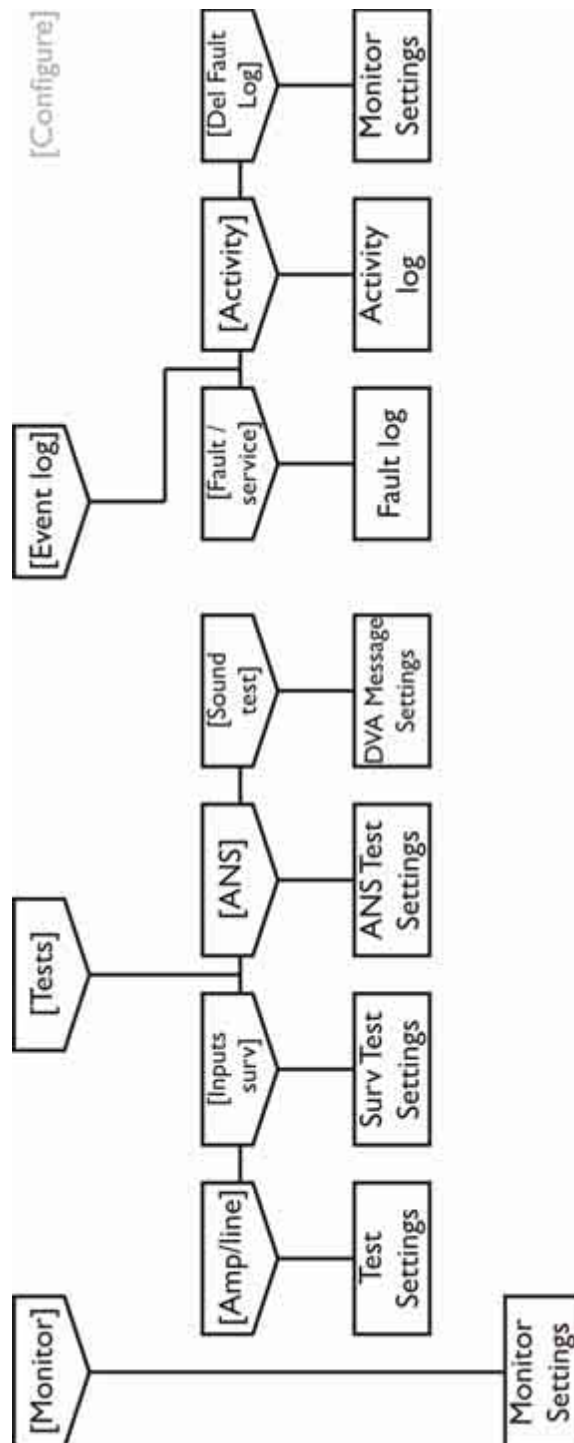

Figure 3.4 — Menu Structure - Configure - Audio - Inputs

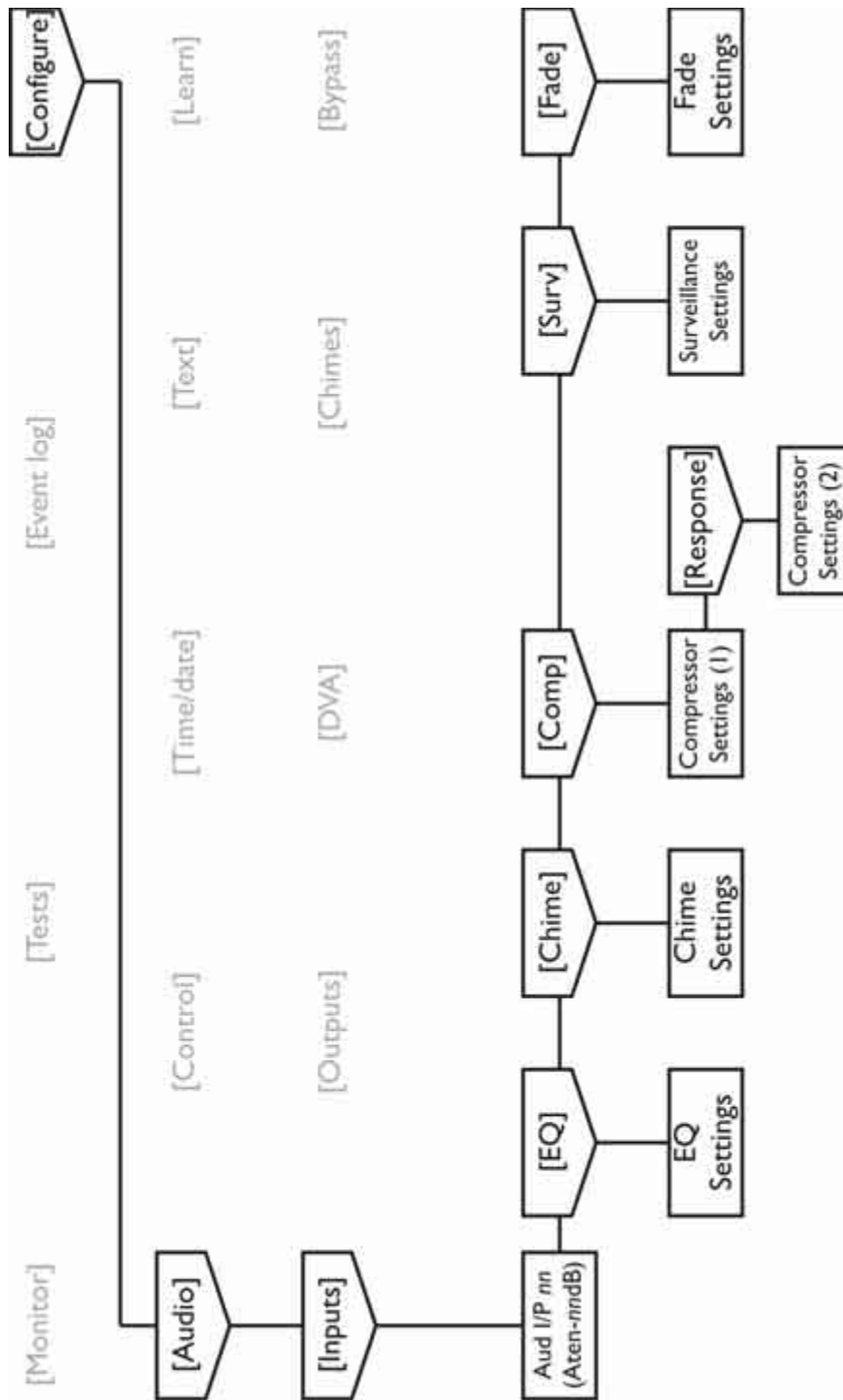
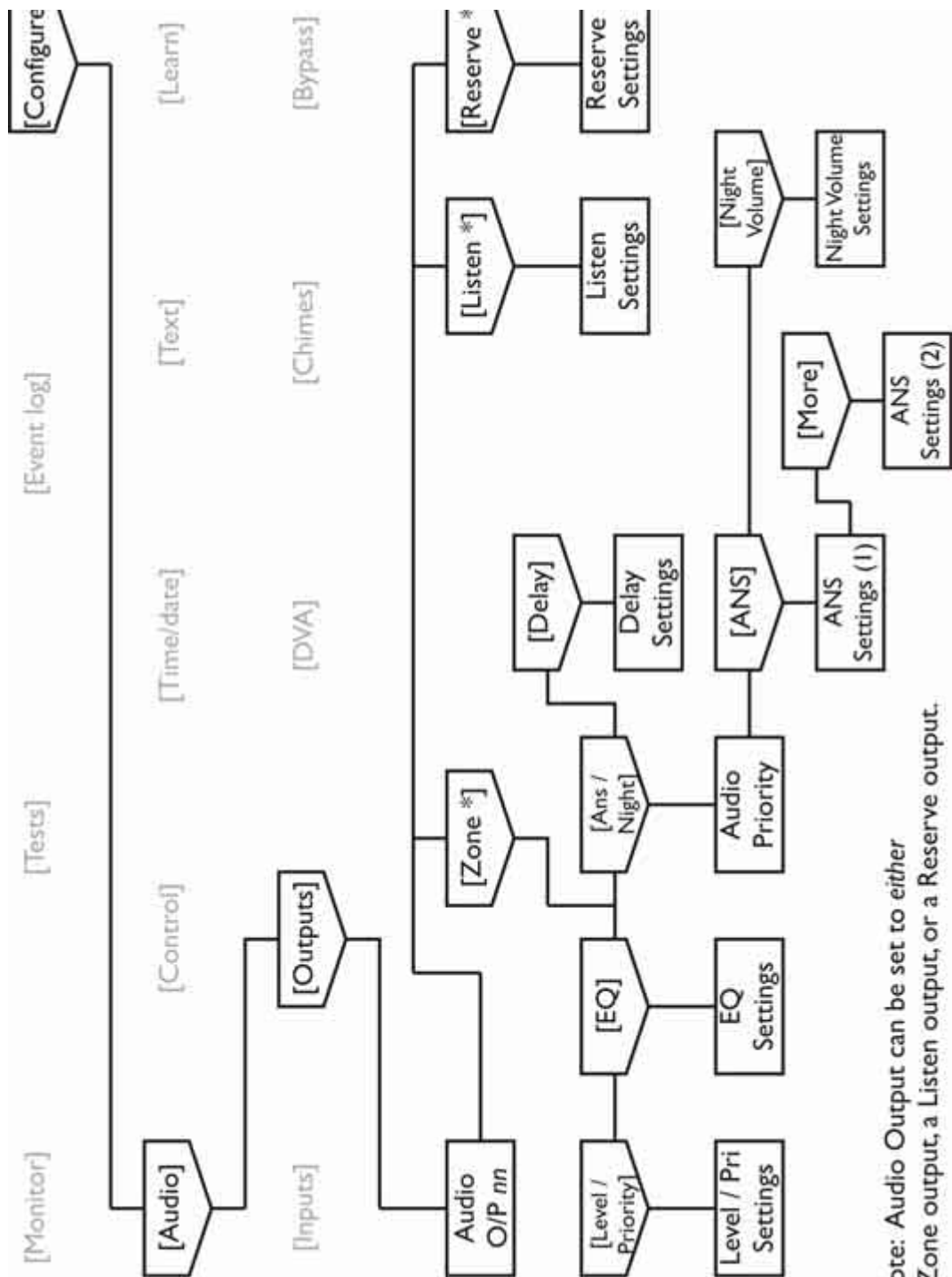

Figure 3.5 — Menu Structure - Configure - Audio - Outputs



Note: Audio Output can be set to either a Zone output, a Listen output, or a Reserve output.

Figure 3.6 — Menu Structure - Configure - Audio - DVA

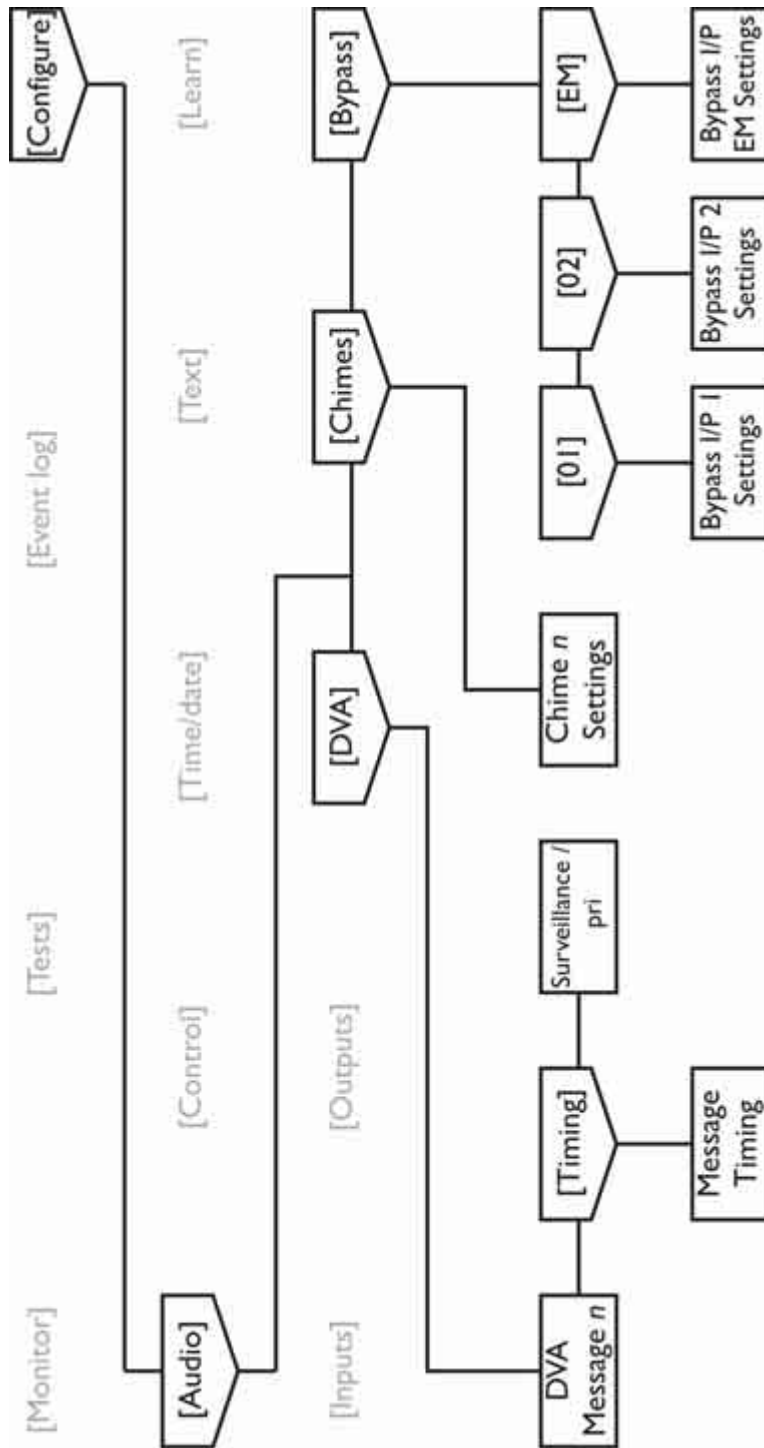

Figure 3.7 — Menu Structure - Configure - Control - Inputs

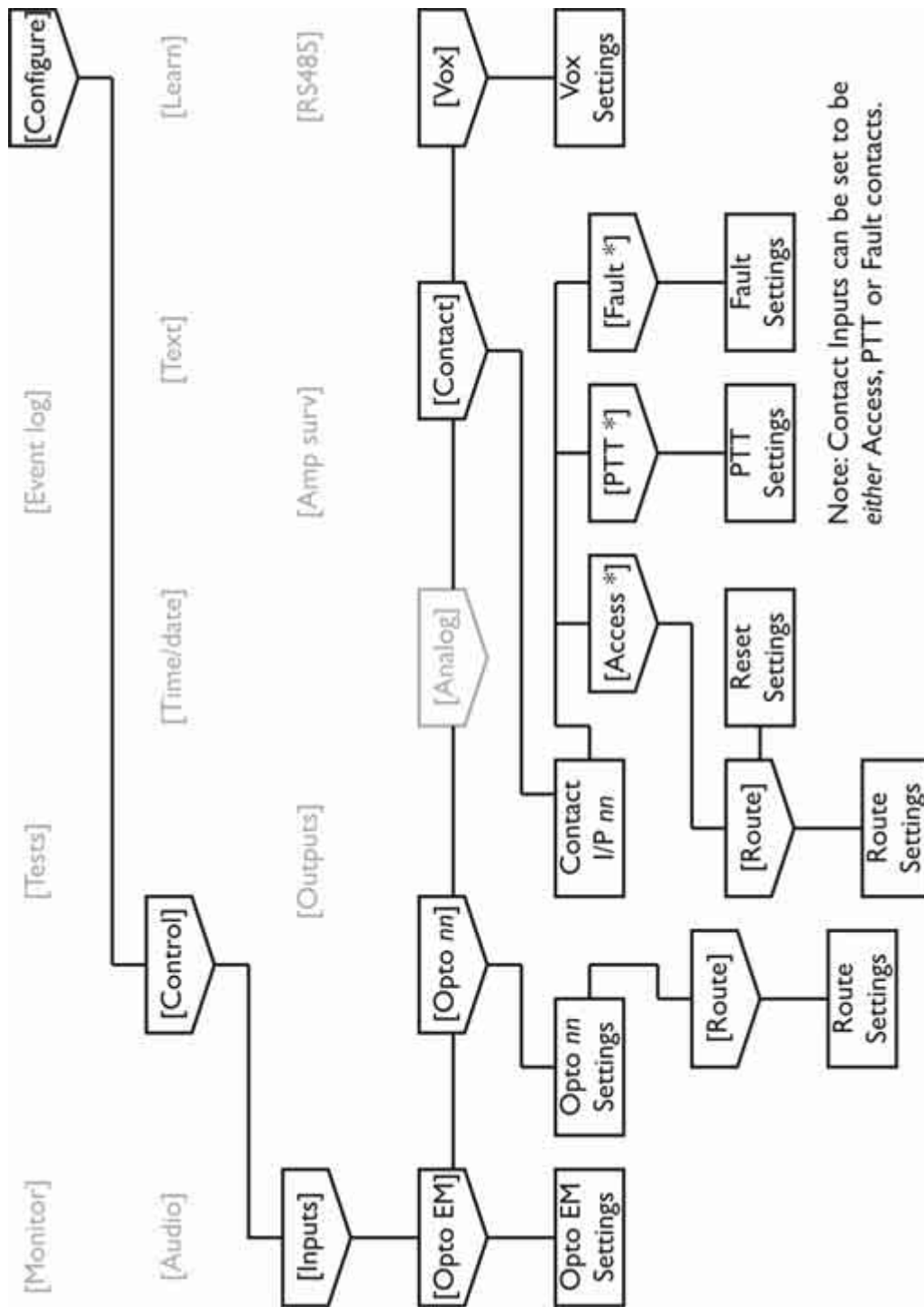

Figure 3.8 — Menu Structure - Configure - Control - Inputs (Analog)

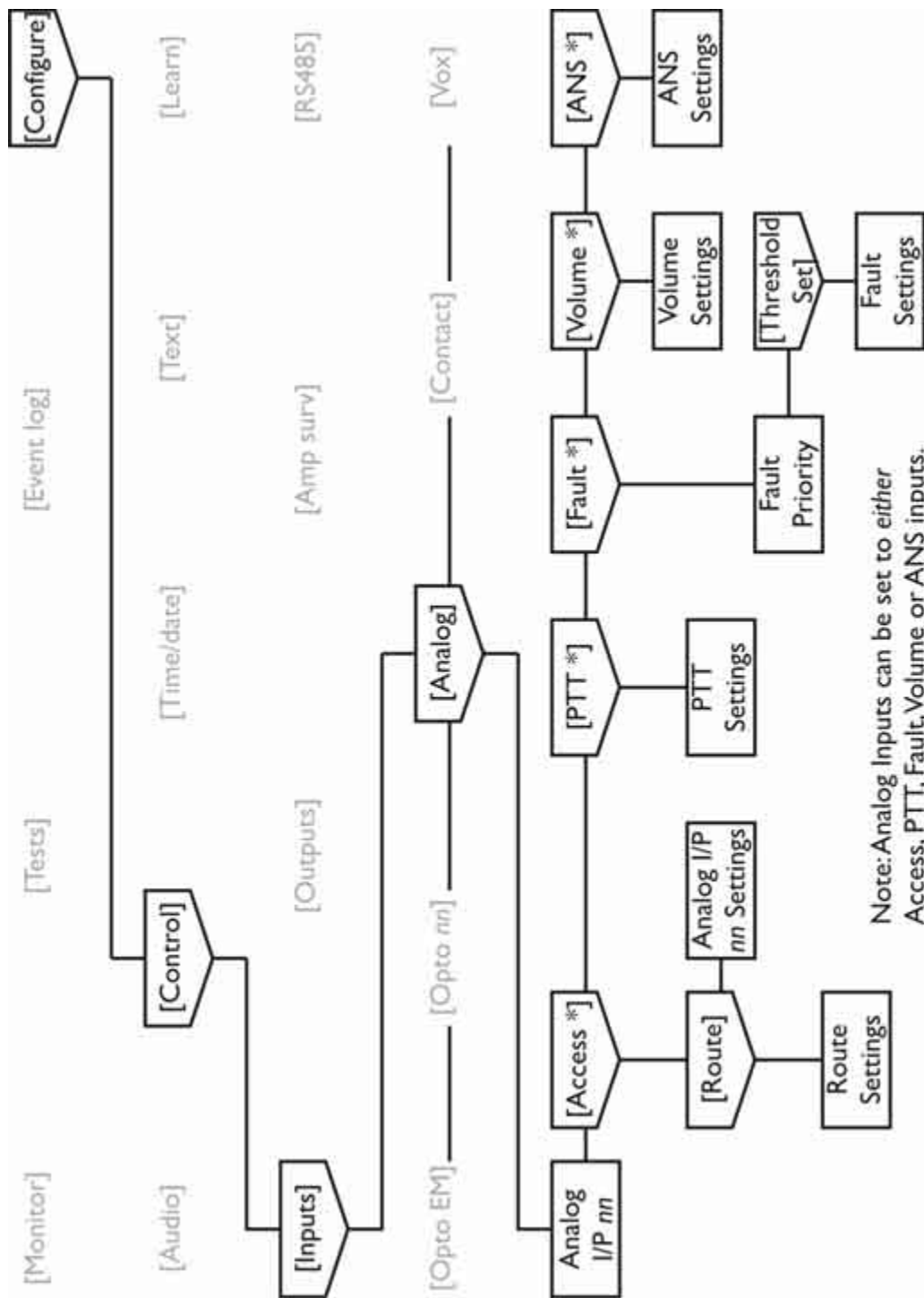

Figure 3.9 — Menu Structure - Configure - Control - Outputs & Amp Surv

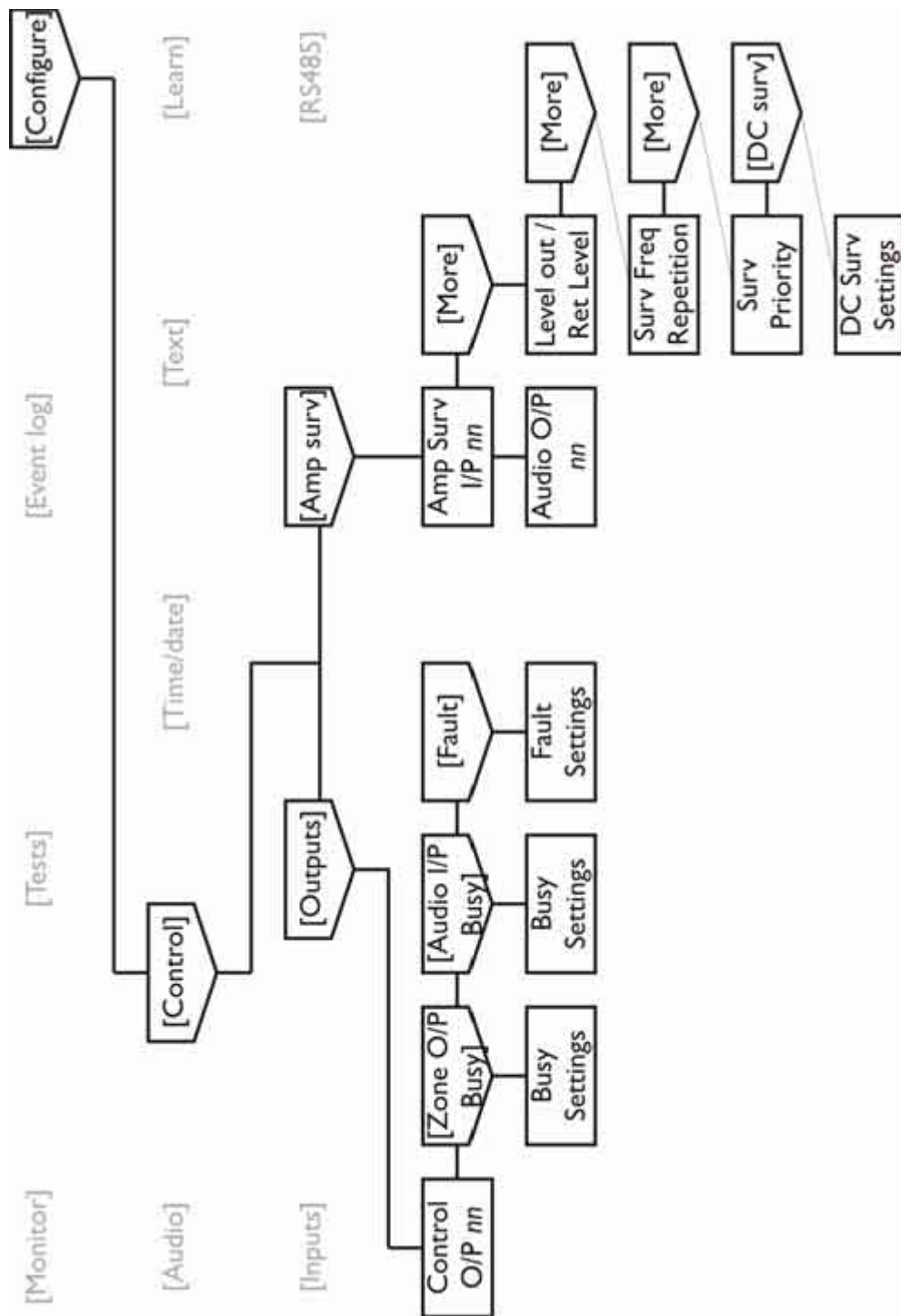
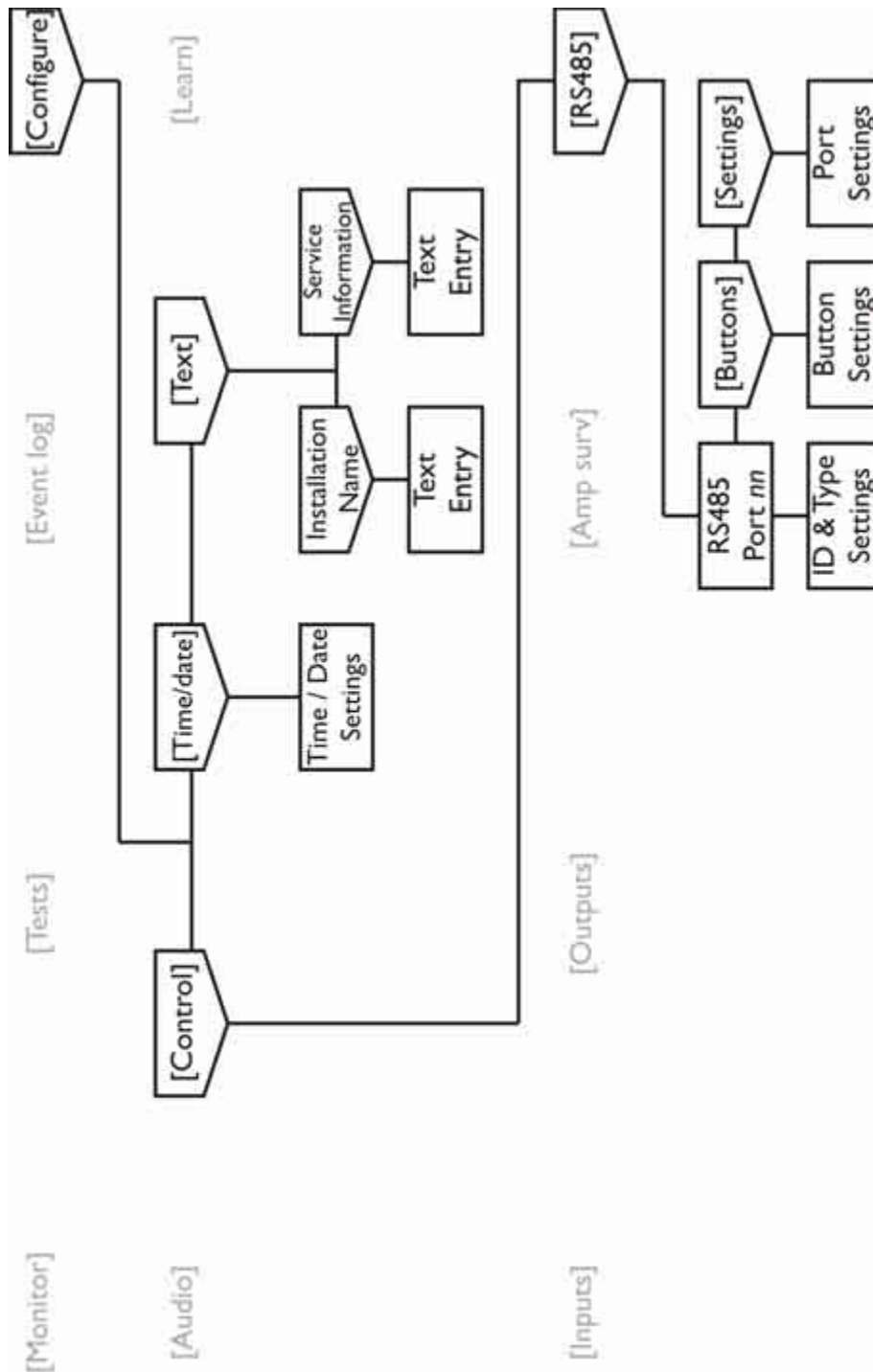

Figure 3.10 — Menu Structure - Configure - Control - RS485, Time & Text



4 System Configuration - Audio Settings

4.1 AUDIO INPUT SETTINGS

4.1.1 General Description

The BVRD2M can accommodate up to 8 audio inputs, and using BVRD2S slave units the maximum number of inputs is increased to 68.

The Audio Inputs are electronically balanced with an input sensitivity of 80mV (-20dB) to 3V (+12dB).

Each Audio Input has 3 band parametric (plus bass and treble) equalisation, and an optional limiter / compressor.

Audio Inputs 1 and 2 have a “Bypass” facility that allows them to broadcast to all zones in the unlikely event of a processor failure.

Audio Inputs 1 to 8 also have dual chime & priority settings to enable them to be used both for normal paging and for Emergency broadcasts with a different chime & priority to override DVA messages if required.

4.1.2 Audio Input Configuration

Figure 4.1 — Audio Input Menu Location

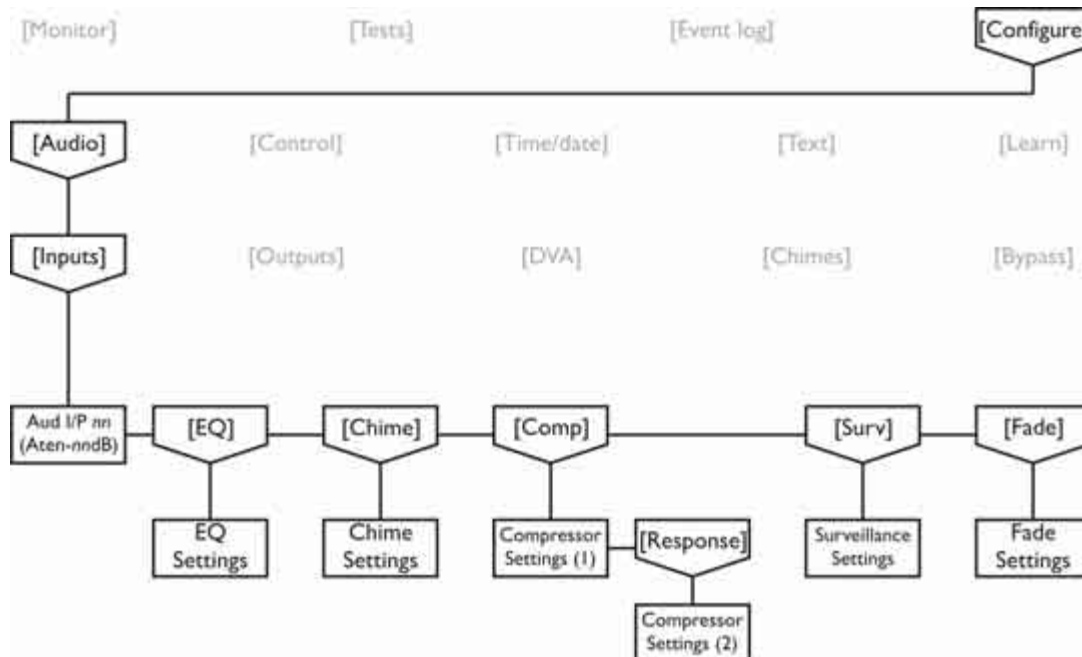

Navigate to the Audio Input menu to adjust any of the Audio Input settings.

```
Audio I/P 01 (Aud IP 01 )
[Aten-48dB] [EQ] [Chime] [Comp] [Surv] [Fade]
```

4.1.2.1 Input Attenuation setting

The Input Attenuation can be set between -48dB and 0dB.

```
Audio I/P 01 (Aud IP 01 )
[Aten-48dB] [EQ] [Chime] [Comp] [Surv] [Fade]
```

4.1.2.2 EQ Settings (including Low, High and High Pass Filters)

Select EQ from the Audio Input Menu to open the EQ menu.

```
Audio I/P 01 (Aud IP 01 )
[Aten-48dB] [EQ] [Chime] [Comp] [Surv] [Fade]
```

The available settings are shown below.

```
Audio I/P 01 (Aud IP 01 )
(Filter 01) ( 00dB) (Freq 1K00) (1/3 oct)
```

Filter 01	+12dB	Freq 50 Hz	1/10 oct
Filter 02	+11dB	Freq 63 Hz	1/5 oct
Filter 03	+10dB	Freq 80 Hz	1/3 oct
	+09dB	Freq 100 Hz	1/2 oct
	+08dB	Freq 125 Hz	2/3 oct
	+07dB	Freq 160 Hz	1 oct
	+06dB	Freq 200 Hz	2 oct
	+05dB	Freq 250 Hz	
	+04dB	Freq 315 Hz	
	+03dB	Freq 400 Hz	
	+02dB	Freq 500 Hz	
	+01dB	Freq 630 Hz	
	00dB	Freq 800 Hz	
	-01dB	Freq 1K00	
	-02dB	Freq 1K25	
	-03dB	Freq 1K60	
	-04dB	Freq 2K00	
	-05dB	Freq 2K50	
	-06dB	Freq 3K15	
	-07dB	Freq 4K00	
	-08dB	Freq 5K00	
	-09dB	Freq 6K30	
	-10dB	Freq 8K00	
	-11dB	Freq 10K00	
	-12dB	Freq 12K50	
		Freq 16K00	

Low Filter Settings

The Low filter settings are shown below.

```
Audio I/P 01 (Aud IP 01 )
(Filter LQ) ( 00dB) (Freq 1K00) (06dB/oct)
```

+12dB	Freq 250 Hz	03dB/oct
+11dB	Freq 315 Hz	
+10dB	Freq 400 Hz	
...	Freq 500 Hz	
...	Freq 630 Hz	
...	Freq 800 Hz	
...	Freq 1K00	
...	Freq 1K25	
-10dB	Freq 1K60	
-11dB	Freq 2K00	
-12dB	Freq 2K50	

High Filter Settings

The High filter settings are shown below.

```
Audio I/P 01 (Aud IP 01 )
(Filter HI) ( 00dB) (Freq 1K00) (06dB/oct)
```

+12dB	Freq 500 Hz	3dB/oct
+11dB	Freq 630 Hz	
+10dB	Freq 800 Hz	
...	Freq 1K00	
...	Freq 1K25	
...	Freq 1K60	
...	Freq 2K00	
...	Freq 2K50	
-10dB	Freq 3K15	
-11dB	Freq 4K00	
-12dB	Freq 5K00	

High Pass Filter Settings

The High Pass filter settings are shown below.

```
Audio I/P 01 (Aud IP 01 )
(Filter HP) (**dB) (Freq 200Hz) (12dB/oct)
```

Freq 160 Hz	00dB/oct
Freq 200 Hz	06dB/oct
Freq 250 Hz	12dB/oct
Freq 315 Hz	18dB/oct

4.1.2.3 Chime Settings

Select Chime to open the Chime menu.

```
Audio I/P 01 (Aud IP 01 )
[Aten-48dB] [EQ] [Chime] [Comp] [Surv] [Fade]
```

The available settings are shown below.

```
Audio I/P 01 (Aud IP 01 )
(Chime level-dB a=60 b=60) (Type a=0 b=0)
```

00dB	00dB	0	0
-01dB	-01dB	1	1
-02dB	-02dB	2	2
...	...	3	3
...	...	4	4
...	...	5	5
...	...	6	6
-58dB	-58dB	7	7
-59dB	-59dB	8	8
-60dB	-60dB	9	9

Audio inputs 1 - 8 have two independent chime type and level settings, suffix (a) and suffix (b). This allows a microphone to have a dual mode facility, one for emergency, the other for normal page.

4.1.2.4 Compressor / Limiter Settings

Select Comp to open the Compressor / Limiter menu.

```
Audio I/P 01 (Aud IP 01 )
[Aten-48dB] [EQ] [Chime] [Comp] [Surv] [Fade]
```

The available settings are shown below.

```
Audio I/P 01 (Aud IP 01 )
(OFF ) (Threshold-30dB) [Response]
```

Limiter	00dB
Comp 8:l	-01dB
Comp 4:l	-02dB
Comp 2:l	...
Comp 1.4:l	...
	...
	-28dB
	-29dB
	-30dB

Select Response to open the Response sub-menu.

The available settings are shown below.

```
Audio I/P 01 (Aud IP 01 )
(Attack 00 mSec Release 0000mSec)
```

00mS	0000mS
01mS	0005mS
02mS	0010mS
...	...
...	...
97mS	0990mS
98mS	0995mS
99mS	1000mS
Increments of 1mS	Increments of 5mS

4.1.2.5 Surveillance Level & Surveillance Priorities

Select Surv to open the Surveillance menu.

```
Audio I/P 01 (Aud IP 01 )
[Aten-48dB] [EQ] [Chime] [Comp] [Surv] [Fade]
```

The available settings are shown below.

Audio I/P 01 (Aud IP 01)		
(Audio-48dB surv/pri N) (Data surv/pri N)		
00dB	N	N
-01dB	1	1
-02dB	2	2
...	3	3
...		
-46dB		
-47dB		
-48dB		

The Audio level sets the threshold of the Surveillance tone expected on that input.

There are three Surveillance Priority settings for the Audio Surveillance. This should be set according to system requirements.

The Data Surveillance Priority can be set to check for communication faults with the relevant microphone. There are three Priority settings for this data surveillance and it should be set according to system requirements.

4.1.2.6 Fade Recovery Settings

Select Fade to open the Fade Recovery menu.

Audio I/P 01 (Aud IP 01)
[Aten-48dB] [EQ] [Chime] [Comp] [Surv] [<u>F</u> ade]

The available settings are shown below.

Audio I/P 01 (Aud IP 01)
Fade recovery time (0.0 seconds)
0.0 seconds
0.1 seconds
0.3 seconds
1.0 seconds
2.0 seconds
3.0 seconds
4.0 seconds
5.0 seconds

4.2 AUDIO OUTPUT SETTINGS

4.2.1 General Description

The BVRD2M provides up to 7 audio inputs, and using BVRD2S slave units the maximum number of outputs is increased to 87.

The Audio Outputs are electronically balanced with a nominal output level of 0.775mV (0dB). The maximum output level available is 4.5V (+15.5db)

Each Audio Output has 10 band parametric (plus bass and treble) equalisation, and an optional audio delay.

The Audio Outputs can be set to be either a “Zone” Audio output, a “Listen” output (to enable local monitoring in certain installations) or a “Reserve” Audio output.

All Audio Output settings are made in the “Audio Output” menus

4.2.2 “Zone” Audio Output Configuration

Figure 4.2 — Audio Output Menu Location

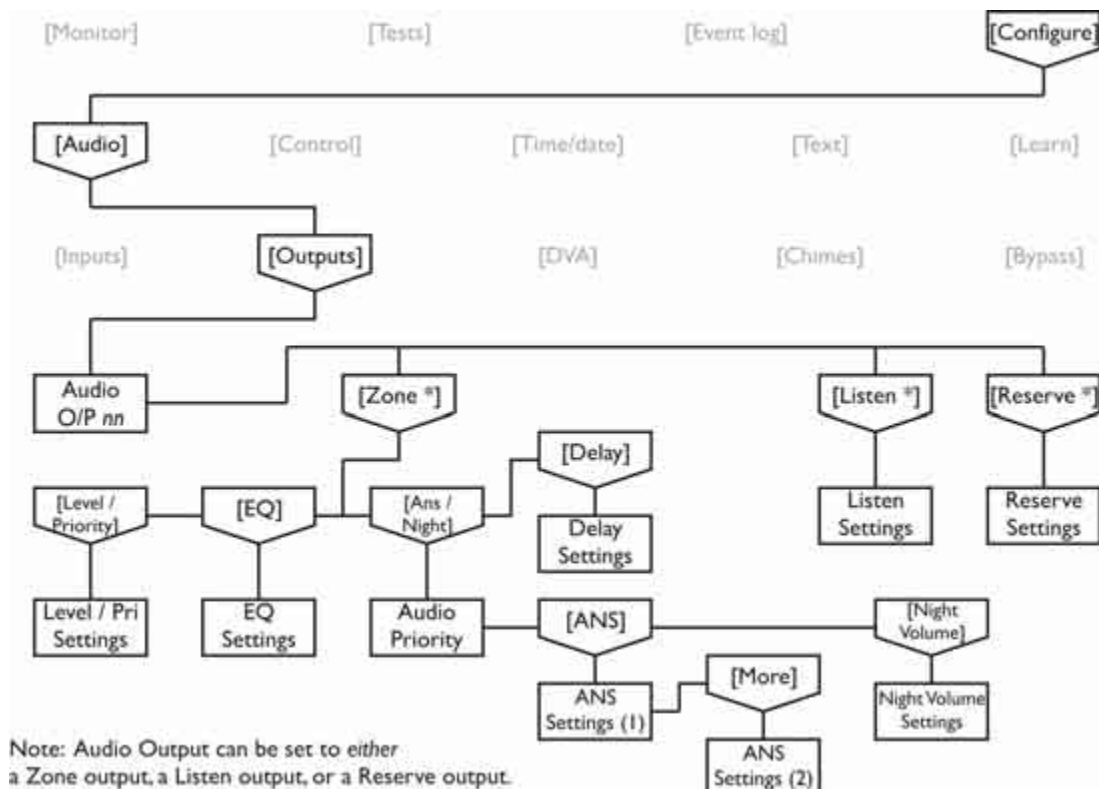

Navigate to the Audio Output menu (shown in Figure 3.5 on page 25) to adjust any of the Audio Output settings.

```
Audio O/P 01 (Aud OP 01 )
[Zone*] [Listen ] [Reserve ]
```



NOTE: The "" next to Zone indicates that this output is currently set to be a Zoned Audio Output.*

By turning the rotary encoder the required Audio Output can be selected, and the current status of that output will be displayed.

Select "Zone" to open the Zoned Audio Output Menu.

```
Audio O/P 01 (Aud OP 01 )
[Zone*] [Listen ] [Reserve ]
```

The Zoned Audio Output menu will then be displayed

```
Zone O/P 01 (Aud IP 01 )
[Level/Priority] [EQ] [ANS/Night] [Delay]
```

4.2.2.1 Level/Priority Settings

Select Level/Priority to open the Level/Priority menu.

```
Zone O/P 01 (Aud IP 01 )
[Level/Priority] [EQ] [ANS/Night] [Delay]
```

The Level/ Priority settings will then be displayed.

```
Zone O/P 01 (Aud IP 01 )
(I/P 01a Aud IP 01 ) (-12db/01)
```

From this menu, the output level and the priority of each input (when broadcast to this zone) can be set according to system requirements.

Audio Inputs 1 to 8 have two independent priority and level settings to allow the microphones to have dual mode facility.

The BVRD2M has 15 different Audio Priority settings (1 being the highest and 15 being the lowest), and any input can be set to any priority level.

If two or more routes have the same priority they will be served on a "first come, first served" basis.

The available settings are shown below.

```
Zone O/P 01 (Aud IP 01 )
(I/P 01a Aud IP 01 ) (-12db/01)
```

I/P 01 - I/P68	00dB	1
DVA01 - DVA30	-01dB	2
	-02dB	3

	-58dB	13
	-59dB	14
	-60dB	15

4.2.2.2 EQ Settings

Select EQ to open the EQ menu.

```
Zone O/P 01 (Aud IP 01 )
[Level/Priority] [EQ] [ANS/Night] [Delay]
```

The available settings are shown below.

```
Zone O/P 01 (Aud IP 01 )
(Filter 01) ( 00dB) (Freq 100Hz) (1/3 oct)
```

Filter 01	+12dB	Freq 50 Hz	1/10 oct
Filter 02	+11dB	Freq 63 Hz	1/5 oct
Filter 03	+10dB	Freq 80 Hz	1/3 oct
Filter 04	+09dB	Freq 100 Hz	1/2 oct
Filter 05	+08dB	Freq 125 Hz	2/3 oct
Filter 06	+07dB	Freq 160 Hz	1 oct
Filter 07	+06dB	Freq 200 Hz	2 oct
Filter 08	+05dB	Freq 250 Hz	
Filter 09	+04dB	Freq 315 Hz	
Filter 10	+03dB	Freq 400 Hz	
	+02dB	Freq 500 Hz	
	+01dB	Freq 630 Hz	
	00dB	Freq 800 Hz	
	-01dB	Freq 1K00	
	-02dB	Freq 1K25	
	-03dB	Freq 1K60	
	-04dB	Freq 2K00	
	-05dB	Freq 2K50	
	-06dB	Freq 3K15	
	-07dB	Freq 4K00	
	-08dB	Freq 5K00	
	-09dB	Freq 6K30	
	-10dB	Freq 8K00	
	-11dB	Freq 10K00	
	-12dB	Freq 12K50	
		Freq 16K00	

Low Filter Settings

The Low filter settings are shown below.

Zone	O/P 01	(Aud IP 01)
(Filter LQ) (00dB) (Freq 1K00) (06dB/oct)			
	+12dB	Freq 250 Hz	03dB/oct
	+11dB	Freq 315 Hz	
	+10dB	Freq 400 Hz	
	...	Freq 500 Hz	
	...	Freq 630 Hz	
	...	Freq 800 Hz	
	...	Freq 1K00	
	...	Freq 1K25	
	-10dB	Freq 1K60	
	-11dB	Freq 2K00	
	-12dB	Freq 2K50	

High Filter Settings

The High filter settings are shown below.

Zone	O/P 01	(Aud IP 01)
(Filter HI) (00dB) (Freq 1K00) (06dB/oct)			
	+12dB	Freq 500 Hz	3dB/oct
	+11dB	Freq 630 Hz	
	+10dB	Freq 800 Hz	
	...	Freq 1K00	
	...	Freq 1K25	
	...	Freq 1K60	
	...	Freq 2K00	
	...	Freq 2K50	
	-10dB	Freq 3K15	
	-11dB	Freq 4K00	
	-12dB	Freq 5K00	

4.2.2.3 Ambient Noise Sensing / Night Volume

Select ANS/Night to open the Ambient Noise Sensing / Night Volume menu.

Zone	O/P 01	(Aud IP 01)
[Level/Priority] [EQ] [ANS/Night] [Delay]			

The ANS /Night menu will then be displayed.

Zone	O/P 01	(Aud IP 01)
(Audio pri 00-00) [ANS] [Night volume]			

The Ambient Noise and Night Volume settings can be set to only affect a range of Priorities for the relevant output.

This range setting includes the priorities indicated (e.g. Audio pri 03-05 will affect priorities 3, 4, and 5).

Ambient Noise Settings

Select ANS to enter the ANS menu.

```
Zone O/P 01 (Aud IP 01 )
(Audio pri 00-00) [ANS] [Night volume]
```

The first ANS options menu will then be displayed.

```
Zone O/P 01 (Aud IP 01 )
(Sens-60dB,prog attenuation -00dB) [More]
```

Sens -60db - 00dB

Select **M**ore for next Menu

The second ANS options menu will then be displayed.

```
Zone O/P 01 (Aud IP 01 )
(Range-20dB) (Speed Slow) [More]
```

Range -30db - 00dB

Slow
Medium
Fast

Select **M**ore
for next
Menu

The third ANS options menu will then be displayed.

```
Zone O/P 01 (Aud IP 01 )
(Analog Control I/P 00) (Busy Freeze N)
```

I/P 01 - 04
I/P 07 - 86

N
Y

The Analog Inputs must be capable of being pulled down for use with Ambient Noise Sensors.

Inputs 01-04 can be pulled down using the switch on the rear panel of the VIGIL EVAS BVRD2M, inputs 07-86 can be pulled down (in banks of four) using the jumpers on the relevant BVRCI card.

Inputs 5 and 6 cannot be pulled down so cannot be used for Ambient Noise Sensing.

Night Volume Settings

Select Night Volume to enter the Night Volume menu.

```
Zone O/P 01 (Aud IP 01 )
(Audio pri 00-00) [ANS] [Night volume]
```

The available options are shown below.

```
Zone O/P 01 (Aud IP 01 )
(Day MON) (Max 00:00/Min 00:00) (atten-00)
```

MON	00:10	00:10	00
TUE	00:20	00:20	-01
WED	00:30	00:30	-02
THU
FRI	23:30	23:30	-28
SAT	23:40	23:40	-29
SUN	23:50	23:50	-30
	Incs of 10 Mins	Incs of 10 Mins	

4.2.2.4 Audio Output Delay Settings

Select Delay to open the Audio Output Delay menu.

```
Zone O/P 01 (Aud IP 01 )
[Level/Priority] [EQ] [ANS/Night] [Delay]
```

The available settings are shown below.

```
Zone O/P 01 (Aud IP 01 )
Audio output delay 0000 mS
```

0 to 49mS	increments of 1mS
50 to 99mS	increments of 2mS
100 to 1000mS	increments of 5mS

4.2.3 “Listen” Audio Output Configuration

Figure 4.3 — Listen Audio Output Menu

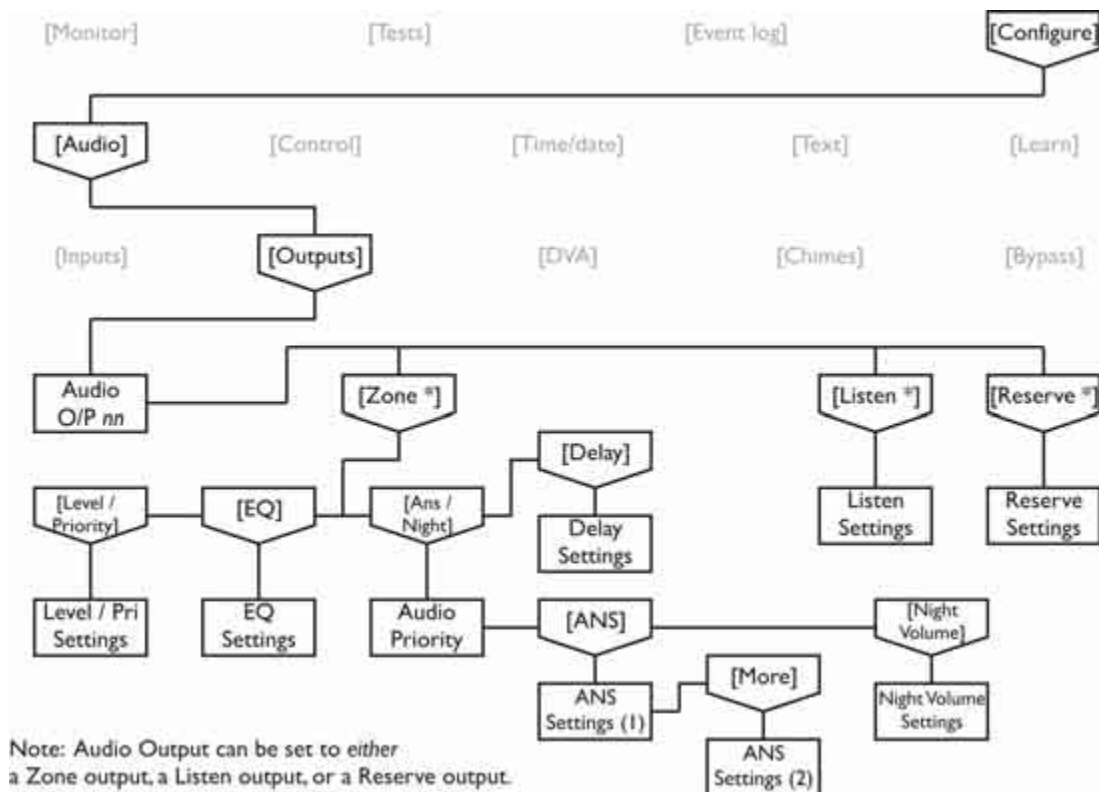

Navigate to the Audio Output menu to adjust any of the Audio Output settings.

```
Audio O/P 01 (Aud OP 01 )
[Zone*] [Listen ] [Reserve ]
```



NOTE: The "*" next to Zone indicates that this output is currently set to be a Zoned Audio Output.

By turning the rotary encoder the required Audio Output can be selected, and the current status of that output will be displayed.

Select “Listen” to open the Listen Audio Output Menu.

```
Audio O/P 01 (Aud OP 01 )
[Zone ] [Listen*] [Reserve ]
```

The Listen Audio Output menu will then be displayed.

```
List O/P 01 (Aud OP 01 )
Listen at I/P 01 Aud IP 01
```

Select the input that has the relevant BVM Microphone attached.

It is possible to select any Output to be a Listen output, however it is recommended that only outputs 14-17, 30-33, 46-49, 62-65, or 78-81 inclusive are used. These have a “Bypass All Call Enable” option (selected by DIL SW on the rear panel of the BVRD2S) to prevent an all call from being sent to the Listen output.

4.2.4 “Reserve” Audio Output Configuration

Figure 4.4 — “Reserve” Audio Output Menu Location

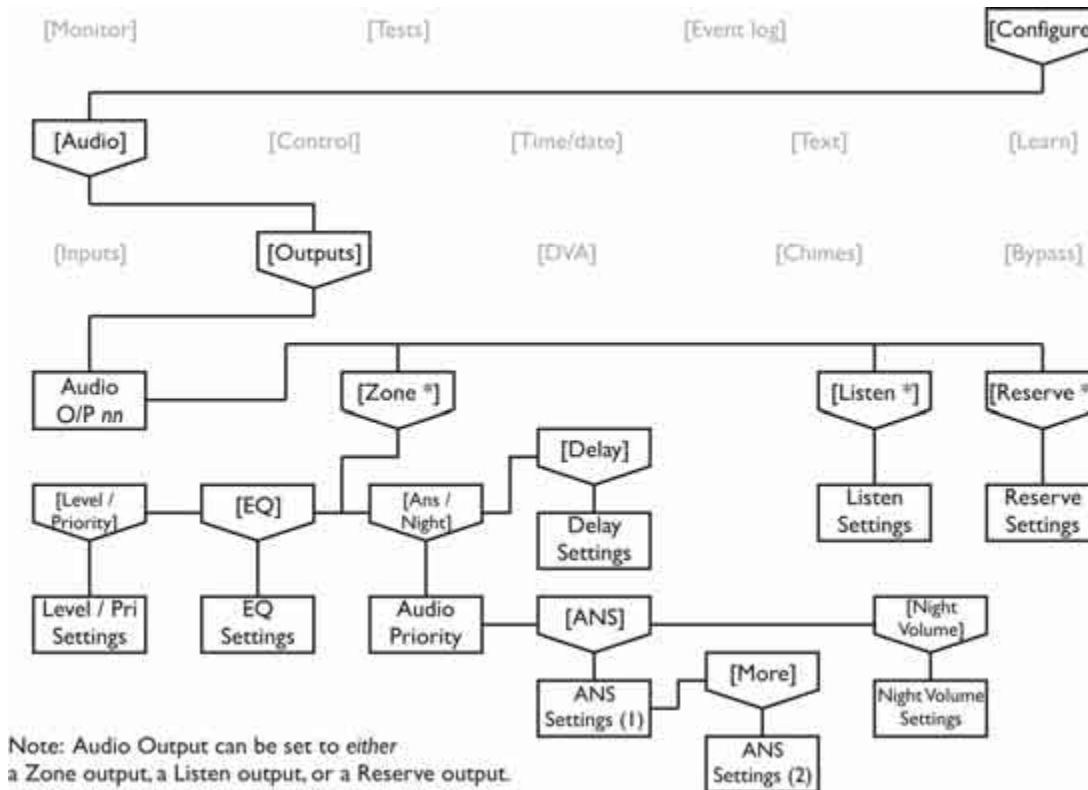

Navigate to the Audio Output menu to adjust any of the Audio Output settings.

```
Audio O/P 01 (Aud OP 01 )
[Zone*] [Listen ] [Reserve ]
```



NOTE: The "*" next to Zone indicates that this output is currently set to be a Zoned Audio Output.

By turning the rotary encoder the required Audio Output can be selected, and the current status of that output will be displayed.

Select “Reserve” to open the Reserve Audio Output Menu.

```
Audio O/P 01 (Aud OP 01 )
[Zone ] [Listen ] [Reserve*]
```

The available settings are shown below.

```
Audio O/P 01 (Aud OP 01 )
(Amp surv I/P 001-010) (Surv/priority N)
```

001-010	N
011-020	1
021-030	2
031-040	3
041-050	
051-060	
061-070	
071-080	
081-090	
091-100	
101-110	
111-120	
121-130	
131-140	
141-150	

Up to fifteen BVRDACO Canbus modules can be connected to the BVRD2M, each module monitoring ten amplifiers and loudspeaker lines.

For each bank of ten amplifiers a Reserve amplifier should be allocated. If an Amplifier failure is reported the BVRD2M will switch in the relevant Reserve amplifier, applying the routing information and volume levels etc. from the original output to the Reserve.

4.3 DVA MESSAGE SETTINGS

4.3.1 General Description

The BVRD2M can store up to 6 messages, each up to 57.3 seconds in length. The messages and all have independent surveillance and timing adjustments.

Each BVRD2S can store up to 12 additional messages, up to a maximum of 30 messages.

Each message time slot can be reduced to the message length if it is shorter than 57.3 seconds, and the repeat timer can be set to play the message after the required number of seconds (i.e. an alert message).

4.3.2 DVA Message Configuration

Figure 4.5 — DVA Configuration Menu Location

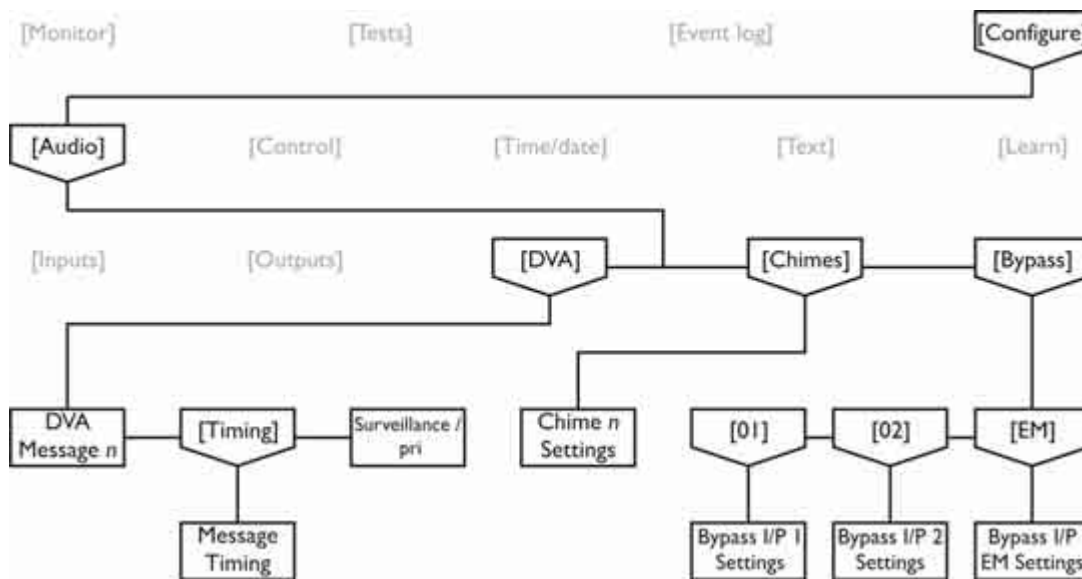

Navigate to the Audio Configuration DVA menu to adjust the DVA settings.

```
DVA Message 01 (Aud DVA 01 )
[Timing] (Surveillance/pri N)
```

The Surveillance Priority can be set to N, 1, 2, or 3.

Select “Timing” to open the Timing Menu.

```
DVA Message 01 (Aud DVA 01 )
[Timing] (Surveillance/pri N)
```

The available options are shown below:

```
DVA Message 01 (Aud DVA 01 )
(Repeat 015 Sec) (Full N) (Sync N)
```

Repeat 000 - 255 Sec	Full N	Sync N
	Full Y	Sync Y

The Repeat Time sets how often the message repeats. This can be set to just longer than the message length or could be set to give a period of silence after the message if required.

If Full is set to “Y” the whole message is played even if Access is removed. If set to “N” it will stop as soon as access is removed.

The Sync option is used to synchronise messages in a decentralised system. When set to Y the messages will be synchronised.

4.4 CHIMES

4.4.1 General Description

The BVRD2M can store up to 9 Pre-announcement Chimes or Tones, each of a maximum of 8 seconds length.

The Chimes all have independent timing adjustments.



NOTE: When a Chime (or Tone) is broadcast it is mixed with the relevant audio channel. Care should be taken to allow the Chime (or Tone) to finish before making an announcement.

4.4.2 Chime Configuration

Figure 4.6 — Chime Configuration Menu Location

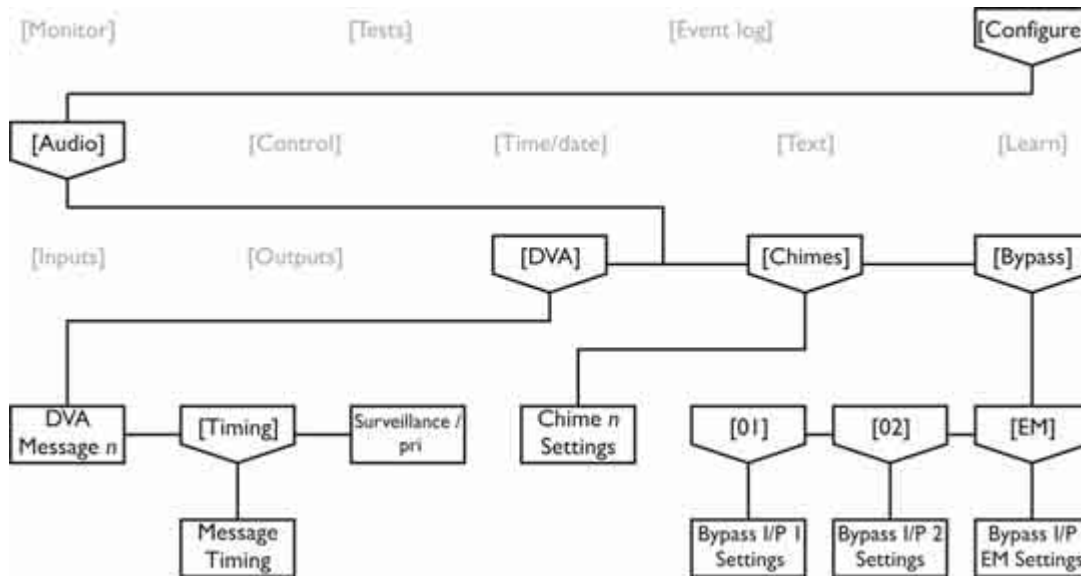

Navigate to the Chime Configuration menu to adjust the Chime settings.

```

Audio configuration
[Inputs] [Outputs] [DVA] [Chimes] [Bypass]
    
```

The Chime Duration Menu will then be displayed.

```

Chime 01 (Aud Chime 01 )
(Duration 0.05 Sec)
    
```

The Chime duration can be set from 0.00 seconds to 8.00 seconds, in 0.05 second increments.

4.5 BYPASS INPUTS

4.5.1 General Description

There are three input sources that can bypass all signal processing devices, in the event of failure, to perform a broadcast to all zone outputs.

Inputs 1 and 2, usually reserved for fire microphones, when accessed route their signals directly to all outputs via non volatile volume controls.

Under normal non fault conditions the evacuate message is stored in flash memory and is accessed by its associated DSP, however in the event of DSP failure a separate non processor derived fail-safe message will be broadcast to all zones.

All three of these inputs have independent level controls and the overall output level is set using a master control.

If zoning is required on input 1 or input 2 they will automatically be routed via the DSP using input 7 and 8 respectively.

In the bypass mode these three inputs have a fixed priority level where input 1 is the highest and the emergency message is the lowest.

4.5.2 Bypass Configuration

Figure 4.7 — Bypass Configuration Menu Location

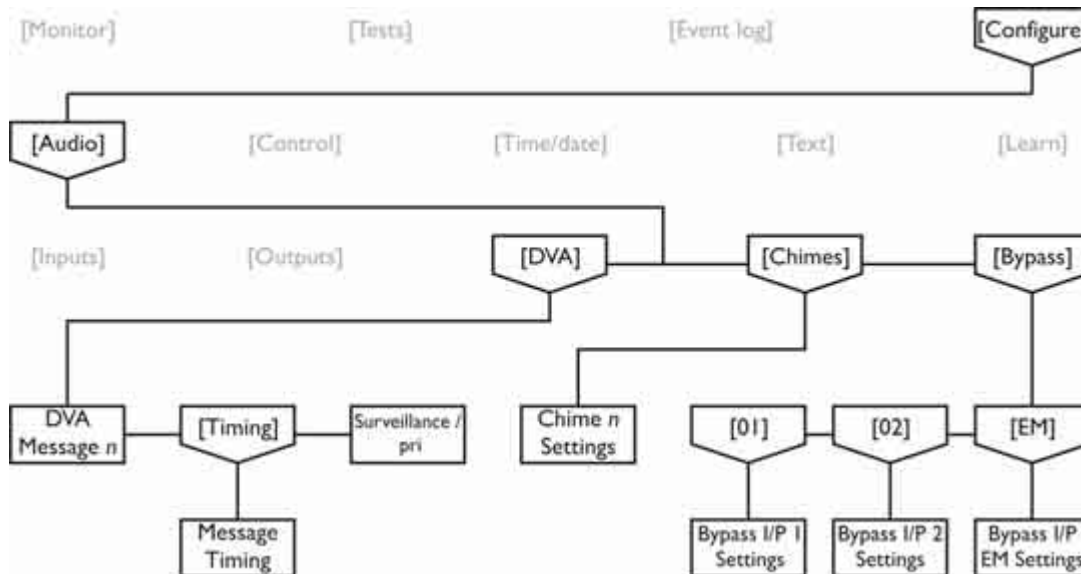

Navigate to the Bypass Configuration menu to adjust the Bypass settings.

```
Audio configuration
[Inputs] [Outputs] [DVA] [Chimes] [Bypass]
```

The Bypass Configuration Menu will then be displayed.

```
BYPASS inputs 01, 02 & Emergency Message
[01] [02] [EM] (Master level -15dB)
```

The Master Volume level can be set between -48dB and 0dB.

4.5.2.1 Input 01 Bypass Configuration

Select 01 to access the Bypass Configuration Menu for Input 01.

```
BYPASS inputs 01, 02 & Emergency Message
[01] [02] [EM] (Master level -15dB)
```

The Bypass Configuration Menu will then be displayed.

```
Bypass input 01 (Aud IP 01 )
(Input Atten -20dB) (surv/priority N)
```

The only setting that can be adjusted is the Surveillance Priority, which can be set to 1, 2, 3 or N.

The Input Attenuator setting is displayed but cannot be adjusted in this menu, as it is set in the “Audio Input Configuration” menu for Input 1. Refer to Section 4.1.2.1 on page 32 for more details.

4.5.2.2 Input 02 Bypass Configuration

The settings for Input 02 are similar to that shown for Input 01.

4.5.2.3 Emergency Message Configuration

Select EM to access the Bypass Configuration Menu for the Emergency Message.

```
BYPASS inputs 01, 02 & Emergency Message
[01] [02] [EM] (Master level -15dB)
```

The available options are shown below:

```
Bypass input 01 (Aud IP 01 )
(Input Atten -20dB) (surv/priority N)
```

Atten -48dB - 00dB

N
1
2
3

4.6 ENTERING OR CHANGING NAMES OF INPUTS / OUTPUTS ETC

The names of all Inputs, Outputs, DVA Messages, and Faults can be changed to suit the installation.



NOTE: Access Level 4 or above is required to change the names.

In the following example the name of Audio Output 3 will be changed.

1. Navigate to the Audio Output menu using the front panel controls:

Turn the key, enter the Level 4 access code, then move the cursor to the “Configure” option

```
Enter your PIN xxxx : Access Level 4
[Monitor] [Tests] [Event log] [Configure]
```

Press “Select” to enter the Configuration menu, then move the cursor to the “Audio” option.

```
Configuration
[Audio] [Control] [Time/date] [Text] [Learn]
```

Press “Select” to enter the Audio Configuration menu, then move the cursor to the “Outputs” option.

```
Audio configuration
[Inputs] [Outputs] [DVA] [Chimes] [Bypass]
```

The Audio Outputs menu will now be displayed.

```
Audio O/P 01 (Aud OP 01      )
[Zone*] [Listen ] [Reserve ]
```

2. Select Audio Output 3 using the Rotary Encoder

```
Audio O/P 03 (Aud OP 03      )
[Zone*] [Listen ] [Reserve ]
```

3. Press the Rotary Encoder to edit the Name - the cursor will appear under the first character.

```
Audio O/P 03 (Aud OP 03      )
[Zone*] [Listen ] [Reserve ]
```

4. Turn the Rotary Encoder to select the required character.

```
Audio O/P 03 (Rud OP 03      )  
[Zone*] [Listen ] [Reserve ]
```

5. Press the “Right” key to step to the next character.

```
Audio O/P 03 (Rud OP 03      )  
[Zone*] [Listen ] [Reserve ]
```

6. Turn the Rotary Encoder to select the required character.

```
Audio O/P 03 (Red OP 03      )  
[Zone*] [Listen ] [Reserve ]
```

7. Press the “Right” key to step to the next character.

```
Audio O/P 03 (Red OP 03      )  
[Zone*] [Listen ] [Reserve ]
```

8. Turn the Rotary Encoder to select the required character.

```
Audio O/P 03 (Rec OP 03      )  
[Zone*] [Listen ] [Reserve ]
```

9. Continue to enter the required text, and when completed press the Rotary Encoder. The cursor will return to the Audio Output number and the name change will be stored.

```
Audio O/P 03 (Reception      )  
[Zone*] [Listen ] [Reserve ]
```

5 System Configuration - Control Settings

5.1 GENERAL DESCRIPTION

The BVRD2M provides the following Control Inputs and Outputs:

- Two opto-coupled inputs (for configuration details refer to section 5.2.1 & section 5.2.2),
- Six analog control inputs (refer to section 5.2.3)
- Three simple contact closure inputs (refer to section 5.2.4),
- Six open collector outputs (refer to section 5.3),
- Two RS485 Communication Ports (refer to section 5.5).

By utilising CANBUS modules the maximum number of control inputs and outputs available is increased to:

- 50 opto-coupled inputs (using 2 BVRDFPI modules),
- 86 analog control inputs (using 5 BVRDCI modules),
- Three simple contact closure inputs,
- 26 open collector outputs (using 5 BVRDCI modules),
- 20 volt free relay contacts (using 5 BVRDCI modules).

5.1.1 Opto-coupled Inputs

The BVRD2M provides two opto-coupled inputs. These are the "All Evacuate" Opto EM and Opto #1.

The "All Evacuate" Opto EM input has a processor bypass and can only be used to evacuate all zones.

Under normal conditions, operation of the EM input will broadcast the selected message from the DSP message store using the full facilities provided by the DSP.

Should a fault occur within the unit it will be detected and the independent emergency message will be broadcast to all zones, bypassing all processing devices.

The Opto EM input is configured by a hard ware jumper link mounted on the BVRD2M to be normally de-energised (N/O) or energised (N/C) and may be programmed to latch.

The 2nd Opto input available on the BVRD2M is designated as Opto #1 and the 1st input on the 1st CANBUS module is Opto #2 and so on.

The Opto #1 input (as with the Opto inputs on the CANBUS module) can be programmed N/O or N/C, latching or non-latching and routing of messages to outputs.

5.1.2 Analogue Control Inputs

There are 6 analogue control inputs available on the BVRD2M, designated Analogue 1 to 6.

Inputs 1 to 4 can be collectively selected via a rear panel mounted switch on the BVRD2M to be either pulled high or pulled low (ANS only) by a 6k0 resistor.

Inputs 5 and 6 have a pull up facility only.

The 1st input on the CANBUS module is analogue input 7 and can be selected (in banks of 4) by a pin header mounted on the module to be either pulled high or pulled low (ANS only) by a 6k0 resistor.

5.1.3 Simple Contact Closure Inputs

Three simple contact closure inputs are available on the BVRD2M only.

5.1.3.1 PTT Priority - Multiple Inputs to Single Output

If the Contact Inputs are set to be PTT inputs then it is possible to route more than one input to an output, and only provide access if the PTT of the associated audio input is also taken to 0V.

This enables several microphones to share a common zone select highway and the PTT determines the audio input to be routed.

The Audio Input Priority must be at the same level for each input to achieve "1st come 1st served". If a microphone is already using a zone and another tries to select it the request is ignored, however any zone not previously selected will be accessed.

5.1.4 Open Collector Outputs

There are 6 open collector outputs available on the BVRD2M and are designated control outputs 1 to 6, the 1st output on the CANBUS module is control output 7.

5.2 CONTROL - INPUT CONFIGURATION

Figure 5.1 — Control Input Menu Location

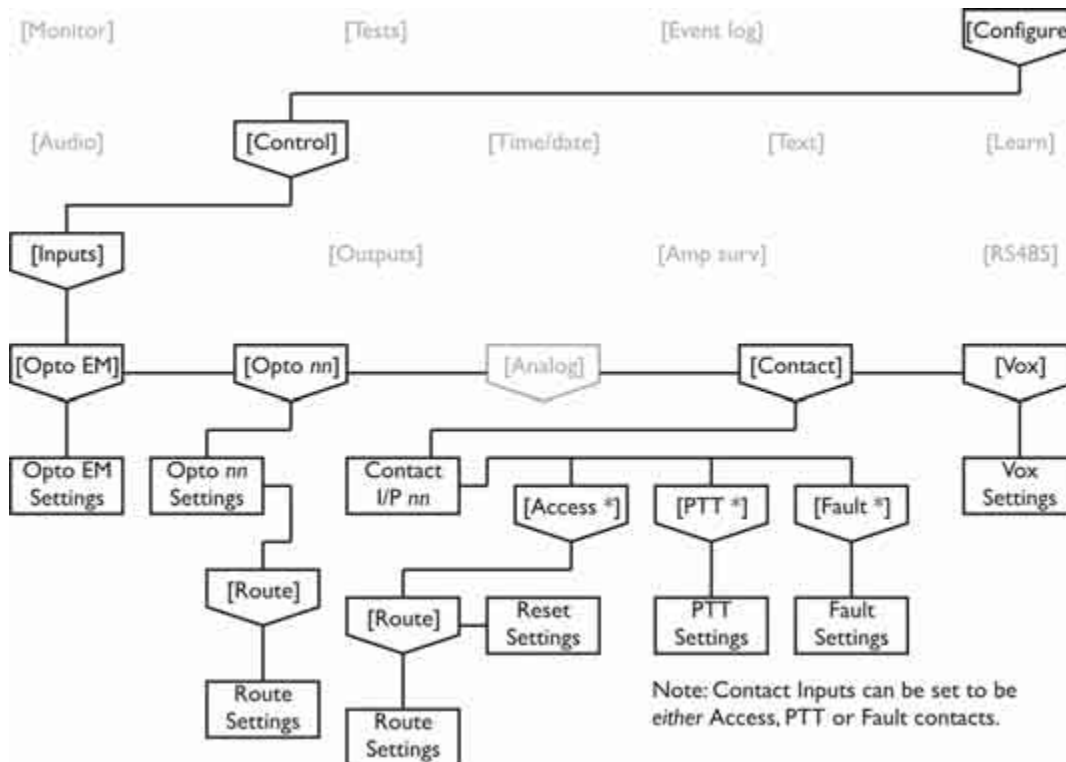

Navigate to the Control Menu as shown in Figure 3.7 on page 27.

```
Control
[Inputs] [Outputs] [Amp surv] [RS485]
```

Select Inputs to open the Control Inputs Menu.

```
Control Inputs
[Opto EM] [Opto nn] [Analog] [Contact] [VOX]
```

5.2.1 Opto EM Input Configuration

Select Opto EM to open the Control Input menu for the Emergency Message.

```
Control Inputs
[Opto EM] [Opto nn] [Analog] [Contact] [VOX]
```

The available settings are shown below:

```
Opto I/P EM ALL ZONE EMERGENCY MESSAGE
(Reset NONE 00) (DVA 01 Aud DVA 01 )
```

Opto 01 to 49 00 to 30
Analog 01 to 86
Contact 01 to 03
(Not Latched) None 00

The Opto EM Input is set to either normally de-energised (N/O) or energised (N/C) by the internal "EVAC ALL MODE" hardware jumper inside the BVRD2M.

If the Reset Option is set to anything other than "None 00" then the Opto EM input will latch and not release until the relevant input is energised.

If the DVA Message is set to 00 then the "Bypass" EPROM message will be broadcast to all zones instead of one of the DVA Messages.

5.2.2 Opto nn Input Configuration

Select Opto nn to open the Control Input menu for the Opto Inputs.

```
Control Inputs
[Opto EM] [Opto nn] [Analog] [Contact] [VOX]
```

The available options are shown below.

```
Opto I/P 01 (Ctrl Opto nn 01)
[Route] (Reset NONE 00) (Mode N/O)
```

Opto 01 to 49 N/O
Analog 01 to 86 N/C
Contact 01 to 03
(Not Latched) None 00

If the Reset Option is set to anything other than "None 00" then the Opto Input will latch and not release until the relevant input is energised.

5.2.2.1 Route Settings

Select Route to open the Route Menu for the Opto Input.

```
Opto I/P 01 (Ctrl Opto nn 01)
[Route] (Reset NONE 00) (Mode N/O)
```

The available settings are as follows.

```
Opto I/P 01 (Ctrl Opto nn 01)
(O/P 01) (DVA 1st 00 2nd 00) (Del 00 x20s)
```

01 to 87 00 to 30 00 to 30 00 to 99

Each available audio output can have 1 or 2 messages assigned allowing for **pulsed** or **steady** outputs from the fire detection system, these are set as follows:

Steady Alarm State from Fire Detection System

If the fire detection system provides a steady alarm state, set "DVA 1st" for the message required, and set DVA 2nd to 00 for each audio output.

On receiving an alarm condition the 1st message will sound after 250ms (if the delay is set to 00).

Pulsed Alarm State from Fire Detection System

If the fire detection system provides a pulsing output (1 sec on, 1 sec off) for alert and a steady for evacuate, set "DVA 1st" to the Alert message and "DVA 2nd" to the Evacuate message for each audio output.

On receiving a steady evacuate alarm condition the 1st message will sound after 250ms, and the 2nd message after 3 seconds (if the delay is set to 00).

A delay may be set in increments of 20 seconds to provide phased evacuation if required.

5.2.3 Analogue Input Configuration

Figure 5.2 — Analog Control Input Menu Location

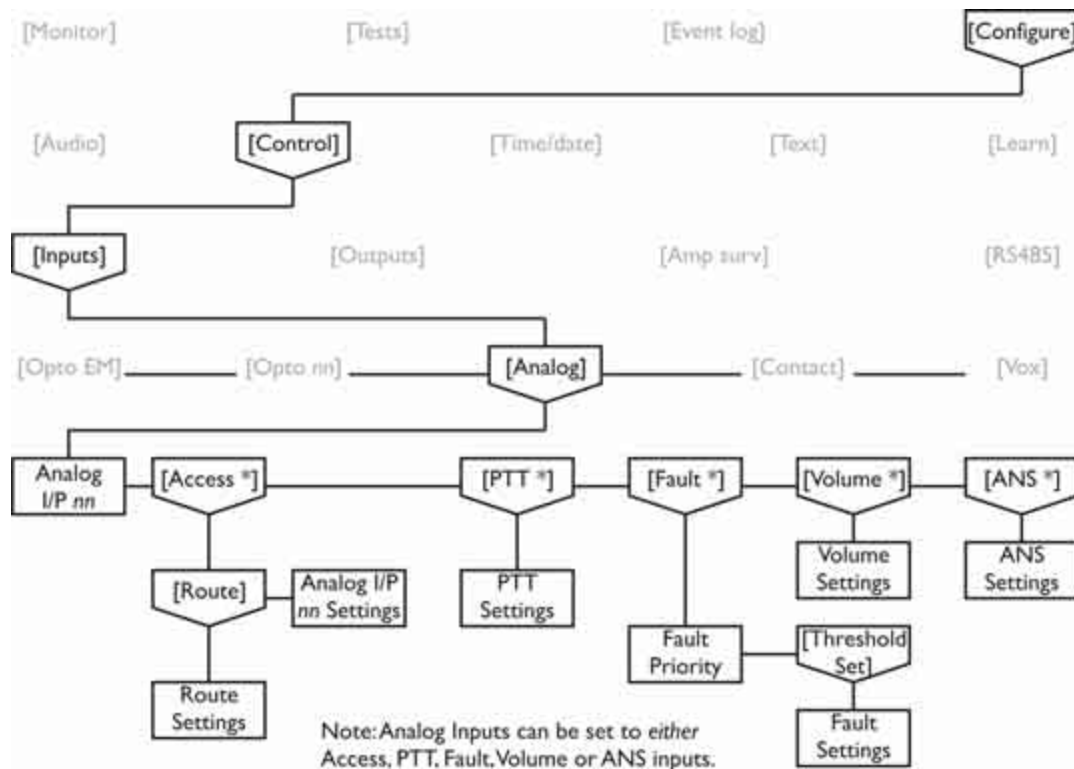

Select Analog to open the Control Input menu for the Analog Inputs.

```
Control Inputs
[Opto EM] [Opto nn] [Analog] [Contact] [VOX]
```

The Analog Input Menu is then displayed.

```
Analog I/P 01 (Ctrl Analog 01)
[Access*] [PTT ] [Fault ] [Volume ] [ANS ]
```

Each Analog input can be set to be one of the following types of input:

- Access - monitored access for any input or DVA Message,
- PTT - unmonitored access for any audio input,
- Fault - provides a DC voltage "window" with a low and high threshold,
- Volume - remote volume control for a single output,
- ANS - monitored Ambient Noise Sensor input.

5.2.3.1 Analogue Access Input

Select Access to open the Analogue Access Input menu.

```

Analog I/P 01 (Ctrl Analog 01)
[Access*] [PTT ] [Fault ] [Volume ] [ANS ]
    
```



NOTE: The "" next to Access indicates that this input is currently set to be a Monitored Access input.*

The available options are shown below.

```

Analog I/P 01 (Ctrl Analog 01 )
[Route] (Surv/pri N) (Reset NONE 00)
    
```

N	Opto 01 to 49
1	Analog 01 to 86
2	Contact 01 to 03
3	(Not Latched) None 00

If the Reset Option is set to anything other than "None 00" then the Access Input will latch and not release until the relevant input is energised.

Analogue Access Route Settings

Select Route to open the Route Menu for the Access Input.

```

Analog I/P 01 (Ctrl Analog 01 )
[Route] (Surv/pri N) (Reset NONE 00)
    
```

The available settings are as follows.

```

Analog I/P 01 (Ctrl Analog 01 )
I/P 01a Aud IP 01 O/P 01 Aud OP 01 (Y)
    
```

I/P 01 to 68	01 to 87	Y
DVA 01 to 30		N

Select (Y) to route the selected input to the selected output, or (N) to only set up the route and not make it active.

5.2.3.2 PTT Input Settings

Select PTT to open the PTT Input menu.

```

Analog I/P 01 (Ctrl Analog 01)
[Access*] [PTT ] [Fault ] [Volume ] [ANS ]
    
```



NOTE: The "" next to Access indicates that this input is currently set to be a Monitored Access input.*

The available options are shown below.

```

Analog I/P 01 (Ctrl Analog 01)
(Audio I/P 01a Aud IP 01 )
    
```

I/P 01-68

5.2.3.3 Fault Input Settings

Select Fault to open the Fault Input menu.

```

Analog I/P 01 (Ctrl Analog 01)
[Access*] [PTT ] [Fault ] [Volume ] [ANS ]
    
```



NOTE: The "" next to Access indicates that this input is currently set to be a Monitored Access input.*

The Fault Input menu will be displayed.

```

Analog I/P 01 (Ctrl Analog 01 )
(Fault pri N) [Threshold set]
    
```

Select either N, 1, 2, or 3 as the fault priority.

Select Threshold to open the Threshold Menu.

```

Analog I/P 01 (Ctrl Analog 01 )
(Volt low 00.0) (Volt high 00.0)
    
```

0.0V to 21.0V & Off 0.0V to 21.0V & Off Incs of 0.2V

5.2.3.4 Remote DC Volume Settings

Select Volume to open the DC Remote Volume input menu.

```
Analogue I/P 01 (Ctrl Analogue 01)
[Access*] [PTT ] [Fault ] [Volume ] [ANS ]
```



NOTE: The "" next to Access indicates that this input is currently set to be a Monitored Access input.*

The available options are shown below.

```
Analogue I/P 01 (Ctrl Analogue 01 )
O/P 01 Aud OP 01 (N) (pri 00-00)
O/P 01-87 Y 00-15
N
```

5.2.3.5 Ambient Noise Input Settings

Select ANS to open the Ambient Noise Input menu.

```
Analogue I/P 01 (Ctrl Analogue 01)
[Access*] [PTT ] [Fault ] [Volume ] [ANS ]
```



NOTE: The "" next to Access indicates that this input is currently set to be a Monitored Access input.*

The available options are shown below.

```
Analogue I/P 01 (Ctrl Analogue 01)
ANS Surveillance/pri N
```

3
2
1
N

5.2.4 Contact Input Configuration

Figure 5.3 — Control Input Menu Location

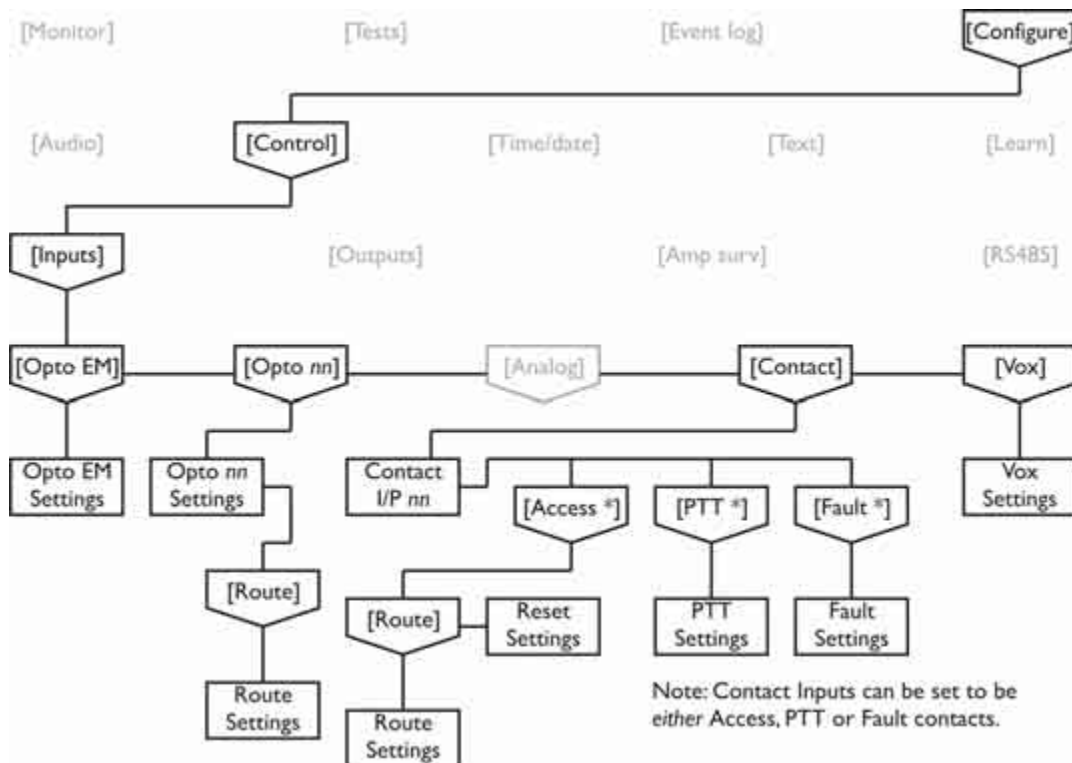

Select Contact to open the Control Input menu.

```
Control Inputs
[Opto EM] [Opto nn] [Analog] [Contact] [VOX]
```

The Contact Input Menu is then displayed.

```
Contact I/P 01 (Ctrl Contact 01 )
[Access*] [PTT ] [Fault ]
```

Each Contact Input can be set to be one of the following:

- Access - unmonitored Access contacts for Audio Inputs or DVA messages,
- PTT - unmonitored Press to Talk for Audio inputs,
- Fault - unmonitored Fault contacts, can be set for Normally Open or Normally Closed.

5.2.4.1 Contact Input Access Menu

Select Access to open the Contact Input Access Menu.

```
Contact I/P 01 (Ctrl Contact 01 )
[Access*] [PTT ] [Fault ]
```



NOTE: The "" next to Access indicates that this input is currently set to be an Access input.*

The available settings are as follows.

```
Contact I/P 01 (Ctrl Contact 01)
[Route] (Reset NONE 00)
```

Opto 01 to 49
Analog 01 to 86
Contact 01 to 03
(Not Latched) None 00

If the Reset Option is set to anything other than "None 00" then the Access Input will latch and not release until the relevant input is energised.

Contact Input Access Route Menu

Select Route to open the Contact Input Access Route Menu.

```
Contact I/P 01 (Ctrl Contact 01)
(I/P 01a Aud IP 01 ) (O/P 01 Aud OP 01(N)
```

I/P 01 to 68	01 to 87	Y
DVA 01 to 30		N

Select (Y) to route the selected input to the selected output, or (N) to only set up the route and not make it active.

5.2.4.2 PTT Contact Input Menu

Select PTT to open the "Press to Talk" Contact Input Menu.

```
Contact I/P 01 (Ctrl Contact 01 )
[Access ] [PTT*] [Fault ]
```

The available settings are as follows.

```
Contact I/P 01 (Ctrl Contact 01 )
(Audio I/P 01a Aud IP 01 )
```

I/P 01 to 68

5.2.4.3 Fault Contact Input Menu

Select Fault to open the Fault Contact Input Menu.

```
Contact I/P 01 (Ctrl Contact 01 )
[Access ] [PTT ] [Fault*]
```

The available settings are as follows.

```
Contact I/P 01 (Ctrl Analog 01)
(Mode N/O) (Fault Priority N)
```

N/O
N/C

N
1
2
3

5.2.5 VOX Input Configuration

Figure 5.4 — Control Input Menu Location

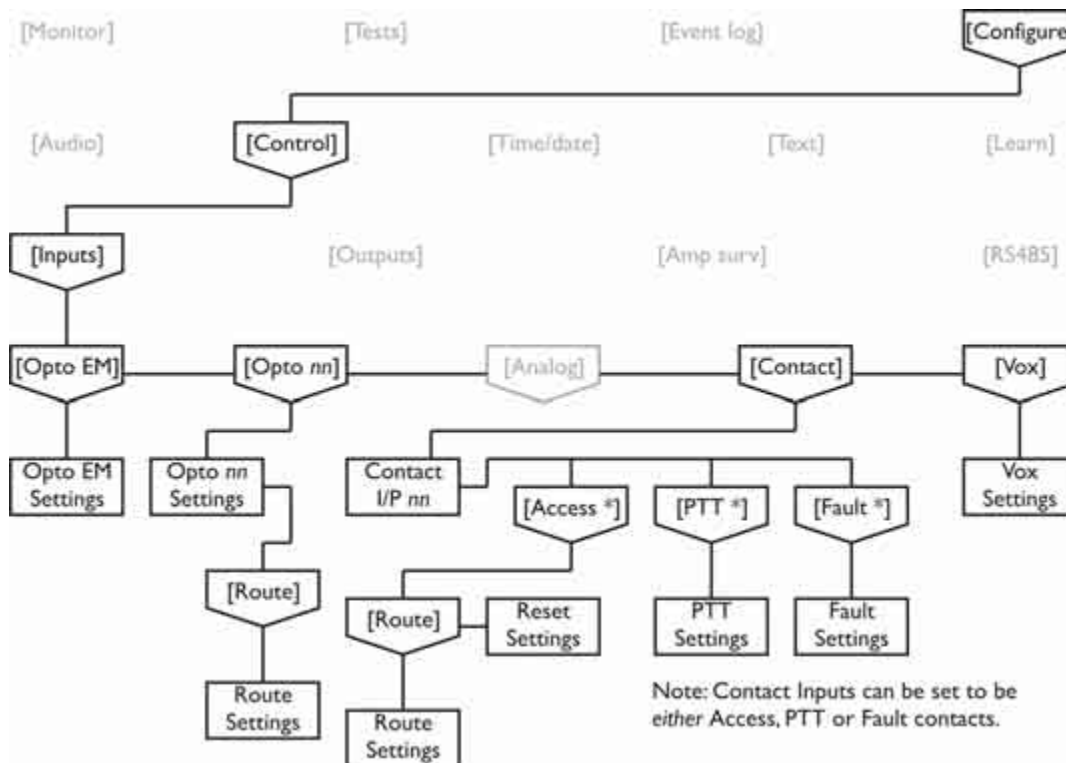

Select VOX to open the VOX Input menu.

```
Control Inputs
[Opto EM] [Opto nn] [Analog] [Contact] [VOX]
```

The available settings are shown below.

```
Audio I/P 01 (Aud IP 01 )
(Sens -15dB) (O/P 01 Aud OP 01 ) (N)
00 to -60dB 01 to 87 Y
N
```

Select (Y) to route the selected input to the selected output, or (N) to only set up the route and not make it active.

5.3 CONTROL - OUTPUT CONFIGURATION

Figure 5.5 — Control Outputs Menu Location

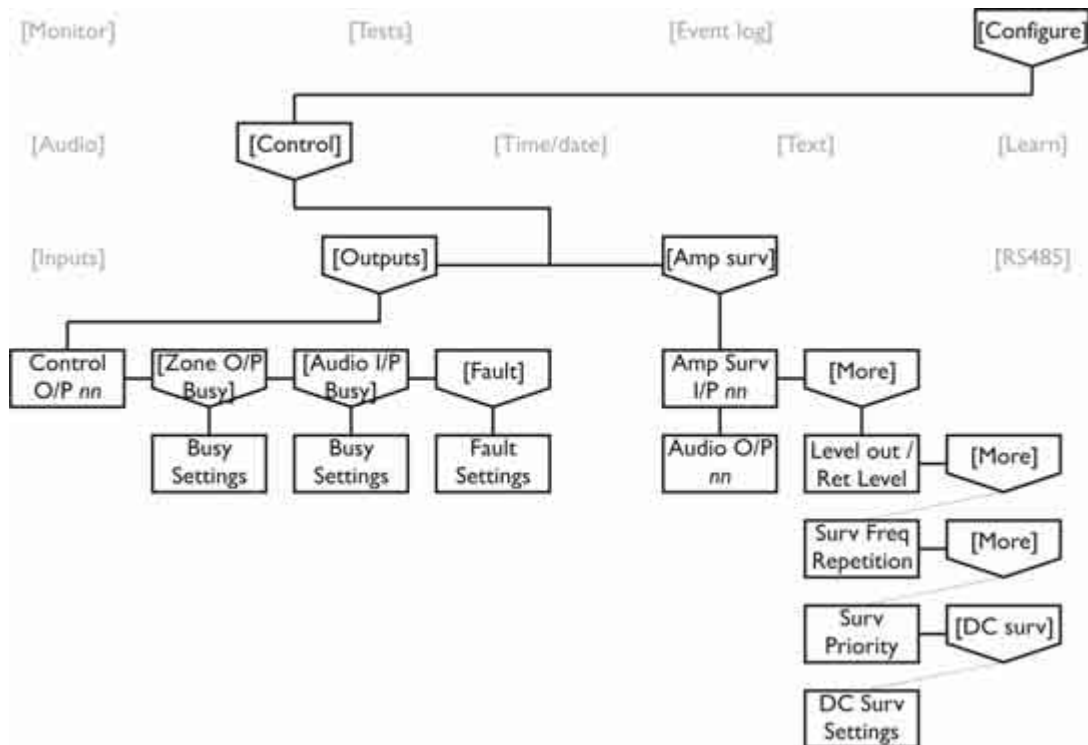

Navigate to the Control Output Menu.

```
Control
[Inputs] [Outputs] [Amp surv] [RS485]
```

Select Outputs to open the Control Outputs Menu.

```
Control O/P 01 (Ctrl Output 01 )
[Zone OP busy*] [Audio IP busy ] [Fault ]
```

Each Control Output can be set be one of the following types of input:

- Zone Output Busy - made active when selected zone is made busy by an input within the specified Audio Priority range,
- Audio Input Busy - made active when the selected Audio Input or DVA message is active,
- Fault - made active if any fault is detected with the selected input or DVA Message.

5.3.1 Zone Output Busy Configuration

Select Zone OP Busy to open the Zone OP Busy menu.

```
Control O/P 01 (Ctrl Output 01 )
[Zone OP busy*] [Audio IP busy ] [Fault ]
```

The available settings are as follows.

```
Control O/P 01 (Ctrl Output 01 )
(O/P 01 Aud OP 01 ) (N) (Pri 00-00)
```

01 to 87	Y	00 to 15
	N	

Select (Y) to route the selected output, or (N) to only set up the route and not make it active.

5.3.2 Audio Input Busy Configuration

This feature is not yet implemented.

5.3.3 Fault Busy Configuration

This feature is not yet implemented.

5.4 CONTROL - AMPLIFIER SURVEILLANCE CONFIGURATION

Figure 5.6 — Amplifier Surveillance Menu Location

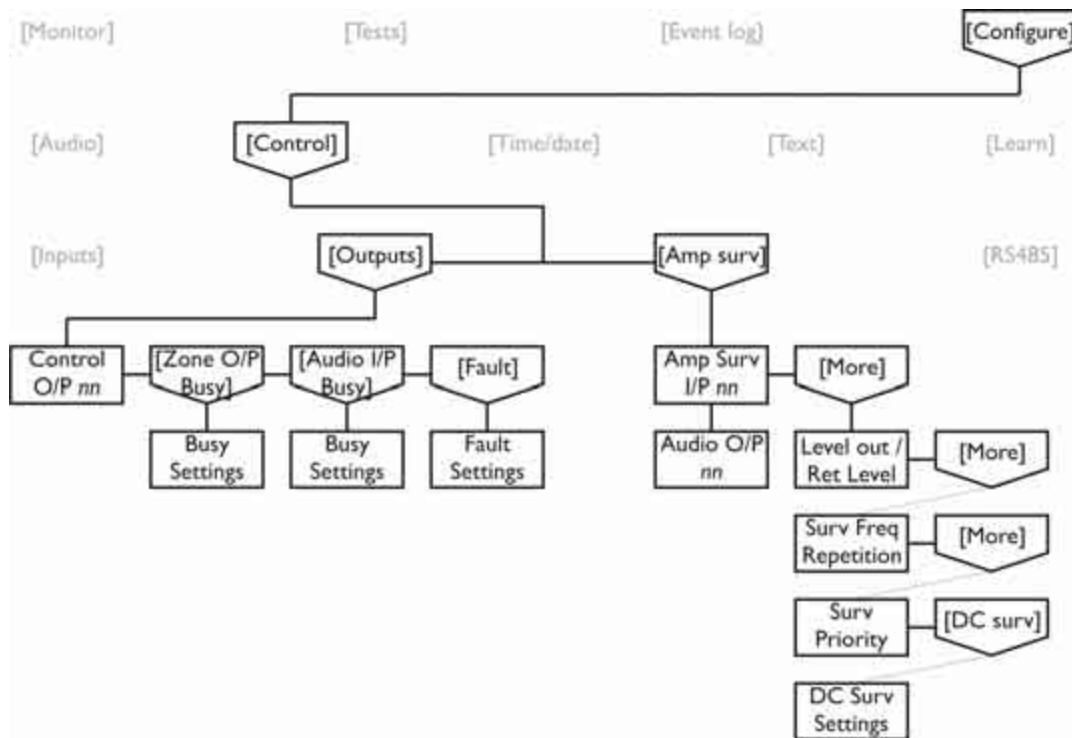

NOTE: These settings relate to Amplifier Surveillance using BVRDACO CANBUS Modules.

Each BVRDACO can accommodate up to 10 amplifiers with one reserve, with a maximum of 15 cards (providing 150 amplifier surveillance inputs) per system.

5.4.1 Surveillance Configuration

Navigate to the Control Menu as shown in Figure 3.9 on page 29 and select Amp Surv to open the Amplifier Surveillance Menu.

```
Control
[Inputs] [Outputs] [Amp surv] [RS485]
```

The available settings are as follows.

```
Amp surv I/P 01 (Ctrl Amp Surv 01)
(Audio O/P 01 Aud OP 01 ) [More]
```

01 to 87

Select [More] for
surveillance level menu

Select the correct audio Output that is feeding the amplifier connected to the selected Amplifier Surveillance Input.

5.4.2 Surveillance Level Configuration

Select [More] to open the next Surveillance Menu.

```
Amp surv I/P 01 (Ctrl Amp Surv 01)
(Audio O/P 01 Aud OP 01 ) [More]
```

The Surveillance Level settings are as follows.

```
Amp surv I/P 01 (Ctrl Amp Surv 01)
(Level out -48dB)Return Level 0.0v [More]
```

00 to -48dB The returned voltage is Select [More]
displayed here 0.0 to 9.9V for next menu

The Return Voltage Level from the BEL1 is displayed.

5.4.3 Surveillance Frequency Configuration

Select [More] to open the next Surveillance Menu.

```
Amp surv I/P 01 (Ctrl Amp Surv 01)
(Level out -48dB)Return Level 0.0v [More]
```

The Surveillance Level settings are as follows.

```
Amp surv I/P 01 (Ctrl Amp Surv 01)
(Surv Freq OFF) (Repetition Cont) [More]
```

OFF	Continuous	Select [More]
30H	10s	for next menu
20K	20s	
	30s	
	40s	
	50s	
	60s	

5.4.4 Surveillance Fault Priority Configuration

Select [More] to open the next Surveillance Menu.

```
Amp surv I/P 01 (Ctrl Amp Surv 01)
(Surv Freq OFF) (Repetition Cont) [More]
```

The Surveillance Fault Priority settings are as follows.

Amp surv I/P 01 (Ctrl Amp Surv 01)
Surv pri (Amplifier N) (Earth N) [DC surv]

1	1
2	2
3	3
N	N

5.4.5 DC Line Surveillance

This feature is not implemented.

5.5 CONTROL - RS485 PORT CONFIGURATION

Figure 5.7 — RS485 Port Menu Location

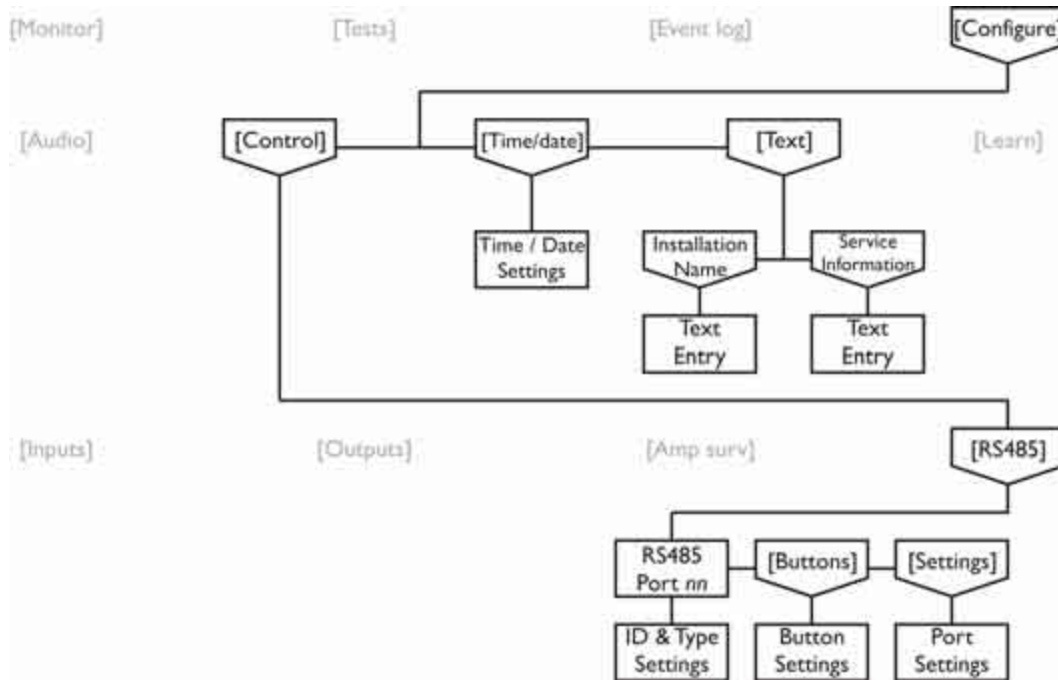

NOTE: The RS485 Configuration settings shown in this section enable compatibility with the BVRM range of Intelligent Microphones.

Navigate to the Control Menu as shown in Figure 3.10 on page 30 and select RS485 to open the RS485 Menu.

```
Control
[Inputs] [Outputs] [Amp surv] [RS485]
```

The available settings are as follows.

```
RS485 port 01 (RS485 Port 001)Gp(*) (*)
[Buttons] (ID 000) [Settings] (Type 0)
```

000 to 127

0 to 9

5.5.1 ID# Configuration

The ID# sets the address of the BVRD2M on the selected port.

```
RS485 port 01 (RS485 Port 001)Gp(*) (*)
[Buttons] (ID 000) [Settings] (Type 0)
```

This is normally set to 000 for a system with a single master. For systems using multiple master units, the ID#s would normally be set 001, 002 etc.

If multiple ports are in use, to avoid confusion it is recommended to ensure BVRD2M units have identical ID#s for each port.

5.5.2 Type Configuration

Specifies the communications protocol for the selected port.

```
RS485 port 01 (RS485 Port 001)Gp(*) (*)
[Buttons] (ID 000) [Settings] (Type 0)
```



NOTE: Type "0" protocol must be selected to enable communication with the BVRM range of microphones.

5.5.3 Button Configuration



NOTE: This section specifies Button allocation on BVRM microphones.

Select Buttons to open the Button Allocation menu.

```
RS485 port 01 (RS485 Port 001)Gp(*) (*)
[Buttons] (ID 000) [Settings] (Type 0)
```

The available settings are as follows.

```
RS485 port 01 (RS485 Port 001)Gp(*) (*)
(O/P 01 Audio Output 001) (Button 001)
```

00 to 87

000 to 127

The button settings determine which button on the BVRM Microphone is allocated to the selected output.

5.5.4 Settings Configuration

Select Settings to open the Port Settings menu.

```
RS485 port 01 (RS485 Port 001)Gp(*) (*)  
[Buttons] (ID 000) [Settings] (Type 0)
```

The port settings menu will then be displayed.

```
RS485 port 01 (RS485 Port 001)Gp(*) (*)  
(Baud= 1200) (Bits=7) (Par=N) (Stop=1)
```



NOTE: These specify the RS485 communication settings.

To communicate with BVRM microphones the settings must be as follows:

Baud = 9600 Bits=8 Par=E Stop=1

6 System Configuration - Time, Date and Text Settings

The BVRD2M contains a real time clock that is used for date stamping the event and fault logs, and also for controlling the Night Volume settings.



NOTE: The Date (including the day) must be set to ensure the automatic changes from GMT to BST occur correctly.

The text shown in on the LCD Display can be altered to state the Installation Name, and also provide contact details if a Fault is announced by the unit.

6.1 SETTING THE TIME & DATE

Figure 6.1 — Time & Date Menu Location

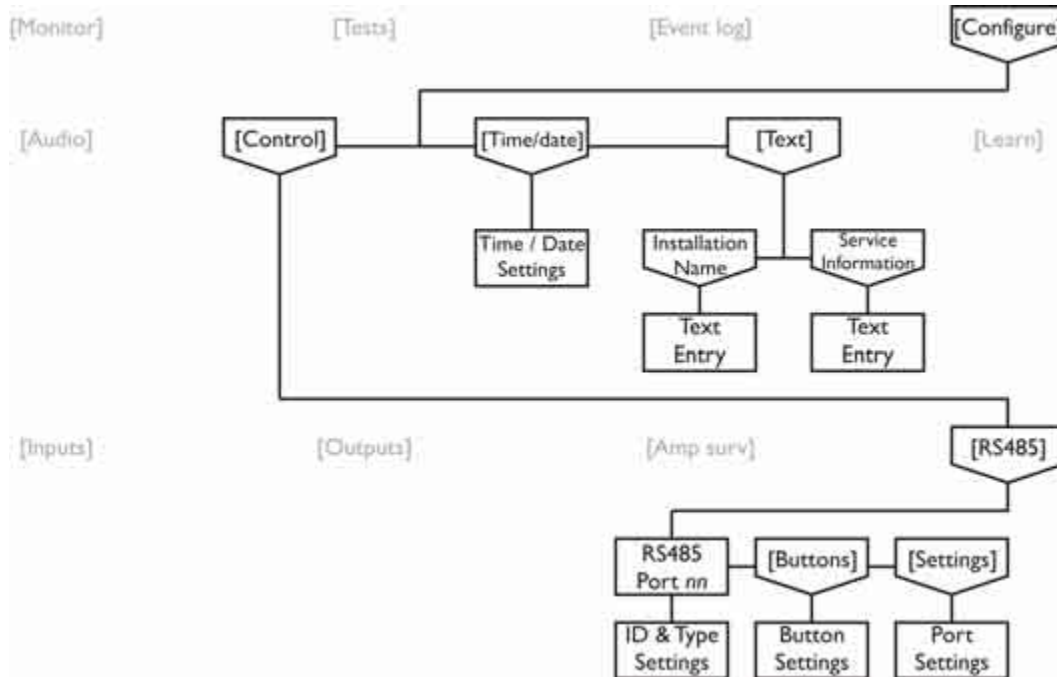

Navigate to the Configuration Menu.

```
Configuration
[Audio] [Control] [Time/date] [Text] [Learn]
```

Select Time/date to open the Time/Date Menu.

```
Configuration                               12:44:30
Time/Date                                   Wed 22/02/06
```

Use the encoder to select the correct Hour, press the "→" and set the correct minute, then repeat this process for the Day & Date.



NOTE: After setting the Time / Date it is necessary to PRESS the encoder to force the unit to accept the changes.

6.2 TEXT ENTRY (INSTALLATION NAME & SERVICE INFORMATION)

Figure 6.2 — Text Entry Menu Location

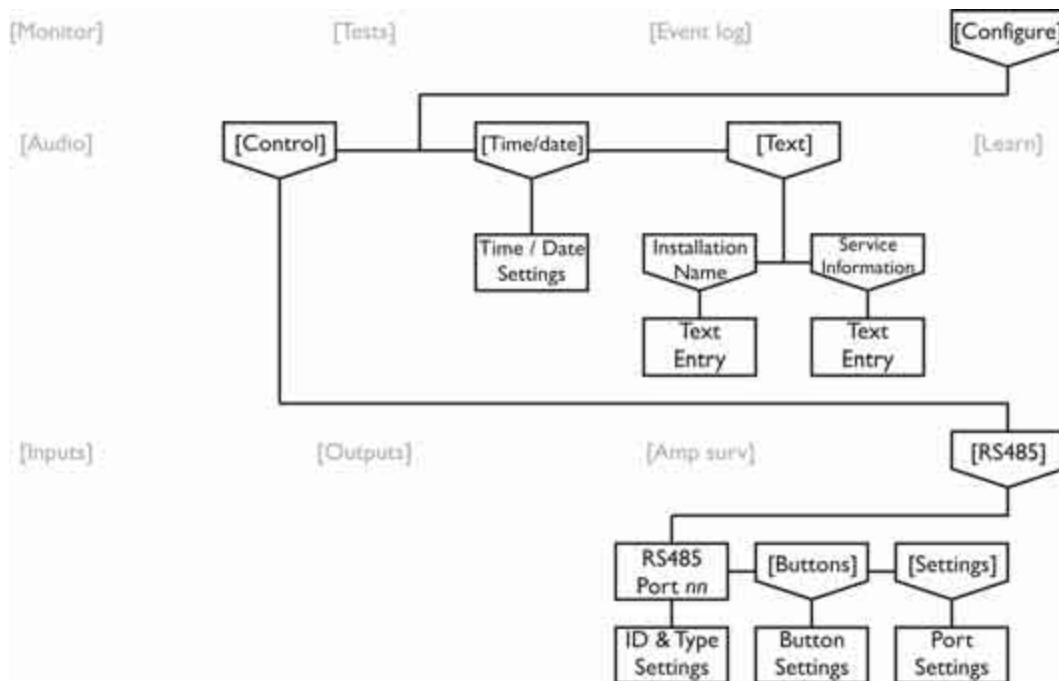

Navigate to the Configuration Menu.

```

Configuration
[Audio] [Control] [Time/date] [Text] [Learn]
  
```

Select Text to open the Text Entry menu.

```

Configuration
[Installation name] [Service information]
  
```

6.2.1 Installation Name Entry

Select Installation to open the Installation Name entry menu.

```

Configuration
[Installation name] [Service information]
  
```

The Installation entry menu will then be displayed.

```

Installation Name:
(           Installation           )      FP v1.262
  
```

Use the Encoder to select the first letter, press "→" to move to the next character, and select the next character using the encoder etc.



NOTE: After setting the Installation Name it is necessary to PRESS the encoder to force the unit to accept the changes.

6.2.2 Service Information Entry

Select Service to open the Service Information entry menu.

```
Configuration
[Installation name] [Service information]
```

The Service Information menu will then be displayed.

```
Configuration
( CONTACT 01892 664422 ) FP v1.262
```

Use the Encoder to select the first letter of the Contact's information, press "→" to move to the next character, then select the next character using the encoder etc.



NOTE: After setting the Contact information it is necessary to PRESS the encoder to force the unit to accept the changes.
