

BVRADC

Operating Instructions

Baldwin Boxall Communications Ltd.
Wealden Industrial Estate, Farningham Road
Crowborough, East Sussex, TN6 2JR
Telephone: 01892 664422
Fax: 01892 663146
Website: www.baldwinboxall.co.uk
Email: mail@baldwinboxall.co.uk

BALDWIN BOXALL
COMMUNICATIONS

VIGIL BVRADC

Description of unit

The Vigil BVRADC is loudspeaker line monitor and amplifier changeover unit, for use with VIGIL series amplifiers and the BVR20 or BVRD2M routers

Each unit is supplied as a DIN rail-mounting module, with screw terminals for connections to the amplifiers and loudspeaker lines. Connection to the BVR20 is via the ribbon cable assembly, or to the BVRD2M by the CAN BUS ports.

Amplifier changeover function

Each unit consists of ten channels that can be utilised for either dual or single circuit systems. For dual circuits ten working amplifiers (five dual circuits) and one standby amplifier can be accommodated, for single circuits this is reduced to five working amplifiers and one standby amplifier.

If an amplifier were to fail the BVRADC automatically detects the faulty amplifier and switches over to a reserve amplifier until the fault has been rectified. A fault will be displayed on the BVR20 front panel.

Loudspeaker line monitor function

The Vigil BVRADC can monitor a maximum of forty loudspeakers, the unit will detect the individual removal of up to seven loudspeakers.

The integrity of the loudspeaker circuit wiring is continuously monitored by a constant voltage source, each loudspeaker is fitted with a DC blocking capacitor and an end of line (EOL) resistor. The removal of any loudspeaker is detected as a change in current by the BVRADC, open or short circuits, and earth faults are also detected.

All loudspeakers must be fitted with the correct components as shown in the following table and Figure 1.

Component	Description	Value
Capacitor	None Polarised	2.2MF 250V
Resistor	High Stability	10K 2W 1%

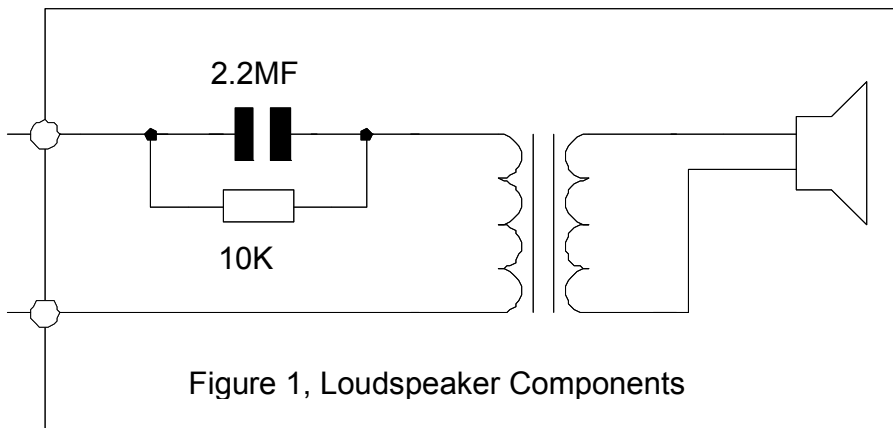

BVADC Installation Procedure

Calibration

- 1 Ensure all individual loudspeakers are fitted with the correct monitoring components, that they are operating correctly, and and tapped to produce the required maximum sound level.
- 2 Disconnect the individual loudspeaker line(s) from the BVADC module.
- 3 Using an impedance meter set to 1kHz, measure and record the impedance. Ensure the load does not exceed the amplifiers rating.
- 4 Using a digital multi meter, measure and record the DC resistance. Divide this value into 10,000 and ensure the result equals the number of speakers connected.
- 5 Reconnect the line to the appropriate output terminals on the BVADC module.
- 6 Repeat steps 1 to 4 for all lines to be connected to the BVADC module.
- 7 Select SW1 switch 5&6 to 'ON' and press the Calibrate switch to set the calibrate reference for all 10 lines. Return SW1 switch 6 to 'OFF' to enable normal operation.

To calibrate an individual line select the required line using SW1 as shown below and pressing the calibrate switch:

After calibrating set SW1 to the required address, ensure switch 6 is off.

SW1						Line
6	5	4	3	2	1	
1	0	0	0	0	1	1
1	0	0	0	1	0	2
1	0	0	0	1	1	3
1	0	0	1	0	0	4
1	0	0	1	0	1	5
1	0	0	1	1	0	6
1	0	0	1	1	1	7
1	0	1	0	0	0	8
1	0	1	0	0	1	9
1	0	1	0	1	0	10
1	1	X	X	X	X	All lines

Set Address

To enable BVRADC module to communicate with the host via the RS485 connection it requires a unique address to be set using SW1 for normal operation as shown below.

Note: Ensure that SW1 switch 6 is 'OFF'.

SW1						Address
6	5	4	3	2	1	
0	0	0	0	0	0	0
0	0	0	0	0	1	1
0	0	0	0	1	0	2
0	0	0	0	1	1	3
0	0	0	1	0	0	4
0	0	0	1	0	1	5
0	0	0	1	1	0	6
0	0	0	1	1	1	7
0	0	1	0	0	0	8
0	0	1	0	0	1	9
0	0	1	0	1	0	10
0	0	1	0	1	1	11
0	0	1	1	0	0	12
0	0	1	1	0	1	13
0	0	1	1	1	0	14
0	0	1	1	1	0	15

SW1						Address
6	5	4	3	2	1	
0	1	0	0	0	0	16
0	1	0	0	0	1	17
0	1	0	0	1	0	18
0	1	0	0	1	1	19
0	1	0	1	0	0	20
0	1	0	1	0	1	21
0	1	0	1	1	0	22
0	1	0	1	1	1	23
0	1	1	0	0	0	24
0	1	1	0	0	1	25
0	1	1	0	1	0	26
0	1	1	0	1	1	27
0	1	1	1	0	0	28
0	1	1	1	0	1	29
0	1	1	1	1	0	30
0	1	1	1	1	1	31

Detail of BVRADC Module

