

IBVR20  
24/01/2006  
ECR 1682

## VIGIL BVR20 - *Microdrive*

*(For use with software issue BVR8.44)*

# SETUP INSTRUCTIONS

**Baldwin Boxall Communications Ltd.**

Wealden Industrial Estate, Farningham Road  
Crowborough, East Sussex, TN6 2JR

Telephone: 01892 664422 Fax: 01892 663146

Website: [www.baldwinboxall.co.uk](http://www.baldwinboxall.co.uk)

Email: [mail@baldwinboxall.co.uk](mailto:mail@baldwinboxall.co.uk)

**BALDWIN BOX▲LL**  
COMMUNICATIONS

## CONTENTS

VIGIL BVR20 MICRODRIVE .....	3
BVR802 – Quad EPROM based digital message module .....	4
BVR20 FRONT PANEL CONTROLS AND INDICATORS .....	5
DESCRIPTION OF FRONT PANEL CONTROLS AND INDICATORS.....	6
MAINTENANCE OF THE BVR20.....	7
FAULT REPORTING AND STATUS PAGES .....	8
HOW TO MONITOR EITHER AN INPUT OR OUTPUT CHANNEL SIGNAL.....	11
HOW TO VIEW OR CHANGE AN OUTPUT CHANNEL SETTING.....	12
HOW TO VIEW OR CHANGE AN INPUT CHANNEL SETTING.....	16
HOW TO VIEW OR CHANGE SERIAL PORT ADDRESS, BVRM ZONE POSITION, FIRE PANEL INTERFACE SELECTION AND MESSAGE CONFIGURATION.....	20
CODES FOR ZONE OUTPUT BARRING .....	23
BVRM DIL SWITCH SETTINGS.....	36
BVR20 PAGE STRUCTURE (Pages 1-120) .....	37
BVR20 PAGE STRUCTURE (Pages 121-304) .....	38
Software Versions & Release Notes .....	39
BVRAMB Ambient Noise Supplement.....	40



Low Voltage Directive  
73/23/EEC as amended  
by 93/68/EEC

EMC Directive  
89/336/EEC as amended  
by 92/31/EEC and 93/68/EEC

Applies only when the items  
are correctly fitted and operated  
in or with products of our  
manufacture and are installed  
in a recommended enclosure

## **VIGIL BVR20 MICRODRIVE**

The BVR20 (*Microdrive*) is the heart of the Voice Alarm system that accepts all of the audio inputs and provides the outputs for the whole voice alarm system. Up to 20 audio inputs can be routed through to up to 20 outputs (zones) in any configuration. The inputs range from any microphone or line level source to the emergency messages and background music. The system is modular, and depending on the system requirements different modules are plugged into the rear of the BVR20.

### **BVR20 Modules & Brief description of Functions and Features**

Module	Function
BVRCPU	CPU and PSU card: one per BVR20
BVRI4	Quad line input (each with attenuator, compressor, limiter, 5 band equ & chime control)
BVR802	Quad Digital message card, accepts up to 4 OPT402 modules
BVRO2	Dual line output card (each with 6 band equ and option socket for further EQ module)
BVRIO40	40 parallel inputs for zonal access, monitoring, fault i/p & o/p, changeover etc
BVRACO	Control interface for faulty amplifier changeover
BVRNCO	Control interface for when automatic changeover is not required
BVRCI	Control interface for universal zonal access switching, with Ambient noise option
BVRAIO	Control interface for Fire Alarm Panel
BVRL20	20 way 3 metre ribbon cable for connecting cards and interface modules
BVRL26	26 way 3 metre ribbon cable for connecting cards and interface modules

The BVR20 provides all of the monitoring functions and displays the system status using a 40 x 2 character LCD display and 5 front panel mounted LEDs.

The unit can be operated in two separate modes depending on the position of the front panel key-switch. Under 'Normal' operating conditions (i.e. the key is not turned) all advanced functions of the BVR20 are barred to prevent unauthorised changes to the system. The only options available are monitoring input and output signals through the internal loudspeaker, and viewing the system status pages which can be scrolled up or down to display the status of the monitored items in the Voice Alarm system.

If the 'System Configuration' key-switch is turned the unit is in System Configuration mode and all functions of the BVR20 can be changed.

***The functionality of the Voice Alarm System can be altered in this mode. As incorrect use of this mode could prevent an Alarm Condition from being detected we strongly suggest that this mode is not entered unless the user is fully aware of the system configuration.***

If changes are to be made in this mode please refer to the relevant pages of this manual on how to achieve the changes required.

To discourage leaving the unit in "System Configuration" mode the key cannot be removed from the switch until it is returned to the "Normal" position.

When the unit is first powered up, various settings and controls will require setting up in the "Configuration" Mode. Once these have been set, the internal memory will hold this information. Should mains and/or battery power loss occur the settings will remain in the memory.

## BVR802 – Quad EPROM based digital message module

This card enables four OPT 402 message modules to be fitted allowing up to seven messages to be stored on one card. It has the following features:-

- Three dual messages plus one single message – 7 x 32 seconds in length or four at 64 seconds.
- Each message has output attenuation.
- Bass, Treble and two mid band controls @ 1KHz & 2.5KHz.
- 200Hz 12dB/Octave high pass filter.
- Aural and visual monitor.
- 20 sounder circuit opto-coupled inputs.

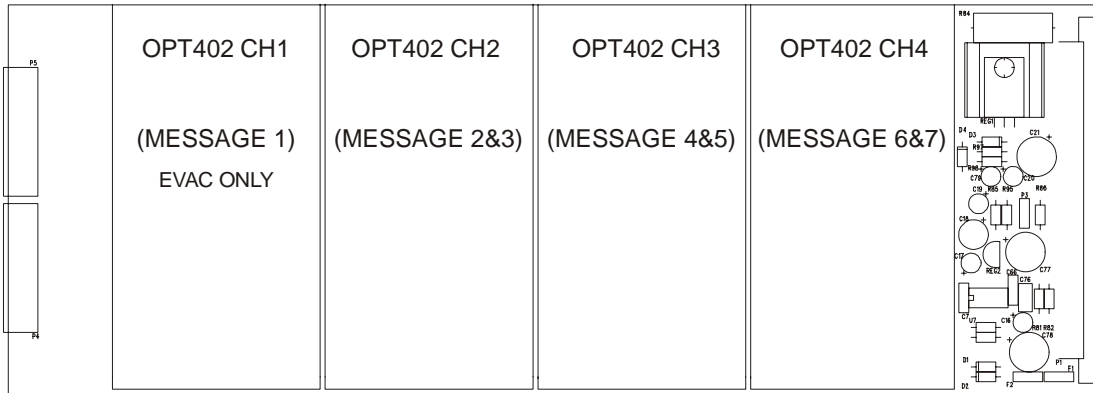

### OPT402 Positions on BVR802

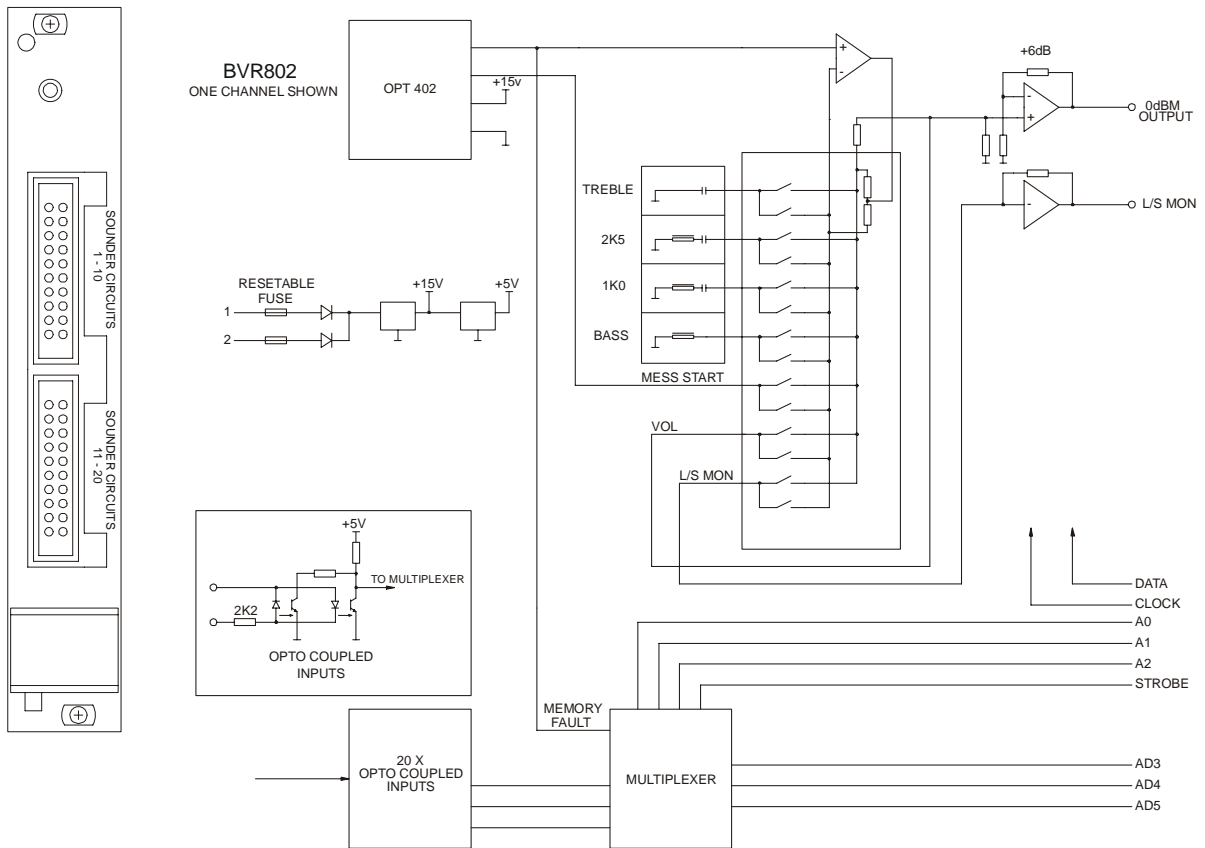

# BVR20 FRONT PANEL CONTROLS AND INDICATORS

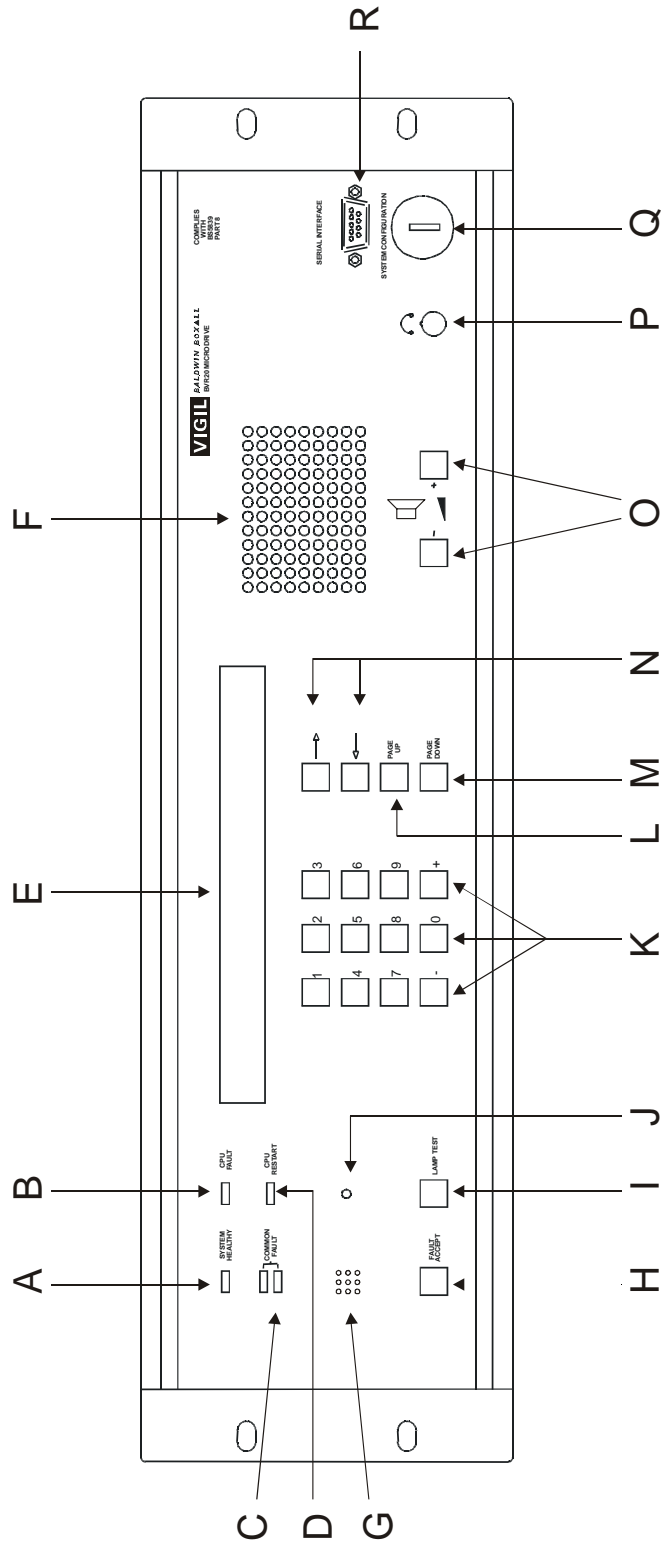

## DESCRIPTION OF FRONT PANEL CONTROLS AND INDICATORS

A	'System Healthy' LED	Will illuminate when no faults are detected.
B	'CPU Fault' LED	If illuminated a critical CPU failure has occurred. Only Fire Mic 1 'All Call' function will operate as this input bypasses all CPU control as required by BS5839 pt 8.
C	'Common Fault' LEDs	Will flash and a buzzer will sound when a Fault is detected until "Fault Accept" button (H) is pressed. After a fault is accepted the buzzer is silenced and the LEDs remain illuminated until the fault is cleared.
D	CPU Restart LED	Will illuminate when CPU Restart (J) button needs to be pressed. This will occur when the unit is powered up for the first time, but should extinguish after the restart. Required by BS5839 pt 8.
E	40 x 2 LCD Display	Main display where system status and setup configuration is shown.
F	Loudspeaker	Loudspeaker for monitoring input and output signals.
G	Buzzer	Sounds when a fault is detected, see (C) for more details.
H	'Fault Accept' Button	Press to accept a fault once detected, see (C) for more details.
I	'Lamp Test' Button	Press to check front panel LED and buzzer operation. Note: if the system is in a fault condition the green 'System Healthy' LED will not illuminate on a lamp test.
J	CPU Restart Button	Recessed button that enables the CPU to be restarted, see (D) for more details.
K	Data Entry Keypad	Numerical keys for entering and changing data.
L & M	'Page Up' / 'Page Down' Buttons	Press to scroll through Status Pages displayed on the LCD Display.
N	'←' & '→' Buttons	Press to navigate cursor inside Status Pages.
O	Volume Control	Press to alter volume of monitor Loudspeaker or Headphones.
P	Headphone Socket	Socket for Headphones to monitor input and output signals. If Headphones are connected the internal loudspeaker is muted.
Q	'System Configuration' Keyswitch	Key-switch to enable System Configuration. When enabled all functions of the BVR20 can be modified. The key cannot be removed in the 'System Configuration' position.
R	'Serial Interface'	Feature not available on this software release.

## **MAINTENANCE OF THE BVR20**

If a fault is suspected on any of the BVR20 modules, simple substitution with a spare can be carried out as first-line maintenance. Before removing any module ensure that the two DC supplies are disconnected by removing the lower 8-way blue plug from the CPU module. The CPU module BVRCPU – as viewed from the rear – is located at the extreme right hand side, position 21.

Carefully remove all connectors to the suspected module with a small posi-drive screwdriver, release the two retaining screws at the rear of the module and, observing electro-static precautions, carefully remove the module. To replace the module, carefully slide in the new module, fasten it using the two screws, replace the connectors and now you are ready to apply power. Please ensure that the correct module has been fitted in the correct position.

The heart of the BVR20 is the CPU module – BVRCPU - which controls all the input and output routing, together with all monitoring facilities. Please note this module must only be fitted in position 21, at the extreme right hand side of the BVR20.

As a simple guide to fault finding, should one zone output be faulty then it would be true to suspect the output card serving that zone – especially if the other channel is operating.

Input modules – BVR14 - have four inputs, each with a max sensitivity of -20dBm ( $\approx 80\text{mV}$ ), which is amplified and presented to the audio bus structure at 0 dBm ( $\approx 800\text{mV}$ ).

The message module –BVR802 – has the facility for four messages and provides 20 opto isolated inputs to interface with fire detection panel sounder circuits. Again the signal from each message is presented to the audio bus at 0dBm. The system monitors the audio output presented to the first output module and the DC bias present at the output of the digital-to-analogue converter, which is displayed as a memory fault.

The dual output card –BVR02 – has two line outputs of 0dBm and provides frequency equalisation and gating from all the 20 input signals. This module also provides volt-free relay contacts, which change condition when the zone is busy.

On the system there are two signal input/output cards – the BVRIO40 which, in conjunction with the interface cards – the BVRACO, monitor the external loudspeaker lines using the BEL1 end of line units. The BVRACO also provides automatic changeover in the event of a faulty amplifier to a reserve. The module positioned in P18 serves all the ‘A’ circuits, whilst the one fitted to P19 serves all the ‘B’ circuits. Input signals for the reserve amplifiers are obtained from output modules plugged into P16 and P17 and automatically, in the event of an amplifier failure, route the correct source of signals to the relevant reserve amplifier.

All of the BVR20 modules are fed from an unregulated dual supply line and regulation is provided on each module. The supply input to each card is protected by a poly-switch self-resettable fuse and, in the case of the CPU, a dual regulator path is provided.

**Please note: Under no circumstances remove or replace a module with the power supply connected.**

Should a faulty module be discovered, repair can only be accomplished in an equipped workshop. Therefore, we recommend that first-line maintenance is carried out by replacing modules from a spares stock.

***If the system has automatic changeover it will be necessary to press the ‘CPU Restart’ on front panel when the faulty amplifier is replaced.***

## FAULT REPORTING AND STATUS PAGES

(Available in "normal" mode i.e. without turning the "system configuration" key.)

In normal operation mode this unit indicates the condition of the system via the front panel display. Under normal - i.e. **non**-fault - conditions the green healthy indicator will illuminate, the fault relay will be energised and the sounder will be silent.

A fault is indicated by the flashing yellow "Common Fault" indicators, together with the sounder, sounding 1 second on, 1 second off. By pressing the "Fault Accept" button the fault indicator will illuminate continuously and the sounder will be silent. Separate yellow indicators are used for CPU Fault and CPU Restart. Pressing the "Lamp Test" button checks all the "Fault" indicators.

**Note: Operation of the "Fault Accept" button does not affect the fault output produced by the relay contacts to external equipment i.e. Fire detection panel.**

The various status pages are scrolled up and down with the "Page Up" and "Page Down" keys.

Faults are shown by "XX" in place of "OK", lower case "ok" shows a fault has occurred and cleared. This is useful to show where intermittent faults have been, to reset operate key switch momentarily.

The pages are displayed in the following order:

Page1. Loudspeaker lines 1-10 circuit A.

```
-----  
| L/S LINE A | 01 | 02 | 03 | 04 | 05 | 06 | 07 | 08 | 09 | 10 |  
|   FAULTS   | XX | OK | OK | OK | OK | OK | OK | OK | OK |  
-----
```

E.g. XX indicates there is a fault on loudspeaker circuit 1A.

Page2. Loudspeaker lines 1-10 circuit B.

```
-----  
| L/S LINE B | 01 | 02 | 03 | 04 | 05 | 06 | 07 | 08 | 09 | 10 |  
| NO FAULTS  | OK | OK | OK | OK | OK | OK | OK | OK | OK |  
-----
```

Page3. Loudspeaker lines 11-20 circuit A.

```
-----  
| L/S LINE A | 11 | 12 | 13 | 14 | 15 | 16 | 17 | 18 | 19 | 20 |  
| NO FAULTS  | OK | OK | OK | OK | OK | OK | OK | OK | OK |  
-----
```

Page4. Loudspeaker lines 11-20 circuit B.

```
-----  
| L/S LINE B | 11 | 12 | 13 | 14 | 15 | 16 | 17 | 18 | 19 | 20 |  
| NO FAULTS  | OK | OK | OK | OK | OK | OK | OK | OK | OK |  
-----
```

Page5. Reserve amplifiers.

```
-----  
| RESERVE   AMPLIFIERS | 1 OK | 2 OK | 3 OK | 4 OK |  
| NO FAULTS           | In use | - -- | - -- | - -- |  
-----
```

Page 5 examples.

```
-----  
| RESERVE   AMPLIFIERS | 1 XX | 2 OK | 3 OK | 4 OK |  
|   FAULTS         In use | -  -- | -  -- | -  -- | -  -- |  
-----
```

XX indicates that reserve amplifier 1 has a fault.

```
-----  
| RESERVE   AMPLIFIERS | 1 OK | 2 OK | 3 OK | 4 OK |  
| NO FAULTS         In use | A 01 | -  -- | -  -- | -  -- |  
-----
```

Reserve amplifier 1 in use on loudspeaker circuit 1A.

Page6. Emergency microphones.

```
-----  
| FIRE MICS | AUDIO 1=OK | ACCESS 1=OK |  
| NO FAULTS | 2=OK 3=OK 4=OK | 2=OK 3=OK 4=OK |  
-----
```

Emergency microphones

```
-----  
| FIRE MICS | AUDIO 1=OK | ACCESS 1=OK |  
|   FAULTS | 2=XX 3=OK 4=OK | 2=OK 3=OK 4=OK |  
-----
```

XX indicates that Mic 2 has an audio fault

Page7. Message 1 (evacuate).

```
-----  
| MESSAGE 1   EVACUATE | MEMORY | AUDIO | ACCESS |  
| NO FAULTS           | OK     | OK   | OK     |  
-----
```

Page8. Message 2 and 3.

```
-----  
| MESSAGE 2 & 3 | MEMORY | AUDIO | ACCESS |  
| NO FAULTS     | OK     | OK   | 2=OK 3=OK |  
-----
```

Page9. Message 4 and 5.

```
-----  
| MESSAGE 4 & 5 | MEMORY | AUDIO | ACCESS |  
| NO FAULTS     | OK     | OK   | 4=OK 5=OK |  
-----
```

Page10. Message 6 and 7.

```
-----  
| MESSAGE 6 & 7 | MEMORY | AUDIO | ACCESS |  
| NO FAULTS     | OK     | OK   | 6=OK 7=OK |  
-----
```

Page11. Page microphones 1 to 4 if monitored.

```
-----  
| PAGE MICS | AUDIO 1=OK | ACCESS 1=OK |  
| NO FAULTS | 2=OK 3=OK 4=OK | 2=OK 3=OK 4=OK |  
-----
```

Page microphones 1 to 4

```
-----  
| PAGE MICS | AUDIO 1=OK | ACCESS 1=OK |  
| FAULTS | 2=XX 3=OK 4=OK | 2=OK 3=OK 4=OK |  
-----
```

XX indicates that Mic 2 has a audio fault.

Page12. Page microphones 5 to 8 if monitored.

```
-----  
| PAGE MICS | AUDIO 5=OK | ACCESS 5=OK |  
| NO FAULTS | 6=OK 7=OK 8=OK | 6=OK 7=OK 8=OK |  
-----
```

Page microphones

```
-----  
| PAGE MICS | AUDIO 5=OK | ACCESS 5=OK |  
| FAULTS | 6=OK 7=OK 8=OK | 6=OK 7=XX 8=OK |  
-----
```

XX indicates that Mic7 has a access fault.

Page13. Noise sensing microphones 1 to 10

```
-----  
| NOISE SENS | 01 | 02 | 03 | 04 | 05 | 06 | 07 | 08 | 09 | 10 |  
| NO FAULTS | OK | OK | OK | OK | OK | OK | OK | OK | OK | OK |  
-----
```

Page14. Noise sensing microphones 11 to 20

```
-----  
| NOISE SENS | 11 | 12 | 13 | 14 | 15 | 16 | 17 | 18 | 19 | 20 |  
| NO FAULTS | OK | OK | OK | OK | OK | OK | OK | OK | OK | OK |  
-----
```

Page15. Power supplies to BVR 20 and battery chargers

```
-----  
| POWER | BATT/CHARGER | SUPPLY 1 | SUPPLY 2 |  
| NO FAULTS | OK | OK | OK |  
-----
```

Page16.

```
-----  
| L/S | OUTPUT ZONE | INPUT SOURCE | VOLUME |  
| MONITOR | 00 | -- | 00 |  
-----
```

**HOW TO MONITOR EITHER AN INPUT OR OUTPUT CHANNEL SIGNAL**  
**VIA THE INTERNAL LOUDSPEAKER**

Use the “Page Up” or “Page Down” keys to select the page shown below.

```
-----  
|   L/S   | OUTPUT ZONE | INPUT SOURCE | VOLUME |  
| MONITOR | 00         | --         | 00     |  
-----
```

Press the “→” or “←” cursor keys and move along to the INPUT SOURCE or OUTPUT ZONE window.

Using the + or – keys enter the No. of the input or output required .

Adjust the Internal Speaker volume or Headphone output by using the Volume Control + and – keys to set the required level.

## HOW TO VIEW OR CHANGE AN OUTPUT CHANNEL SETTING.

1. Insert the key and rotate clockwise.

The display will show the software version, in this example 08.44.

```
-----  
| BVR 20 VOICE ALARM Version 08.44 06.19 |  
| BALDWIN BOXALL COMMUNICATIONS |  
-----
```

2. Press the Page down key.

The display invites you to enter your 4 digit access code to enable adjustments.

There are 4 access levels.

Level 1 allows input and output equalizer, volume, limiter/compressor and chime volume adjustments only.

Level 2 allows level 1 together with amplifier/loudspeaker line surveillance and ambient noise adjustments.

Level 3 allows level 2 and all other settings except access level codes.

Level 4 allows level 3 and access level codes.

```
-----  
| *****WARNING***** |  
| ENTER CODE TO ENABLE ADJUSTMENTS   ??? |  
-----
```

3. Enter your 4 digit access code, the factory set default for all levels is 0000, but may be changed via level 4.

Press the Page down key again.

The display invites you to enter an output channel number 1-20 that you wish to set up.

```
-----  
| OUT 00 VOLUME & EQUALIZER SETTINGS |  
| Enter output no required Press page down |  
-----
```

4. Enter the output channel number required using the numbered keys.

(If you are selecting an input channel between 1 and 9, please remember to include a 0 before the output channel number, i.e. '01').

```
-----  
| OUT 01 VOLUME & EQUALIZER SETTINGS |  
| Enter output no required Press page down |  
-----
```

5. Press the Page down key again.

The display will step to the 1<sup>st</sup> page, current input volume levels 1-10 of output channel 1.

```
-----  
| OUT 01 in|01|02|03|04|05|06|07|08|09|10 |  
| volume|00|00|00|00|00|00|00|00|00|00 |  
-----
```

**Note:**

Surveillance for inputs 1-9 is sampled from output 1 and therefore associated inputs on output 1 must be set to a value greater than 05 to prevent input audio faults.

Surveillance for inputs 10-16 is sampled from outputs 2-8 respectfully, i.e. input 10 from output 2, input 16 from output 8 and therefore the associated inputs on the relevant outputs must be set to a value greater than 05 to prevent input audio faults.

Each output channel has an independent adjustment for the volume level from each input channel.

- To select the input volume level to adjust, move the cursor along using the arrow keys until it flashes beneath the input window required. Values between 0-9 may be entered directly using the numbered keys, note the cursor automatically steps to the next input. Or using the + or – keys will increase or decrease the value between 00 (silent) and 15 (maximum).
- Press the Page down key again.  
The display will step to the 2<sup>nd</sup> page, current input volume levels 11-20 of output channel 1.

```
-----  
|  OUT 01  in|11|12|13|14|15|16|17|18|19|20 |  
|           volume|00|00|00|00|00|00|00|00|00|00 |  
-----
```

The levels are adjusted as before, please refer to 6.

- Press the Page down key again.  
The display will step to the 3<sup>rd</sup> page, current equalizer settings of output channel 1.

```
-----  
|  OUT 01 frequency|315|500|1K0|2K0|3K1|6K3 |  
|           equalizer(dB)|+12|-12|+06|-06|+02|-02 |  
-----
```

To select the frequency to adjust, move the cursor along using the arrow keys until it flashes beneath the frequency window required. If you wish to set the value to 0 (flat), simply press the 0 key, note the cursor automatically steps to the next frequency setting. Or using the + or – keys will lift or cut the value between +14 and -14.

- Press the Page down key again.  
The display will show the 4<sup>th</sup> page, current chime, surveillance and sensor settings.

```
-----  
|  OUT 01|CHIME|SURV   (A=00 B=00)|ANS (-00 |  
|           |   00|Out 00|Off           |Sens  00 |  
-----
```



To adjust the chime volume. Ensure the cursor is flashing beneath the chime volume window. Values between 0-9 may be entered directly using the numbered keys, note the cursor automatically steps to the surveillance out level setting. Or using the + or – keys will increase or decrease the value between 00 (silent) and 15 (maximum).

Note: Under normal operating conditions the loudspeaker line surveillance signal is pulsed 1 second on in every 30 seconds. This allows the fault to be announced within 100 seconds to conform to BS5839 Pt 8. When the above page (P4) is selected, the surveillance signal is continuous to enable output level setting.

```

-----
| OUT 01 | CHIME | SURV   (A=00 B=00) | ANS (-00 |
|         |         | 00 | Out 00 | Off           | Sens  00 |
-----

```

↑

To select surveillance, move the cursor along until it flashes beneath the surveillance out window shown above.

If surveillance is not required press 0 and the display will show 00.

If surveillance is required press 9 and the display will show 09.

The loudspeaker lines must be terminated with end of line units BEL1.

```

-----
| OUT 01 | CHIME | SURV   (A=00 B=00) | ANS (-00 |
|         |         | 00 | Out 09 | Off           | Sens  00 |
-----

```

↑

Move the cursor along using the arrow keys until it flashes beneath the surveillance frequency window.

If surveillance is not required press 0 and the display will show Off. This will disable the associated loudspeaker line faults.

If surveillance is required press and release the + key until you have selected the required frequency and mode.

Note for normal surveillance operation only use 30Hz or 20KHz.

Example 1: Frequency 30Hz, loudspeaker line A monitored only

```

-----
| OUT 01 | CHIME | SURV   (A=00 B=00) | ANS (-00 |
|         |         | 00 | Out 09 | 30Hz A       | Sens  00 |
-----

```

Example 2: Frequency 20KHz, loudspeaker lines A and B monitored.

```

-----
| OUT 01 | CHIME | SURV   (A=00 B=00) | ANS (-00 |
|         |         | 00 | Out 09 | 20K A+B     | Sens  00 |
-----

```

Example 3: Frequency 20KHz, loudspeaker line A and reserve amplifier monitored.

```

-----
| OUT 01 | CHIME | SURV   (A=00 B=00) | ANS (-00 |
|         |         | 00 | Out 09 | 20K A+Res   | Sens  00 |
-----

```

Example 4: Frequency 20KHz, loudspeaker line A, line B and reserve amplifier monitored. A&B return signals.

```

-----
| OUT 01 | CHIME | SURV   (A=09 B=09) | ANS (-00 |
|         |         | 00 | Out 09 | 20K A+B+Res | Sens  00 |
-----

```

↑

If surveillance is selected, move the cursor along until it flashes beneath the surveillance out window. Adjust the level using the + or – keys so that A and B BEL1 return signals =09, this is the typical return value for a 10 Volt loudspeaker line surveillance signal. If you have difficulty in obtaining a return signal of 09, please check the loudspeaker line.

Ambient noise sensor, only available outputs 1-16.  
 Volume reduction factor ( -12 minimum output), (--00 maximum output).

```

                                     ↓
-----
|  OUT 01 | CHIME | SURV   (A=00 B=00) | ANS (-00 |
|          |      00 | Out 09 | 20K A+B+Res | Sens  00 |
-----
                                     ↑
  
```

Move the cursor along until it flashes beneath the sensor window, shown above.  
 If ambient noise sensing is not required or the maximum output is being set, press 0 to disable it. This will also prevent the associated sensor fault being announced.

When the maximum levels have been set, using the + key slowly increase the value until the loudspeaker level follows the ambient noise.  
 In theory, if the ambient noise is at its loudest, the announcements should remain around 10dB above the ambient level. The sensitivity is adjustable from 01 and 15. Once set, the loudspeaker volume will automatically adjust to the ambient noise in that zone, from maximum and 20dB below maximum. Therefore if the sensor does not sense a signal, the output will be 20dB below the maximum setting.

Pressing the Page up key enables you to step to the previous page.  
 Pressing the Page down key enables you to step to the next page, in this example Output 2 page 1.

```

-----
|  OUT 02  in | 01 | 02 | 03 | 04 | 05 | 06 | 07 | 08 | 09 | 10 |
|          volume | 00 | 00 | 00 | 00 | 00 | 00 | 00 | 00 | 00 | 00 |
-----
  
```

Note: Once settings have been adjusted, always return the key to the anti clockwise position to prevent accidental adjustment.

## HOW TO VIEW OR CHANGE AN INPUT CHANNEL SETTING.

1. Insert the key and rotate clockwise.

The display will show the software version, in this example 08.44.

```
-----  
| BVR 20 VOICE ALARM Version 08.44 06.19 |  
| BALDWIN BOXALL COMMUNICATIONS |  
-----
```

2. Press the Page down key.

The display invites you to enter your 4 digit access code to enable adjustments.

There are 4 access levels,

Level 1 allows input and output equalizer, volume, limiter/compressor and chime volume adjustments only.

Level 2 allows level 1 together with amplifier/loudspeaker line surveillance and ambient noise adjustments.

Level 3 allows level 2 and all other settings except access level codes.

Level 4 allows level 3 and access level codes.

```
-----  
| *****WARNING***** |  
| ENTER CODE TO ENABLE ADJUSTMENTS   ??? |  
-----
```

3. Enter your 4 digit access code, the factory set default for all levels is 0000, but may be changed via level 4.

Press the Page down key again.

The display invites you to enter an output channel number 1-20 that you wish to set up.

```
-----  
| OUT 00 VOLUME & EQUALIZER SETTINGS |  
| Enter output no required Press page down |  
-----
```

4. Press the Page down key again.

The display invites you to enter an input channel number 1-20 that you wish to set up.

```
-----  
| IN 00 VOLUME & EQUALIZER SETTINGS |  
| Enter input no required Press page down |  
-----
```

5. Enter the input channel number required using the numbered keys.

(If you are selecting an input channel between 1 and 9, please remember to include a 0 before the output channel number, i.e. '08').

```
-----  
| IN 08 VOLUME & EQUALIZER SETTINGS |  
| Enter input no required Press page down |  
-----
```

6. Press the Page down key again.

The display will step to the 1<sup>st</sup> page, current volume and EQUALIZER settings of input channel 08

```

-----
| IN  08 | VOL | HP | BASS | 600 | 1K0 | 2K5 | TREB | MODE |
|         | 00 | 00 | +12 | -12 | +06 | -06 | +12 |  00 |
-----

```

To adjust the volume. Ensure the cursor is flashing beneath the VOL window. Values between 0-9 may be entered directly using the numbered keys, note the cursor automatically steps to the HP window. Or using the + or – keys will increase or decrease the value between 00 (minimum -12db) and 15 (maximum 0dB).

To adjust the 200Hz high pass filter. Move the cursor along until it flashes beneath the HP setting.

Values between 0-9 may be entered directly using the numbered keys, note the cursor automatically steps to the BASS window. Or using the + or – keys will increase or decrease the value between 00 (filter in, 12dB/oct) and 15 (filter out).

To adjust the 5 band equalizer. Move the cursor along until it flashes beneath the frequency required. If you wish to set the value to 0 (flat), simply press the 0 key, note the cursor automatically steps to the next window. Or using the + or – keys will lift or cut the value between +14 and –14.

Input surveillance and busy relay output.

```

-----
| IN  08 | VOL | HP | BASS | 600 | 1K0 | 2K5 | TREB | MODE |
|         | 00 | 00 | +12 | -12 | +06 | -06 | +12 |  00 |
-----

```

↑

Mode 00 Input surveillance off. Busy output off.

Mode 01 Input surveillance on. Busy output off.

Mode 02 Input surveillance off. Busy output on.

Mode 03 Input surveillance on. Busy output on.

If this input channel is used for an emergency message or microphone the signal path should be under surveillance and mode 01 or 03 should be used. This will enable associated input channel faults. Available on inputs 01-16 only.

Each output channel has a volt free change over relay contact that may be used to operate external busy indicators but is only active when modes 02 or 03 are selected.

To set the mode. Move the cursor along until it flashes beneath the MODE window and using the numbered keys enter your choice 0 to 3.

Press the Page down key again.

The display will step to the 2<sup>nd</sup> page, current attenuator compressor and chime settings for input channel 08.

```

-----
| IN  08 | ATTENUATOR | COMPRESSOR | CHIME |
|         | .00 | . . . . 00 | Off   | Off   |
-----
| fine | coarse |

```

The maximum input sensitivity without attenuation is 80mV (-20dBm). However the gain may be reduced using a fine and coarse attenuator. The fine provides 15dB of attenuation in approximately 1dB steps and the coarse provides 30 dB in 2dB steps. Setting the attenuator correctly will prevent overloading the input stage and easier adjustment of the system. If an input of 775mV (0dBm) is required than simply attenuate the input by 20dB by setting the coarse to 09.

To set the input attenuator, move the cursor along until it flashes beneath the desired attenuator window. Values between 0-9 may be entered directly using the numbered keys. Note the cursor automatically steps to the next window. Or using the + or – keys will increase or decrease the value between 00 (no attenuation) and 15 (maximum attenuation)

Input dynamic compressor or limiter may be introduced to prevent overloading and assists in maintaining a constant output volume if several operators use a microphone or music with wide ranging levels..

```

-----
| IN  08|ATTENUATOR|   COMPRESSOR   |CHIME |
|       |.00|. . . .00|Off       |Off   |
-----

```



To select either a limiter or compressor, move the cursor along until it flashes beneath the above window. If no limiter or compressor is required, press 0 , the display will indicate Off.

If a limiter action is required, press 1. The display will respond thus.

```

-----
| IN  08|ATTENUATOR|   COMPRESSOR   |CHIME |
|       |.00|. . . .00|Limiter  00|Fast|Off |
-----

```

If a compressor action is required, press 2. The display will respond thus.

```

-----
| IN  08|ATTENUATOR|   COMPRESSOR   |CHIME |
|       |.00|. . . .00|Compress 00|Fast|Off |
-----

```



The threshold is adjusted by moving the cursor along until it flashes beneath the above window.

Values between 0-9 may be entered directly using the numbered keys. Note the cursor automatically steps to the next window. Or using the + or – keys will increase or decrease the value between 00 (High threshold) and 15 (Low threshold).

```

-----
| IN  08|ATTENUATOR|   COMPRESSOR   |CHIME |
|       |.00|. . . .00|Limiter  06|Fast|Off |
-----

```



The release time may be either set Fast, ideal for speech or Slow, suitable for music by moving the cursor beneath the above window.

Press 0 to select Fast release, or 1 to select Slow release.

A 1, 2 or 3 note chime may be selected to proceed a live announcement.  
 Move the cursor along until it flashes beneath the chime window.

Press 0 if no chime is required.  
 Press 1 for 1 note.  
 Press 2 for 2 notes.  
 Press 3 for 3 notes.

```

-----
| IN  08 | ATTENUATOR | COMPRESSOR | CHIME |
|        | .00 | ....00 | Limiter 06 | Fast | 3note |
-----
  
```

Pressing Page up key enables you to step to the previous page.  
 Pressing Page down key steps to the next page, in this example Input 09 page 1.

```

-----
| IN  09 | VOL | HP | BASS | 600 | 1K0 | 2K5 | TREB | MODE |
|        | 00 | 00 | +12 | -12 | +06 | -06 | +12 | 00  |
-----
  
```

Note: Once settings have been adjusted, always return the key to the anti clockwise position to prevent accidental adjustment.

### **Listen in Facility**

Listen in is configurable using the chime selection on input 6 and is as follows.

Input 06 CHIME

- |        |   |
|--------|---|
| Off    | No listen in facility. Outputs 18, 19 and 20 may be used as output zones.   |
| 1 note | Only BVRM 1 (input 1) has the listen in facility on output 20. Outputs 18 and 19 may be use as normal output zones.   |
| 2 note | BVRM 1 (input 1) has the listen in facility on output 20. BVRM 2 (input 2) has the listen in facility on output 19. Output 18 may be used as a normal output zone.            |
| 3 note | BVRM 1 (input 1) has the listen in facility on output 20. BVRM 2 (input 2) has the listen in facility on output 19. BVRM 2 (input 3) has the listen in facility on output 18. |

Please ensure that when outputs are used for the listen in facility these outputs are not allocated anywhere in the configuration set up.

### **Note:**

It is also necessary to remove the software bypass all call 2k2 resistors on the output channels modules BVRO2 which are used for the listen in facility as the volume is pre-set and feedback will occur.

Output 20 remove R22 and R24. Output 19 remove R2 and R5.  
 Output 18 remove R22 and R24.

**HOW TO VIEW OR CHANGE SERIAL PORT ADDRESS, BVRM ZONE POSITION, FIRE  
PANEL INTERFACE SELECTION AND MESSAGE CONFIGURATION.**

1. Insert the key and rotate clockwise.  
The display will show the software version, in this example 08.44.

```
-----  
| BVR 20 VOICE ALARM  Version 08.44  06.19 |  
|          BALDWIN BOXALL COMMUNICATIONS |  
-----
```

2. Press the Page down key.  
The display invites you to enter your 4 digit access code to enable adjustments.  
There are 4 access levels,  
Level 1 allows input and output EQUALIZER, volume, limiter/compressor and chime volume adjustments only.  
Level 2 allows level 1 together with amplifier/loudspeaker line surveillance and ambient noise adjustments.  
Level 3 allows level 2 and all other settings except access level codes.  
Level 4 allows level 3 and access level codes.

```
-----  
| *****WARNING***** |  
| ENTER CODE TO ENABLE ADJUSTMENTS   ???? |  
-----
```

3. Enter your 4 digit access code, the factory set default for all levels is 0000, but may be changed via level 4.  
Press the Page down key again.  
The display invites you to enter an output channel number 1-20 that you wish to set up.

```
-----  
| OUT 00  VOLUME & EQUALIZER SETTINGS |  
| Enter output no required Press page down |  
-----
```

4. Press the Page down key again.  
The display invites you to enter an input channel number 1-20 that you wish to set up.

```
-----  
| IN  00  VOLUME & EQUALIZER SETTINGS |  
| Enter input no required Press page down |  
-----
```

5. Press 2.

```
-----  
| IN  20  VOLUME & EQUALIZER SETTINGS |  
| Enter input no required Press page down |  
-----
```

6. Press the Page down key again.  
The display will step to the 1<sup>st</sup> page of input channel 20.

```

-----
| IN  20 |VOL|HP|BASS|600|1K0|2K5|TREB|MODE |
|          |00|00| +12|-12|+06|-06|+12|  00 |
-----

```

7. Press the Page down key again.  
The display will step to the 2<sup>nd</sup> page of input channel 20.

```

-----
| IN  20 |ATTENUATOR|    COMPRESSOR    |CHIME |
|          |.00|...00|Off                |Off   |
-----

```

8. Press the Page down key again.  
The display will step to the 1<sup>st</sup> page of serial port configuration, port address and baud rate.

```

-----
| PORT  TX RX BR MODE | PORT  TX RX BR MODE |
|  1    00 00 00  00 |  2    00 00 00  00 |
-----
          ↑  ↑                ↑  ↑

```

On both ports the TX and RX addresses are independently set. In most applications both the TX and RX are required to be set to the same address. This address only allows data intended for the BVR20 to be processed, thus identifying an individual BVR20 when several (maximum 11) are connected to a BVRM control microphone.

If only 1 BVR20 is connected to a BVRM, the address, both TX and RX is set to 00. If 2 are connected, 1 of the BVR20 is set to 00 and the other is set to 01 and so on for the maximum of 11.

To change an address, move the cursor until it flashes beneath the required window and enter address 0-10.

```

-----
| PORT  TX RX BR MODE | PORT  TX RX BR MODE |
|  1    00 00 00  00 |  2    00 00 00  00 |
-----
                ↑                ↑

```

The 2 off RS 485 half duplex serial ports can communicate to control microphone panels type BVRM or other equipment e.g. fire detection panels. The baud rate, 00=1200, 01=2400, 02=4800, 03=9600, 04= 19200, 05=38400, 06=76800, 07=fast.  
Note: BVRM Default mode is 03.

To change a baud rate, move the cursor until it flashes beneath the required window and enter baud rate 0-7.

```

-----
| PORT  TX RX BR MODE | PORT  TX RX BR MODE |
|  1    00 00 00  00 |  2    00 00 00  00 |
-----
                ↑                ↑

```

The message selection functions from the BVRM microphone may be set using the mode settings on each port, as shown in the following table.

Mode	Message 'Select' and 'Cancel'	Function
00	When all zones are unselected, message select and cancel do not all call / select	Unselected zones will not automatically alert.
01	As above	Message 1 will select all unselected zones to message 2
02	As above	Message 2 will select all unselected zones to message 3
03	As above	Message 3 will select all unselected zones to message 4
04	Select only has an all call function	Unselected zones will not automatically alert
05	As above	Message 1 will select all unselected zones to message 2
06	As above	Message 2 will select all unselected zones to message 3
07	As above	Message 3 will select all unselected zones to message 4
08	Cancel only has an all select function	Unselected zones will not automatically alert
09	As above	Message 1 will select all unselected zones to message 2
10	As above	Message 2 will select all unselected zones to message 3
11	As above	Message 3 will select all unselected zones to message 4
12	Both Select & Cancel have all call / select	Unselected zones will not automatically alert
13	As above	Message 1 will select all unselected zones to message 2
14	As above	Message 2 will select all unselected zones to message 3
15	As above	Message 3 will select all unselected zones to message 4

To set the mode. Move the cursor along until it flashes beneath the MODE window. Values between 0-9 may be entered directly using the numbered keys. Note the cursor automatically steps to the next window. Or using the + or – keys will increase or decrease the value between 00 and 15.

- Press the Page down key again. The display steps to the page microphone mode.

```

-----
| P1&2   out | 01-04 | 05-08 | 09-12 | 13-16 | 17-20 |
| page mode| 00 | 00 | 00 | 00 | 00 | 00 | 00 | 00 | 00 |
-----

```

Normal paging from BVRM microphone may be barred to any of the zone outputs 01-20 by entering a code in the section below the required zone output. The first section is assigned to Port 1 and the second to Port2.

```

-----
| P1&2   out | 01-04 | 05-08 | 09-12 | 13-16 | 17-20 |
| page mode| 00 | 00 | 00 | 00 | 00 | 00 | 00 | 00 | 00 |
-----
Port1 ↑   ↑ Port2

```

To enter a code move the cursor along until it flashes beneath the window of output required. Values between 0-9 may be entered directly using the numbered keys or using the + or – keys will increase or decrease the value between 00 and 15.

## CODES FOR ZONE OUTPUT BARRING

Code	Zone Output			
	01	02	03	04
0	0	0	0	0
1	1	0	0	0
2	0	1	0	0
3	1	1	0	0
4	0	0	1	0
5	1	0	1	0
6	0	1	1	0
7	1	1	1	0
8	0	0	0	1
9	1	0	0	1
10	0	1	0	1
11	1	1	0	1
12	0	0	1	1
13	1	0	1	1
14	0	1	1	1
15	1	1	1	1

1 = Barred Zone output

For Zone Outputs 05-08 use above table substituting 01-04 for 05-08.  
Repeat substitution for other zone outputs.

Example

```

-----
| Pl&2   out | 01-04 | 05-08 | 09-12 | 13-16 | 17-20 |
| page mode | 06 | 00 | 00 | 00 | 14 | 00 | 00 | 00 | 00 |
-----
                ↑           ↑
            02 & 03     10, 11 & 12
  
```

In above example zone outputs 02, 03, 10, 11 & 12 would be barred on Port1.

- Press the Page down key again.  
The display steps to the 1<sup>st</sup> page of BVRM zone positions, 01-10.

```

-----
| PORT 1 out | 01 | 02 | 03 | 04 | 05 | 06 | 07 | 08 | 09 | 10 |
| a=00 b=00 | 01 | 02 | 03 | 04 | 05 | 06 | 07 | 08 | 09 | 10 |
-----
  
```

Any of the 10 outputs 1-10 can be selected individually or collectively to appear as any single zone on the BVRM microphone.  
To change a zone selection, move the cursor along until it flashes beneath the required output window. Press 0 if this output is not required to appear on the BVRM.  
If the zone required is between 1-9, enter it directly using the numbered keys, or using the + or – keys step to the zone required between 00 and 63.

- Press the Page down key again.  
The display steps to the 2<sup>nd</sup> page of BVRM zone positions, 01-10.

```

-----
| PORT 1 out|01|02|03|04|05|06|07|08|09|10 |
| group mode|01|02|03|04|05|06|07|08|09|10 |
-----

```

- Press the Page down key again.  
The display steps to the 3<sup>rd</sup> page of BVRM zone positions, 11-20.

```

-----
| PORT 1 out|11|12|13|14|15|16|17|18|19|20 |
| c=00 d=00)|11|12|13|14|15|16|17|18|19|20 |
-----

```

Any of the 10 outputs 11-20 can be selected individually or collectively to appear as any single zone on the BVRM microphone. To change a zone selection, move the cursor along until it flashes beneath the required output window.

Press 0 if this output is not required to appear on the BVRM.

If the zone required is between 1-9, enter it directly using the numbered keys, or using the + or – keys step to the zone required between 00 and 63.

- Press the Page down key again.  
The display steps to the 4<sup>th</sup> page of BVRM zone positions.

```

-----
| PORT 1 out|11|12|13|14|15|16|17|18|19|20 |
| group mode|11|12|13|14|15|16|17|18|19|20 |
-----

```

In group mode any of the 20 outputs 1-20 can be selected in any combination to appear as any single zone by assigning “a”, “b” “c” and “d” (1<sup>st</sup> and 3<sup>rd</sup> page) to a Zone Switch on the BVRM.

- Press the Page up key until 1<sup>st</sup> page of BVRM zone positions is displayed.

```

-----
| PORT 1 out|01|02|03|04|05|06|07|08|09|10 |
| a=00 b=00)|01|02|03|04|05|06|07|08|09|10 |
-----

```

Move the cursor along until it flashes beneath “a” or “b”. If the BVRM switch required is between 1-9, enter it directly using the numbered keys, or using the + or – keys step to the BVRM switch number required between 00 and 63.

If “c” and “d” are required then page down to the 3<sup>rd</sup> page of BVRM zone positions and repeat as above.

- Press the Page up or down key until the display steps to the 2<sup>nd</sup> page of BVRM zone positions.

```

-----
| PORT 1 out|01|02|03|04|05|06|07|08|09|10 |
| group mode|01|02|03|04|05|06|07|08|09|10 |
-----

```

If an output between 1-10 is required for the assigned switch “a” then move the cursor along until it flashes beneath that window and then enter 01.

If an output between 1-10 is required for the assigned switch “b” then move the cursor along until it flashes beneath that window and then enter 02. If it has already been assigned to “a” then the value 03 (a+b) must be entered.

For outputs 11-20 page down to the 4<sup>th</sup> page of BVRM zone positions and repeat as above.

When using a combination of “a”, “b” “c” and “d” refer to code table below to enter correct code for output operation in 2<sup>nd</sup> and 4<sup>th</sup> page of BVRM zone positions.

00 = 0	08 = d
01 = a	09 = a+d
02 = b	10 = b+d
03 = a+b	11 = a+b+d
04 = c	12 = c+d
05 = a+c	13 = a+c+d
06 = b+c	14 = b+c+d
07 = a+b+c	15 = a+b+c+d

#### Example

```

-----
| PORT 1 out |01|02|03|04|05|06|07|08|09|10 |
| a=07 b=11) |01|02|03|04|05|06|07|08|09|10 |
-----

```

```

-----
| PORT 1 out |01|02|03|04|05|06|07|08|09|10 |
| group mode |01|02|04|08|00|00|03|00|12|08 |
-----

```

```

-----
| PORT 1 out |11|12|13|14|15|16|17|18|19|20 |
| c=09 d=10) |11|12|13|14|15|16|17|18|19|20 |
-----

```

```

-----
| PORT 1 out |11|12|13|14|15|16|17|18|19|20 |
| group mode |07|00|00|00|00|15|00|00|00|00 |
-----

```

In above example : “ a ” = Switch 7 --- Operates outputs 1, 7, 11 & 16  
 “ b ” = Switch 11 --- Operates outputs 2, 7, 11 & 16  
 “ c ” = Switch 9 --- Operates outputs 3, 9, 11 & 16  
 “ d ” = Switch 10 --- Operates outputs 4, 9, 10 & 16

For values in bold refer to code table above.

16. Press the Page down key until the display steps to the 5<sup>th</sup> page of BVRM zone positions Port 2 01-10.

```

-----
| PORT 2 out |01|02|03|04|05|06|07|08|09|10 |
| a=00 b=00)|01|02|03|04|05|06|07|08|09|10 |
-----

```

For Port 2 settings for BVRM refer to sections 9-14 above.

17. Press the Page down key until the display steps to the message length settings.

```

-----
| MESSAGE    |01|02|03|04|05|06|07|MES SYNC |
| time secs  |00|00|00|00|00|00|00|mode  00 |
-----

```

Note: The DIL switches mounted on the OPT402 for message 1 should be set for the message length plus 5seconds. For messages 2 to 7 switches 1-7 should be on and switch 8 should be off.

The message lengths are set as follows.

Move the cursor along until it flashes beneath the required message window.

If the length (seconds) required is between 0-9, enter it directly using the numbered keys. Note the cursor automatically steps to the next message. Or using the + or – keys will increase or decrease the value between 00 and 63 seconds.

When several BVR20 are used on 1 site it may be desirable to synchronize messages to prevent an unwanted echo.

Synchronization is achieved by selecting 1 of the following modes:

- 00 No TX or RX
- 01 TX only
- 02 RX, message 1 only.
- 03 TX & RX, message 1 only.
- 04 RX, all messages.
- 05 TX & RX, all messages.

Note: When sync is required between dual messages 2 & 3, 4 & 5, 6 & 7 the message time must be the same e.g. 2 must be the same as 3.

To change the mode, move the cursor along until it flashes beneath the message sync window. Use keys 0-5 to select mode.

18. Press the Page down key again.  
The display steps to the 1<sup>st</sup> page of fire panel interface mode settings, inputs 01-10.

```

-----
| F/P input  |01|02|03|04|05|06|07|08|09|10 |
| input mode |RS|00|00|00|00|00|00|00|00 |
-----

```

↑

**Note:** Fire panel input 1 is always the reset input normally open non latching mode and can not be changed. When reset is applied there will be a 3 Second delay.

Inputs 2-10 may be individually selected to 1 of 4 modes.

Mode 00 Normally open (de energized) sounder circuit latching input.

Mode 01 Normally open (de energized) sounder circuit non latching input.

Mode 02 Normally closed (energized) fail safe latching input.

Mode 03 Normally closed (energized) fail safe non latching input.

To change the mode, move the cursor along until it flashes beneath the required fire panel input.

Use keys 0-3 to select mode.

19. Press the Page down key again.

The display steps to the 2<sup>nd</sup> page of fire panel interface mode settings, inputs 11-20.

```
-----  
| F/P  input|11|12|13|14|15|16|17|18|19|20 |  
| input  mode|00|00|00|00|00|00|00|00|00|00 |  
-----
```

Inputs 11-20 may be individually selected to 1 of 4 modes.

Mode 00 Normally open (de energized) sounder circuit latching input.

Mode 01 Normally open (de energized) sounder circuit non latching input.

Mode 02 Normally closed (energized) fail safe latching input.

Mode 03 Normally closed (energized) fail safe non latching input.

To change the mode, move the cursor along until it flashes beneath the required fire panel input.

Use keys 0-3 to select mode.

20. Press the Page down key again.

The display steps to the 1<sup>st</sup> page of fire panel input 02 message selection, outputs 01-10.

```
-----  
| F/P 02 out|01|02|03|04|05|06|07|08|09|10 |  
| message|01|02|02|02|02|02|00|00|00|00 |  
-----
```

When the fire panel input receives an alarm condition, any of the outputs can be selected to broadcast any message.

In the example above, if input 2 receives an alarm condition, output 01 will receive message 1, outputs 02, 03, 04, 05 & 06 will receive message 2 and outputs 07, 08, 09 & 10 will be silent.

Any of the 7 available messages 01 – 07 can be selected but in addition when sounder circuits using continuous output for evacuate and pulsing (1 sec on 1 sec off) for alert, messages 2-7 can be selected for the alert and message 1 for the evacuate. Note the latching mode must be used, see section 17.

- Message 12 = evac message 1, alert message 2.
- Message 13 = evac message 1, alert message 3.
- Message 14 = evac message 1, alert message 4.
- Message 15 = evac message 1, alert message 5.
- Message 10 = evac message 1, alert message 6.
- Message 11 = evac message 1, alert message 7.
- Message 8 = evac message 2, alert message 4.
- Message 9 = evac message 2, alert message 6.

To change a message, move the cursor along until it flashes beneath the required output 1-10 window. If the message required is between 0-9, enter it directly using the numbered keys, or using the + or – keys step to the message number required between 00 and 15.

21. Press the Page down key again.  
The display steps to the 2<sup>nd</sup> page of fire panel input 02 message start delay time selection, outputs 1-10.

```

-----
| F/P 02 out|01|02|03|04|05|06|07|08|09|10 |
| time 30sec|00|00|06|06|12|12|18|18|24|24 |
-----

```

On receipt of an alarm condition from the fire detection system, the message broadcast may be delayed to any output from 0 to 31.5 minutes, providing phased evacuation, a requirement for high rise buildings.

In the example above, outputs 1 and 2 would be evacuated instantly, outputs 3 and 4 after 3 minutes, outputs 5 and 6 after 6 minutes and so on.

Important: If a delay is not required ensure time settings are set to 00.

To change a message start delay time, move the cursor along until it flashes beneath the required output 1-10 window.  
If the time required is between 0-9, enter it directly using the numbered keys, or using the + or – keys step to the time in increments of 30 seconds, value between 00 and 63.

22. Press the Page down key again.  
The display steps to the 3<sup>rd</sup> page of fire panel input 02 message selection, outputs 11-20.

```

-----
| F/P 02 out|11|12|13|14|15|16|17|18|19|20 |
| message|00|00|00|00|00|00|00|00|00|00 |
-----

```

To change a message, move the cursor along until it flashes beneath the required output 11-20 window. If the message required is between 0-9, enter it directly using the numbered keys, or using the + or – keys step to the message number required between 00 and 15.

23. Press the Page down key again.

The display steps to the 4<sup>th</sup> page of fire panel input 02 message start delay time selection, outputs 11-20.

```
-----  
| F/P 02 out|11|12|13|14|15|16|17|18|19|20 |  
| time 30sec|00|00|00|00|00|00|00|00|00|00 |  
-----
```

On receipt of an alarm condition from the fire detection system, the message broadcast may be delayed to any output from 0 to 31.5 minutes, providing phased evacuation, a requirement for high rise buildings.

In the example above, outputs 11 to 20 would be evacuated instantly.

Important: If a delay is not required ensure time settings are set to 00.

To change a message start delay time, move the cursor along until it flashes beneath the required output 1-10 window.

If the time required is between 0-9, enter it directly using the numbered keys, or using the + or – keys step to the time required in increments of 30 seconds, value between 00 and 63

24. Press the Page down key again.

The display steps to the 1<sup>st</sup> page of fire panel input 03 message selection, outputs 01-10.

```
-----  
| F/P 03 out|01|02|03|04|05|06|07|08|09|10 |  
| message|01|02|02|02|02|00|00|00|00 |  
-----
```

Repeat 19 onwards for all 20 fire panel inputs.

25. Press the Page down key again.

The display steps to the 1<sup>st</sup> page of message 01 monitored access selection for outputs 01-10.

```
-----  
| MES 01 out|01|02|03|04|05|06|07|08|09|10 |  
| a=00 b=00)|10|10|10|10|10|00|00|00|00 |  
-----
```

Any of the 54 access control inputs available on the 3 BVRCl termination modules may be programmed to route any of the 23 input sources to any of the 20 outputs when the control input is closed or via a 1k2 resistor to 0V.

In the example above, if input access 10 were closed to 0V via a 1k2 resistor message 01 would be broadcast to outputs 01-05 and outputs 06-10 would be silent. Therefore it is possible to program an access input to select any output or group of outputs. If MES 01 (audio input 5) has surveillance enabled, access input 10 will be monitored and faults will be announced if the access input is not correctly terminated.

**Note:**

Inputs 1-8 on the 1<sup>st</sup> BVRCl are used for page microphones 1-8 press to speak access.  
Inputs 1-8 (19-26) on the 2<sup>nd</sup> BVRCl are used for ambient noise sensors outputs 1-8 and  
inputs 1-8 (37-44) on the 3<sup>rd</sup> BVRCl are used for ambient noise sensors outputs 9-16.  
If not required any of the above inputs may be programmed to provide access to any of the audio channels.

To change the access input, move the cursor along until it flashes beneath the required output 1-10 window. If the access input required is between 0-9, enter it directly using the numbered keys, or using the + or – keys step to the number required between 00 and 54.

26. Press the Page down key again.  
The display steps to the 2<sup>nd</sup> page of message 01 monitored access selection for outputs 1-10.

```
-----
| MES 01 out|01|02|03|04|05|06|07|08|09|10 |
| group mode|00|00|00|00|00|00|00|00|00|00 |
-----
```

27. Press the Page down key again.  
The display steps to the 3<sup>rd</sup> page of message 01 monitored access selection for outputs 11-20.

```
-----
| MES 01 out|11|12|13|14|15|16|17|18|19|20 |
| c=00 d=00)|00|00|00|00|00|00|00|00|00|00 |
-----
```

To change the access input, move the cursor along until it flashes beneath the required output 1-10 window. If the access input required is between 0-9, enter it directly using the numbered keys, or using the + or – keys step to the number required between 00 and 54.

28. Press the Page down key again.  
The display steps to the 4<sup>th</sup> page of message 01 monitored access selection for outputs 11-20.

```
-----
| MES 01 out|11|12|13|14|15|16|17|18|19|20 |
| group mode|00|00|00|00|00|00|00|00|00|00 |
-----
```

For group mode settings refer to sections 13-15 above.

29. Press the Page down key until the display steps to the 1<sup>st</sup> page of message 02 monitored access selection for outputs 01-10.

```
-----
| MES 02 out|01|02|03|04|05|06|07|08|09|10 |
| a=00 b=00)|00|00|00|00|00|00|00|00|00|00 |
-----
```

Repeat 24 onwards for all 7 messages.

30. Press the Page down key again.  
The display steps to the 1<sup>st</sup> page of fire microphone 01 monitored access selection for outputs 01-10.

```
-----
| F/M 01 out|01|02|03|04|05|06|07|08|09|10 |
| a=00 b=00)|10|10|10|10|10|00|00|00|00|00 |
-----
```

Any of the 54 access control inputs available on the 3 BVRCI termination modules may be programmed to route any of the 23 input sources to any of the 20 outputs when the control input is closed or via a 1k2 resistor to 0V.

In the example above, if input access 10 were closed to 0V via a 1K2 resistor, fire microphone 01 would be broadcast to outputs 01-05 and outputs 06-10 would be silent. If F/M 01 (audio input 1) has surveillance enabled, access input 10 will be monitored and faults will be announced if the access input is not correctly terminated.

**Note:**

**Fire microphones 1-4 have a time out delay of 3 minutes and therefore will only allow the user to speak for this time. When the 3 minutes has expired the system will release the microphone and an access fault will be announced.**

**Note:**

**If this fire microphone is to be accessed via the RS485 serial data link, an unterminated, unused input must be assigned to output 01 to enable monitoring of the serial link. Inputs 1-8 on the 1<sup>st</sup> BVRCI are used for page microphones 1-8 press to speak access.**

Inputs 1-8 (19-26) on the 2<sup>nd</sup> BVRCI are used for ambient noise sensors outputs 1-8 and inputs 1-8 (37-44) on the 3<sup>rd</sup> BVRCI are used for ambient noise sensors outputs 9-16. If not required any of the above inputs may be programmed to provide access to any of the audio channels.

To change the access input, move the cursor along until it flashes beneath the required output 1-10 window. If the access input required is between 0-9, enter it directly using the numbered keys, or using the + or – keys step to the number required between 00 and 54.

31. Press the Page down key again.  
The display steps to the 2<sup>nd</sup> page of fire microphone 01 monitored access selection for outputs 1-10.

```

-----
| F/M 01 out|01|02|03|04|05|06|07|08|09|10 |
| group mode|00|00|00|00|00|00|00|00|00|00 |
-----

```

32. Press the Page down key again.  
The display steps to the 3<sup>rd</sup> page of fire microphone 01 monitored access selection for outputs 11-20.

```

-----
| F/M 01 out|11|12|13|14|15|16|17|18|19|20 |
| c=00 d=00)|00|00|00|00|00|00|00|00|00|00 |
-----

```

To change the access input, move the cursor along until it flashes beneath the required output 11-20 window. If the access input required is between 0-9, enter it directly using the numbered keys, or using the + or – keys step to the number required between 00 and 54.

33. Press the Page down key again.  
The display steps to the 4<sup>th</sup> page of fire microphone 01 monitored access selection for outputs 11-20.

```

-----
| F/M 01 out|11|12|13|14|15|16|17|18|19|20 |
| group mode|00|00|00|00|00|00|00|00|00|00 |
-----

```

For group mode settings refer to sections 13-15 above.

34. Press the Page down key until the display steps to the 1<sup>st</sup> page of fire microphone 02 monitored access selection for outputs 01-10.

```

-----
| F/M 02 out|01|02|03|04|05|06|07|08|09|10 |
| a=00 b=00)|00|00|00|00|00|00|00|00|00|00 |
-----

```

Repeat 29 onwards for all 4 fire microphones.

35. Press the Page down key until the display steps to the 1<sup>st</sup> page of page microphone 01 monitored access selection for outputs 01-10.

```

-----
| P/M 01 out|01|02|03|04|05|06|07|08|09|10 |
| a=00 b=00)|10|10|10|10|10|00|00|00|00|00 |
-----

```

Any of the 54 access control inputs available on the 3 BVRCI termination modules may be programmed to route any of the 23 input sources to any of the 20 outputs when the control input is closed or via a 1k2 resistor to 0V.

In the example above, if input access 10 were closed to 0V page microphone 01 would be broadcast to outputs 01-05 and outputs 06-10 would be silent. If P/M 01 (audio input 9) has surveillance enabled, access input 10 will be monitored and faults will be announced if the access input is not correctly terminated.

**Note:**

**Inputs 1-8 on the 1<sup>st</sup> BVRCI are used for page microphones 1-8 press to speak access. Inputs 1-8 (19-26) on the 2<sup>nd</sup> BVRCI are used for ambient noise sensors outputs 1-8 and inputs 1-8 (37-44) on the 3<sup>rd</sup> BVRCI are used for ambient noise sensors outputs 9-16. If not required any of the above inputs may be programmed to provide access to any of the audio channels. If a serial data link is used to access a page microphone input, the press to speak access input must be allocated.**

To change the access input, move the cursor along until it flashes beneath the required output 1-10 window.

If the access input required is between 0-9, enter it directly using the numbered keys, or using the + or – keys step to the number required between 00 and 54.

36. Press the Page down key again.  
The display steps to the 2<sup>nd</sup> page of page microphone 01 monitored access selection for outputs 1-10.

```
-----
| P/M 01 out|01|02|03|04|05|06|07|08|09|10 |
| group mode|00|00|00|00|00|00|00|00|00|00 |
-----
```

37. Press the Page down key again.  
The display steps to the 3<sup>rd</sup> page of page microphone 01 monitored access selection for outputs 11-20.

```
-----
| P/M 01 out|11|12|13|14|15|16|17|18|19|20 |
| c=00 d=00)|00|00|00|00|00|00|00|00|00|00 |
-----
```

To change the access input, move the cursor along until it flashes beneath the required output 11-20 window.

If the access input required is between 0-9, enter it directly using the numbered keys, or using the + or – keys step to the number required between 00 and 54.

38. Press the Page down key again.  
The display steps to the 4<sup>th</sup> page of page microphone 01 monitored access selection for outputs 11-20.

```
-----
| P/M 01 out|11|12|13|14|15|16|17|18|19|20 |
| group mode|00|00|00|00|00|00|00|00|00|00 |
-----
```

For group mode settings refer to sections 13-15 above.

39. Press the Page down key until the display steps to the 1<sup>st</sup> page of page microphone 02 monitored access selection for outputs 01-10.

```
-----
| P/M 02 out|01|02|03|04|05|06|07|08|09|10 |
| a=00 b=00)|00|00|00|00|00|00|00|00|00|00 |
-----
```

Repeat 34 onwards for all 8 page microphones.

40. Press the Page down key until the display steps to the 1<sup>st</sup> page of auxiliary input 01 unmonitored access selection for outputs 01-10.

```
-----
| AUX 01 out|01|02|03|04|05|06|07|08|09|10 |
| a=00 b=00)|10|10|10|10|10|00|00|00|00|00 |
-----
```

Any of the 54 access control inputs available on the 3 BVRCI termination modules may be programmed to route any of the 23 input sources to any of the 20 outputs when the control input is closed or via a 1k2 resistor to 0V.

In the example above, if input access 10 were closed to 0V auxiliary 01, (audio input 17) would be broadcast to outputs 01-05 and outputs 06-10 would be silent.

**Note:**

Inputs 1-8 on the 1<sup>st</sup> BVRCI are used for page microphones 1-8 press to speak access.  
Inputs 1-8 (19-26) on the 2<sup>nd</sup> BVRCI are used for ambient noise sensors outputs 1-8 and  
inputs 1-8 (37-44) on the 3<sup>rd</sup> BVRCI are used for ambient noise sensors outputs 9-16.

If not required any of the above inputs may be programmed to provide access to any of the audio channels. To change the access input, move the cursor along until it flashes beneath the required output 1-10 window. If the access input required is between 0-9, enter it directly using the numbered keys, or using the + or – keys step to the number required between 00 and 54.

41. Press the Page down key again.  
The display steps to the 2<sup>nd</sup> page of auxiliary input 01 unmonitored access selection for outputs 1-10.

```
-----  
| AUX 01 out|01|02|03|04|05|06|07|08|09|10 |  
| group mode|00|00|00|00|00|00|00|00|00|00 |  
-----
```

42. Press the Page down key again.  
The display steps to the 3<sup>rd</sup> page of auxiliary input 01 unmonitored access selection for outputs 11-20.

```
-----  
| AUX 01 out|11|12|13|14|15|16|17|18|19|20 |  
| c=00 d=00)|00|00|00|00|00|00|00|00|00|00 |  
-----
```

To change the access input, move the cursor along until it flashes beneath the required output 11-20 window.

If the access input required is between 0-9, enter it directly using the numbered keys, or using the + or – keys step to the number required between 00 and 54.

43. Press the Page down key again.  
The display steps to the 4<sup>th</sup> page of auxiliary input 01 unmonitored access selection for outputs 11-20.

```
-----  
| AUX 01 out|11|12|13|14|15|16|17|18|19|20 |  
| group mode|00|00|00|00|00|00|00|00|00|00 |  
-----
```

For group mode settings refer to sections 13-15 above.

44. Press the Page down key until the display steps to the 1<sup>st</sup> page of auxiliary input 02 unmonitored access selection for outputs 01-10.

```
-----  
| AUX 02 out|01|02|03|04|05|06|07|08|09|10 |  
| a=00 b=00)|00|00|00|00|00|00|00|00|00|00 |  
-----
```

Repeat 39 onwards for all 4 auxiliary inputs.

45. Press the Page down key until the display steps to the 1<sup>st</sup> page of auxiliary inputs 1-4 remote volume control access selection for outputs 01-10.

```

-----
| AUX1-4 out|01|02|03|04|05|06|07|08|09|10 |
| volume in|18|18|00|00|00|00|00|00|00|00 |
-----

```

The volume of AUX 1-4 (music) inputs can be adjusted to any output or group outputs from a remote volume control. In the example above a 5k Ohm linear variable resistor connected between access input 18 and 0V would adjust the volume of outputs 1 and 2, minimum resistance equals maximum volume which can not exceed the set preset level. If remote volume control is not required on an output set the value to 00.

To change the access input, move the cursor along until it flashes beneath the required output 1-10 window.

If the access input required is between 0-9, enter it directly using the numbered keys, or using the + or – keys step to the number required between 00 and 54.

46. Press the Page down key again.  
The display steps to the 2<sup>nd</sup> page of auxiliary inputs 1-4 remote volume control access selection for outputs 11-20.

```

-----
| AUX1-4 out|11|12|13|14|15|16|17|18|19|20 |
| volume in|00|00|00|00|00|00|00|00|00|00 |
-----

```

To change the access input, move the cursor along until it flashes beneath the required output 11-20 window.

If the access input required is between 0-9, enter it directly using the numbered keys, or using the + or – keys step to the number required between 00 and 54.

47. Press the Page down key again.  
The display steps to the level access codes.

```

-----
| ACCESS CODE level| 01 | 02 | 03 | 04 |
| PASSWORD          |0000|0000|0000|0000 |
-----

```

The codes will only be displayed and changed if level 4 code has been entered following rotation of key, see step 2.

To change an access code, move the cursor along until it flashes beneath the required access code, enter the new code using the numbered keys.

Pressing Page up key enables you to step to the previous page.

**Note:**

**Once settings have been adjusted, always return the key to the anti clockwise position to prevent accidental adjustment.**

## BVRM DIL SWITCH SETTINGS.

1	2	3	4		Emergency Mode		Paging Mode	
0	0	0	0	FM1	Input 1	Priority 1	Input 1	Priority 12
1	0	0	0	FM2	Input 2	Priority 2	Input 2	Priority 13
0	1	0	0	FM3	Input 3	Priority 3	Input 3	Priority 14
1	1	0	0	FM4	Input 4	Priority 4	Input 4	Priority 15
0	0	1	0	PM1	Input 5	Priority 12	Input 9	Priority 16
1	0	1	0	PM2	Input 6	Priority 13	Input 10	Priority 17
0	1	1	0	PM3	Input 7	Priority 14	Input 11	Priority 18
1	1	1	0	PM4	Input 8	Priority 15	Input 12	Priority 19
0	0	0	1	PM5	Input 9	Priority 16	Input 13	Priority 20
1	0	0	1	PM6	Input 10	Priority 17	Input 14	Priority 21
0	1	0	1	PM7	Input 11	Priority 18	Input 15	Priority 22
1	1	0	1	PM8	Input 12	Priority 19	Input 16	Priority 23
0	0	1	1	AUX1	Input 13	Priority 20	Input 17	Priority 24
1	0	1	1	AUX2	Input 14	Priority 21	Input 18	Priority 25
0	1	1	1	AUX3	Input 15	Priority 22	Input 19	Priority 26
1	1	1	1	AUX4	Input 16	Priority 23	Input 20	Priority 27

5	6	7	8	BVR20 (Units)
0	0	0	0	1 only
1	0	0	0	1-2
0	1	0	0	1-3
1	1	0	0	1-4
0	0	1	0	1-5
1	0	1	0	1-6
0	1	1	0	1-7
1	1	1	0	1-8
0	0	0	1	1-9
1	0	0	1	1-10
0	1	0	1	1-11
1	1	0	1	1-12
0	0	1	1	1-13
1	0	1	1	1-14
0	1	1	1	1-15
1	1	1	1	1-16

When using RS485 port it is necessary to allocate a parallel input to the fire microphone or microphones to enable access faults. The parallel input must exist and unterminated. Several fire microphones may be allocated to the same input.

## BVR20 PAGE STRUCTURE (Pages 1-120)

- 1: Turn the key to show title page and software version.
- 2: Press page down. Asks for code. Factory default is 0000.
- 3: Enter code, press page down. Allows you to enter an output number (1-20) to jump into. **OR**
- 4: Press page down again. Allows you to jump into an input (1-20) or 'shortcut' into other configuration pages. Take 'IN' number and follow commands. PD = Page Down and PU = Page Up.

<b>BVR20 PAGE NUMBER</b>	<b>PAGE FUNCTION</b>	<b>BVR20 MANUAL PAGE</b>	<b>SHORTCUT 'IP....'</b>
1	Volume for I/P's 1-10 on O/P1.	Page 12	N/A
2	Volume for I/P's 11-20 on O/P1.	Page 13	N/A
3	Graphic equaliser on O/P1.	Page 13	N/A
4	Chime, Surveillance and AMB on O/P1.	Page 13-15	N/A
5 - 8	All of above on O/P2.	Page 12-15	N/A
9 - 12	All of above on O/P3.	Page 12-15	N/A
13 - 16	All of above on O/P4.	Page 12-15	N/A
17 - 20	All of above on O/P5.	Page 12-15	N/A
21 - 24	All of above on O/P6.	Page 12-15	N/A
25 - 28	All of above on O/P7.	Page 12-15	N/A
29 - 32	All of above on O/P8.	Page 12-15	N/A
33 - 36	All of above on O/P9.	Page 12-15	N/A
37 - 40	All of above on O/P10.	Page 12-15	N/A
41 - 44	All of above on O/P11.	Page 12-15	N/A
45 - 48	All of above on O/P12.	Page 12-15	N/A
49 - 52	All of above on O/P13.	Page 12-15	N/A
53 - 56	All of above on O/P14.	Page 12-15	N/A
57 - 60	All of above on O/P15.	Page 12-15	N/A
61 - 64	All of above on O/P16.	Page 12-15	N/A
65 - 68	All of above on O/P17.	Page 12-15	N/A
69 - 72	All of above on O/P18.	Page 12-15	N/A
73 - 76	All of above on O/P19.	Page 12-15	N/A
77 - 80	All of above on O/P20.	Page 12-15	N/A
81	Volume, Graphic and Mode on I/P1.	Page 16-17	N/A
82	Attenuation, Compression and Chime.	Page 17-19	N/A
83 - 84	All of above on I/P2.	Page 16-19	N/A
85 - 86	All of above on I/P3.	Page 16-19	N/A
87 - 88	All of above on I/P4.	Page 16-19	N/A
89 - 90	All of above on I/P5.	Page 16-19	N/A
91 - 92	All of above on I/P6.	Page 16-19	N/A
93 - 94	All of above on I/P7.	Page 16-19	N/A
95 - 96	All of above on I/P8.	Page 16-19	N/A
97 - 98	All of above on I/P9.	Page 16-19	N/A
99 - 100	All of above on I/P10.	Page 16-19	N/A
101 - 102	All of above on I/P11.	Page 16-19	N/A
103 - 104	All of above on I/P12.	Page 16-19	N/A
105 - 106	All of above on I/P13.	Page 16-19	N/A
107 - 108	All of above on I/P14.	Page 16-19	N/A
109 - 110	All of above on I/P15.	Page 16-19	N/A
111 - 112	All of above on I/P16.	Page 16-19	N/A
113 - 114	All of above on I/P17.	Page 16-19	N/A
115 - 116	All of above on I/P18.	Page 16-19	N/A
117 - 118	All of above on I/P19.	Page 16-19	N/A
119 - 120	All of above on I/P20.	Page 16-19	N/A

**BVR20 PAGE STRUCTURE (Pages 121-304)**

<b>BVR20 PAGE NUMBER</b>	<b>PAGE FUNCTION</b>	<b>BVR20 MANUAL PAGE</b>	<b>SHORTCUT 'IP....'</b>
121	Ports 1 & 2 TX, RX, Baud and Mode.	Page 20-22	IN 21
122	Bar normal paging from BVR mic's.	Page 22-23	IN 21 + PD + PD
123 - 126	Port 1 button allocations.	Page 23-25	IN 22 + PD + PU
127 - 130	Port 2 button allocations.	Page 23-26	IN 23 + PD + PU
131	Message timings and synchronisation.	Page 26	IN 24 + PD + PU
132 - 133	Fire alarm mode settings.	Page 26-27	IN 24 + PD
134 - 137	Fire panel I/P2 message selection.	Page 27-29	IN 25 + PD
138 - 141	Fire panel I/P3 message selection.	Page 27-29	IN 26 + PD
142 - 145	Fire panel I/P4 message selection.	Page 27-29	IN 27 + PD
146 - 149	Fire panel I/P5 message selection.	Page 27-29	IN 28 + PD
150 - 153	Fire panel I/P6 message selection.	Page 27-29	IN 29 + PD
154 - 157	Fire panel I/P7 message selection.	Page 27-29	IN 30 + PD
158 - 161	Fire panel I/P8 message selection.	Page 27-29	IN 31 + PD
162 - 165	Fire panel I/P9 message selection.	Page 27-29	IN 32 + PD
166 - 169	Fire panel I/P10 message selection.	Page 27-29	IN 33 + PD
170 - 173	Fire panel I/P11 message selection.	Page 27-29	IN 34 + PD
174 - 177	Fire panel I/P12 message selection.	Page 27-29	IN 35 + PD
178 - 181	Fire panel I/P13 message selection.	Page 27-29	IN 36 + PD
182 - 185	Fire panel I/P14 message selection.	Page 27-29	IN 37 + PD
186 - 189	Fire panel I/P15 message selection.	Page 27-29	IN 38 + PD
190 - 193	Fire panel I/P16 message selection.	Page 27-29	IN 39 + PD
194 - 197	Fire panel I/P17 message selection.	Page 27-29	IN 40 + PD
198 - 201	Fire panel I/P18 message selection.	Page 27-29	IN 41 + PD
202 - 205	Fire panel I/P19 message selection.	Page 27-29	IN 42 + PD
206 - 209	Fire panel I/P20 message selection.	Page 27-29	IN 43 + PD
210 - 213	Message 1 triggering from BVRCl card.	Page 29-30	IN 44 + PD
214 - 217	Message 2 triggering from BVRCl card.	Page 29-30	IN 45 + PD
218 - 221	Message 3 triggering from BVRCl card.	Page 29-30	IN 46 + PD
222 - 225	Message 4 triggering from BVRCl card.	Page 29-30	IN 47 + PD
226 - 229	Message 5 triggering from BVRCl card.	Page 29-30	IN 48 + PD
230 - 233	Message 6 triggering from BVRCl card.	Page 29-30	IN 49 + PD
234 - 237	Message 7 triggering from BVRCl card.	Page 29-30	IN 50 + PD
238 - 241	Fire mic 1 accessing from BVRCl card.	Page 30-32	IN 51 + PD
242 - 245	Fire mic 2 accessing from BVRCl card.	Page 30-32	IN 52 + PD
246 - 249	Fire mic 3 accessing from BVRCl card.	Page 30-32	IN 53 + PD
250 - 253	Fire mic 4 accessing from BVRCl card.	Page 30-32	IN 54 + PD
254 - 257	Page mic 1 accessing from BVRCl card.	Page 32-33	IN 55 + PD
258 - 261	Page mic 2 accessing from BVRCl card.	Page 32-33	IN 56 + PD
262 - 265	Page mic 3 accessing from BVRCl card.	Page 32-33	IN 57 + PD
266 - 269	Page mic 4 accessing from BVRCl card.	Page 32-33	IN 58 + PD
270 - 273	Page mic 5 accessing from BVRCl card.	Page 32-33	IN 59 + PD
274 - 277	Page mic 6 accessing from BVRCl card.	Page 32-33	IN 60 + PD
278 - 281	Page mic 7 accessing from BVRCl card.	Page 32-33	IN 61 + PD
282 - 285	Page mic 8 accessing from BVRCl card.	Page 32-33	IN 62 + PD
286 - 289	Aux 1 accessing from BVRCl card.	Page 33-34	IN 63 + PD
290 - 293	Aux 2 accessing from BVRCl card.	Page 33-34	IN 64 + PD
294 - 297	Aux 3 accessing from BVRCl card.	Page 33-34	IN 65 + PD
298 - 301	Aux 4 accessing from BVRCl card.	Page 33-34	IN 66 + PD
302 - 303	DC volume control I/P's.	Page 35	IN 67 + PD
304	Access level codes.	Page 35	IN 68 + PD

## **Software Versions & Release Notes**

### **BVR8-30. Released 25-10-2001**

Faster response time from ANS sensors.

### **BVR8-43. Released 21-07-2003**

Under high reverberation conditions it is possible that the level increase inhibit detector is not effective and the echo is sensed as ambient noise during pauses in the broadcast message. This run away is made more apparent if the sensor sensitivity is set too high and in a tunnel environment.

BVR8-43 allows the installer to select the freeze condition when the output has been selected i.e. the busy state.

As message 1, input 5 does not have the facility to select a chime, this is now used to select the ANS mode.

CHIME OFF Selects auto freeze when an output signal is detected at normal sensitivity.

CHIME 1-note Selects auto freeze when an output signal is detected at normal sensitivity or if the output has a busy condition.

CHIME 2-note Selects auto freeze when an output signal is detected at maximum sensitivity.

CHIME 3-note Selects auto freeze when an output signal is detected at maximum sensitivity or if the output has a busy condition.

### **BVR8-44 Released 26-08-2003**

Removed Audio Input on Fire Mic 1 to Fire Mic 4 delay when chime selected.

### **BVR8-44a Released 23-09-2003**

Corrected "Listen In" facility to enable use with more than one console when inputs 9-16 (PM1-8) are selected.

### **BVR8-44b Released 08-04-2004**

Corrected Group Select on Message CI Inputs.

### **BVR8-44c Released 20-04-2005**

Corrected "Listen In" when outputs are overlayed so second output from each BVR02 is monitored if first selected to same group.

Corrected outputs 17-20 (PM7-8 Clear) when "Listen In" function unused

## **BVRAMB Ambient Noise Supplement.**

This addendum to the BVR20 Microdrive manual assumes that the user is familiar with the operation of the BVR20 Microdrive.

### **General Description**

The BVRAMB Ambient Noise Sensing Microphone monitors the ambient noise in a given area and is used in conjunction with a BVRCI (Interface Module) which connects to the BVR20 mainframe via a BVRI040 (Input / Output Module).

The BVRAMB uses a Dynamic Microphone capsule, the output of which is amplified and converted to produce a variable current output. This output is used by the BVRCI to produce a voltage that is proportional to the level of ambient noise.

The amplifier used to convert the signal has band pass filtering that ensures the system only responds to ambient noise that affects the intelligibility of announcements.

The onboard Surveillance Tone Generator permanently monitors the microphone capsule. This level is factory preset to produce 0.5V across the 4K7 resistor mounted on the relevant input of the BVRCI. This ensures that personnel will be alerted should the microphone capsule or on board amplifier fail.

As the microphone converts the ambient noise level to a variable current output, only three wires are required to connect each BVRAMB to the BVRCI interface.

These connections are +VE supply (nominal 24V), 0V, and output, and as there are no audio paths these wires do not need to be screened (see attached diagram).

The only maintenance requirements for these microphones are to ensure that the capsule is kept clear of obstructions and occasionally cleaned to remove dust build up.

These units are tested and factory preset to ensure correct output levels are produced.

If a failure occurs then the module should be replaced and the faulty item returned for repair, as in extreme situations a module that is not operating correctly could cause system instability.

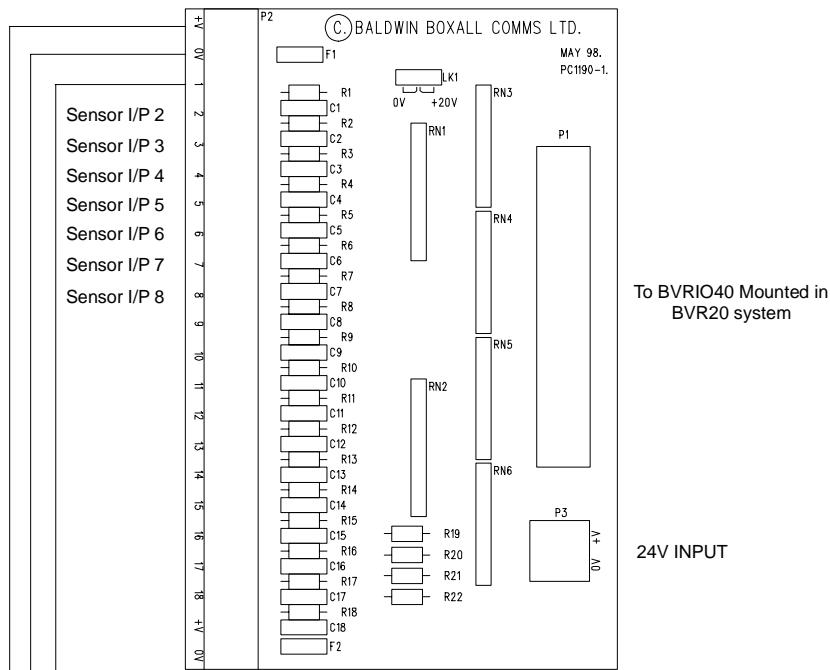
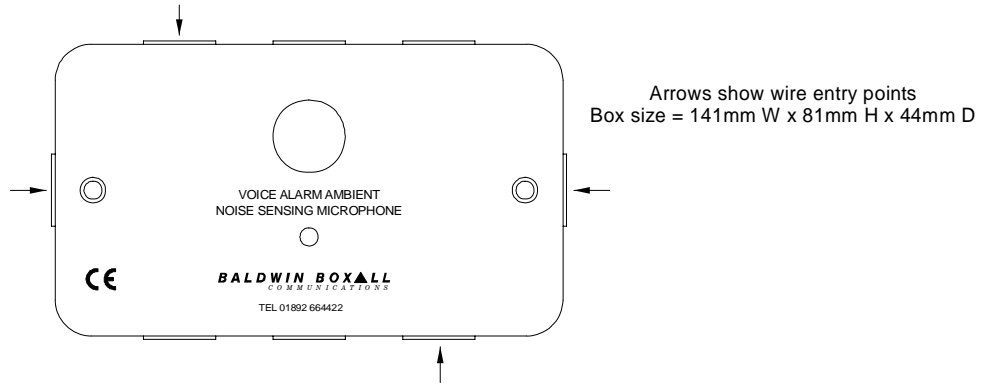

Connections from BVRC1 to BVRAMB  
See BVR20 setup details

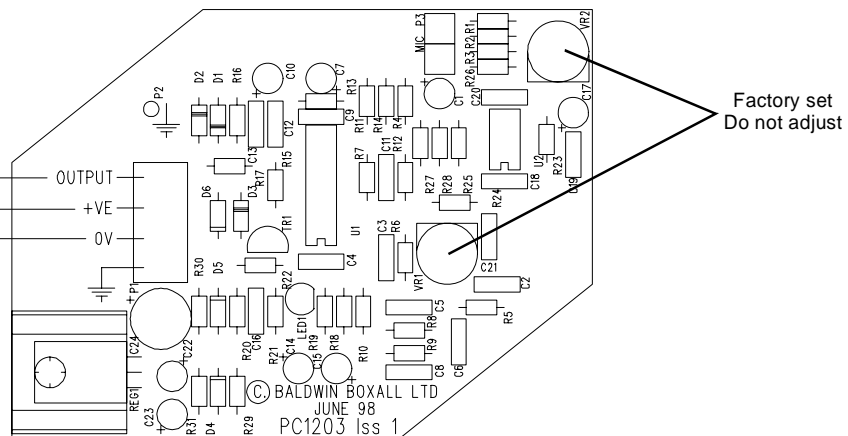

The Baldwin Boxall Ambient Noise System is based around the **BVR20** Microdrive. **BVRAMB** ambient noise sensors are connected to the BVR20 via **BVRCI** interface cards. The BVRCI cards connect via ribbon cable assemblies to **BVRIO40** cards located in the BVR20.

The BVR20 will accommodate sixteen ambient noise circuits with a maximum of two BVRAMB ambient noise sensors on each circuit.

Each BVRAMB circuit is terminated to a BVRCI card. Of the three available BVRCI cards only cards two and three have the ambient noise function. The terminations of these cards and their associated zones are shown in the following table.

BVRCI card 2 terminal number	BVR20 Output number
1	1
2	2
3	3
4	4
5	5
6	6
7	7
8	8

BVRCI card 3 terminal number	BVR20 Output number
1	9
2	10
3	11
4	12
5	13
6	14
7	15
8	16

**Note: Important.**

The BVRCI cards nominated for use with BVRAMB noise sensors must have their jumper link LK1 in the '0V' position.

## BVRAMB Ambient Noise Sensors

Care should be taken in the positioning of the **BVRAMB** ambient noise sensors, they need to be as close to the ambient noise source as possible, and as far away from the loudspeakers as possible. Do not position them in the dispersion angle of the loudspeakers, or close to a permanent noise source (air conditioning, fruit machines etc) In rooms with high ceilings position the sensor so that it is closer to the floor than the ceiling

Cables should be 3-core fire rated, with a conductor cross sectional area of 1.0mm or greater.

Two **BVRAMB** ambient noise sensors can be wired in parallel on the same circuit; a 4K7 compensation resistor is fitted at the **BVRCI** card. See following fig 1 for typical connection details.

**Fig 1**

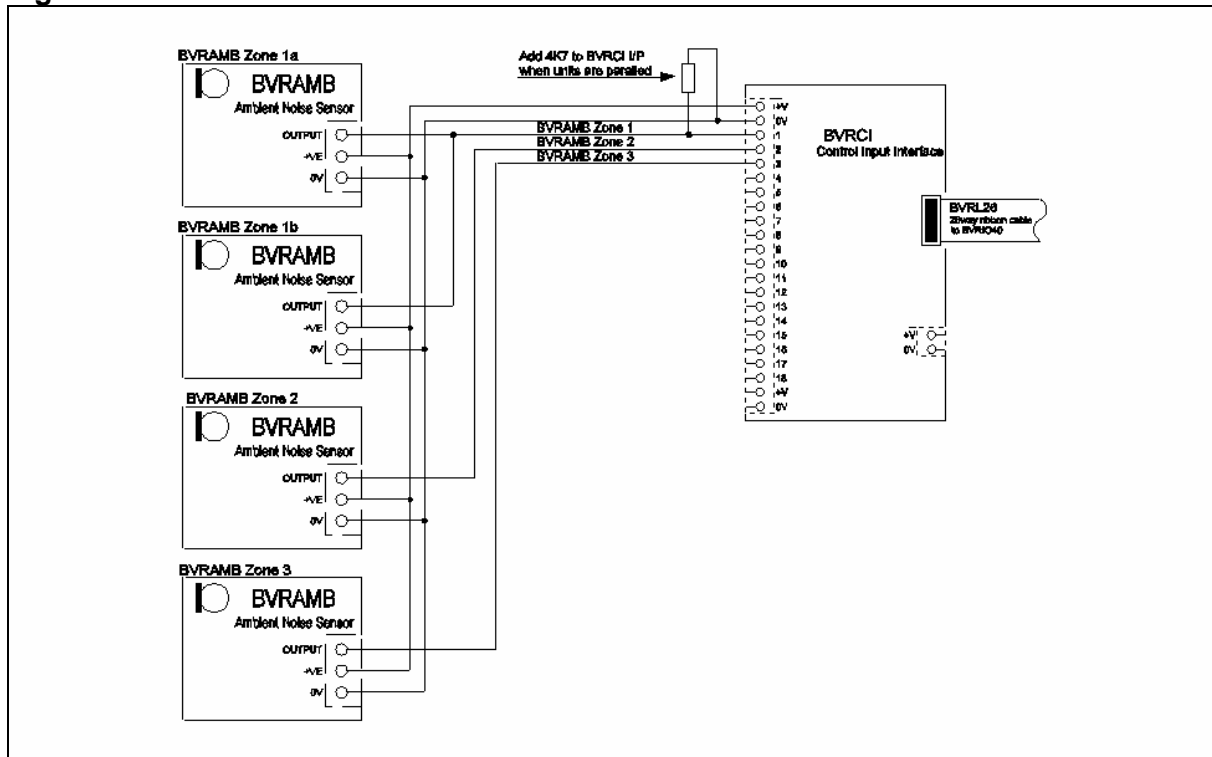

## Setting Up

The Ambient Noise Sensing function is controlled either from the BVR20 front panel, or a Laptop Computer if the Configuration software is fitted. The following identifies the BVR20 LCD screens, and assumes that the user has access authority.

With the **System Configuration Keyswitch** in the **ON** position, press the **PAGE DOWN** key, the first page will identify the software version of the BVR20. Press **PAGE DOWN** again and enter **User Code**, press **PAGE DOWN** until you come to the first of the output pages, (fig 2).

Fig 2

OUT 01	in	01	02	03	04	05	06	07	08	09	10
	volume	00	00	00	00	00	00	00	00	00	00

Before setting the ANS level it is important to establish two points

1. Set the maximum output volume required in the ANS zone, that is the volume demanded to meet a fully populated area, or with maximum ambient noise i.e. a train waiting at the platform.
2. That the figure entered for **volume** is within the limits **10 to 15**, this will allow the ANS to enable a full dynamic movement of the output volume. It may be necessary to reduce the associated input gain using the volume and attenuator controls on the **INPUT** page. The example below shows output volumes entered for Fire Microphone One, Message One, and Message Two, (fig 3).

Fig 3

OUT 01	in	01	02	03	04	05	06	07	08	09	10
	<b>volume</b>	<b>12</b>	00	00	00	<b>14</b>	<b>14</b>	00	00	00	00

Operate **PAGE DOWN** key twice this will bring you to the ambient noise page for output one, (fig 4).

Fig 4

OUT 01	CHIME	SURV	A=10	B=10	ANS	(-00	
	00	Out	10	2OK	A + B + Res	Sens	00

The right hand of the screen displays the two ambient noise sections. **ANS** displays the returned signal from the sensor; this is a dynamic figure and will vary between -00 and -12 with the ambient noise. The figure -00 represents no attenuation, whereas -12 represents the maximum (20dB) of attenuation.

**Sens** is the sensitivity of the noise sensor, the user enters this figure. The figure 00 will disable the ANS, i.e. OFF, maximum audio output. The figure 01 will enable the ANS and give the minimum sensitivity from the BVRAMB noise sensor; the maximum sensitivity that can be entered is 15, (fig 5).

**Fig 5**

OUT 01	CHIME	SURV	A=10	B=10	<b>ANS</b>	<b>(-00</b>
	00	Out 10	2OK	A + B + Res	<b>Sens</b>	<b>00</b>

Before making adjustment to the ANS it is important that the Surveillance Monitored is switched off, otherwise the ANS will detect this as a signal and freeze the output.

Simply reduce **SURV Out** to read **00** (fig 6).

**Fig 6**

OUT 01	CHIME	<b>SURV</b>	A=10	B=10	<b>ANS</b>	<b>(-00</b>
	00	<b>Out 00</b>	2OK	A + B + Res	<b>Sens</b>	<b>00</b>

Establish that the BVR20 is providing the maximum output as demanded by site conditions, and as described above.

In theory, if the ambient noise is at it's loudest, then the announcements should remain around 10dB above the ambient level. Once set, the loudspeaker volume will automatically adjust to the ambient noise level in that zone, from maximum output or to a minimum of 20dB of attenuation, (fig 7).

**Fig 7**

OUT 01	CHIME	SURV	A=10	B=10	<b>ANS</b>	<b>(-10</b>
	00	Out 10	2OK	A + B + Res	<b>Sens</b>	<b>05</b>

Note: Once settings have been adjusted, re-enter the original Surveillance Monitor (SURV) figure, always return the configuration key to the anti clockwise position.