

BVMS2 Mixer Output Module

Operating Instructions

Baldwin Boxall Communications Ltd.

Wealden Industrial Estate, Farningham Road
Crowborough, East Sussex, TN6 2JR

Telephone: 01892 664422 Fax: 01892 663146

Website: www.baldwinboxall.co.uk

Email: mail@baldwinboxall.co.uk

BALDWIN BOXALL
COMMUNICATIONS

BVMS 2

The BVMS2 has a DC controlled remote volume control facility. It is used with an MS2V remote volume control to provide adjustment of the overall gain of the amplifier. The BVMS2 is a BVMS1 output module with the additional board linked to it. It is possible to have the volume control operating on either Channel 1, Channel 2 or overall. This is determined by plugging into either J2, J3 or J4 on the BVMS1 board. They leave our factory plugged into J4 (overall).

Depending on the input module fitted and the selection of its internal switches the audio output signal may be routed to one of two bus lines. The output module type number BVMS1 has a virtual earth mixer stage connected to each of these audio signal paths. It is possible by switch selection to achieve priority on audio highway PA Pin No 5 Channel 1 over audio highway Channel 2 on Pin No 4. Channel 1 the priority channel incorporates a switchable low pass filter at 12KHz and the output may be routed direct to the output or via the bass and treble control. Channel 2 incorporates a high pass filter switchable at 300Hz and its output is routed via the tone controls to the output. Each channel has its own independent master gain control which are presented on the front panel.

The access terminal of the rear panel connector that the output stage occupies may be switched to either:

1. A pre-fade output from channel two for tape recording
2. DC controlled access channel one over channel two, connect to 0V to enable channel 1.
3. An unbalanced audio output when this module is fitted in the standard Adept amplifier main frame.
4. DC controlled remote volume when the remote volume control option is fitted.

Three four way connectors enable options to be inserted in the following positions:

- A. Channel 1 before the master gain control J2.
- B. Channel 2 before the master gain control J3.
- C. After the bass and treble control stage J4.

Another four way connector J1 is provided which enables the use of the virtual earth mixing stages as buffers to feed additional output stages, for example a system that requires a number of ambient noise sensors feeding independent areas. Switches associated with the input of the virtual earth amplifier provide the correct attenuation when used in this mode.

Each output module has 4 LEDs to indicate the output level, 5% 50% 100% and 120% the nominal output level i.e. 100% is 0.775V but signals to a maximum of 2.5V is possible.

SW2 SWITCH FUNCTIONS

1. **PRI** - set to 'ON' for priority.
Channel 1 when accessed will override Channel 2.
Note: to access Channel 1 select ACC switch 'ON' and connect access terminal to 0V.
Set 'OFF' to mix both channels together.
 2. **LP** - set 'on' to by pass the 12KHz low pass filter on Channel 1.
 3. * **OUT** - set to 'ON' to provide an unbalanced output from the access terminal or output to feed the power amplifier when fitted in an Adept mixer amplifier.
Note: set (4) ACC and (5) PF to 'OFF'.
 4. * **ACC** - set to 'ON' for priority access. Used in conjunction with PRI above.
Note:- set (3) OUT and (5) PF to 'OFF'.
 5. * **PF** - set to 'ON' to provide a prefade output from Channel 2 for tape recording etc.
Note: set (3) OUT and (4) ACC to 'OFF'.
 6. **TC** - set to 'ON' to route Channel 1 direct to the output, not via the bass and treble controls. Note: set (8) TC to 'OFF'.
 7. **HP** - set to 'ON' to bypass the 300Hz high pass filter on Channel 2.
 8. **TC** - set to 'ON' to route Channel 1 via the Bass and Treble controls.
Note: set (6) TC to 'OFF'.
- * ONLY SET ONE SWITCH TO THE 'ON' POSITION

SW1 SWITCH FUNCTIONS

1. Set to 'ON' for virtual earth (summing) input, normal mixing mode on Channel 2.
Set to 'OFF' for high impedance input, when used in the buffer mode.
2. Set to 'ON' for virtual earth (summing) input, normal mixing mode on Channel 1.
Set to 'OFF' for high impedance input, when used in the buffer mode.

BVMS2 SPECIFICATION

Floating Line Output	
Rated output level	: 0dBm (0.775V)
Maximum output level	: +9dBm (2.3V)
Output source impedance	: 130 Ohms
Distortion (1kHz rated output)	: Less than 0.1%
Frequency Response -3dB	: 30Hz - 20kHz
Output Noise (masters at min.)	: Better than 82dB
Signal to Noise Ratio (masters at max.)	: Better than 76dB
Tone Controls (internal - preset)	
Bass 100Hz	: +/- 15dB
Treble 10kHz	: +/- 15dB
High Pass Filter (selectable) Channel 2	: 300Hz @ 12dB per octave
Low Pass Filter (selectable) Channel 1	: 12kHz @ 12dB per octave
Front Panel Output Level Indicators	: 5%, 50%, 100%, 120%
Front Panel Controls	: Channel 1 & Channel 2 Masters
Internal Controls	: Preset Bass & Treble
Internal Selectors	: 8 way DIL switch to select filters, signal path and mode of operation.
	: 2 way DIL switch to select buffer mode when using more than one output module from the same input source.

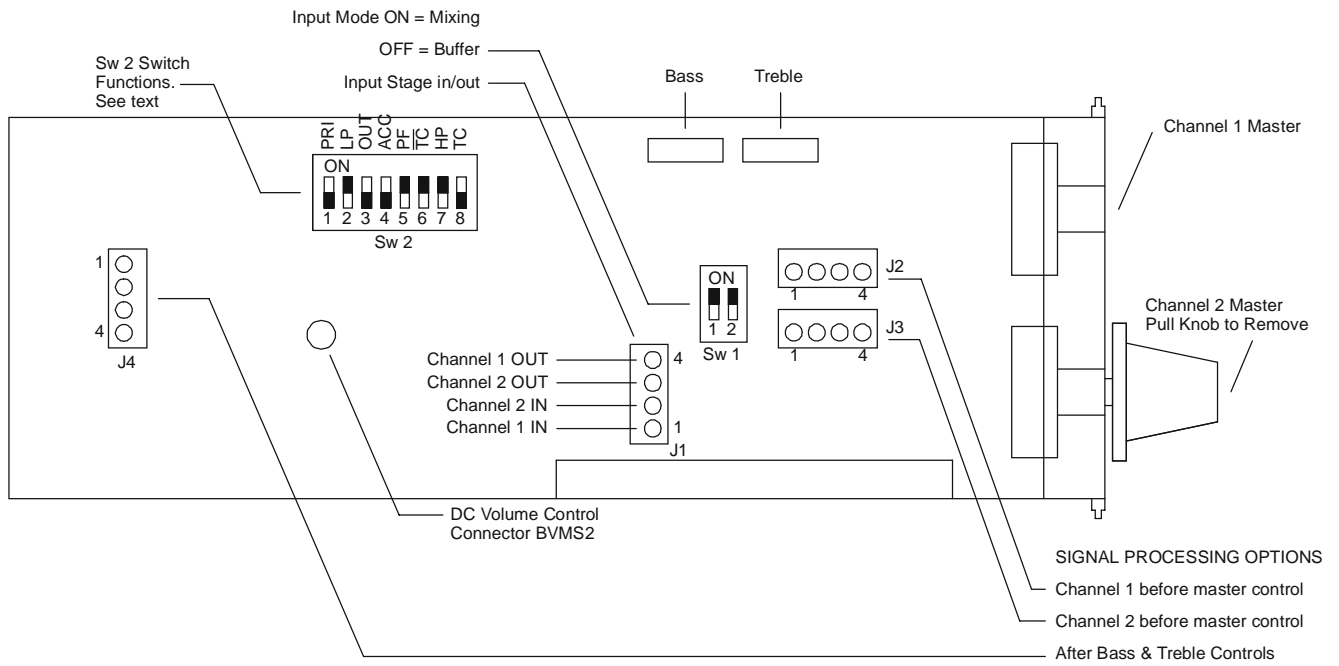

Fig 1: BVMS1 Connector and Switch Locations

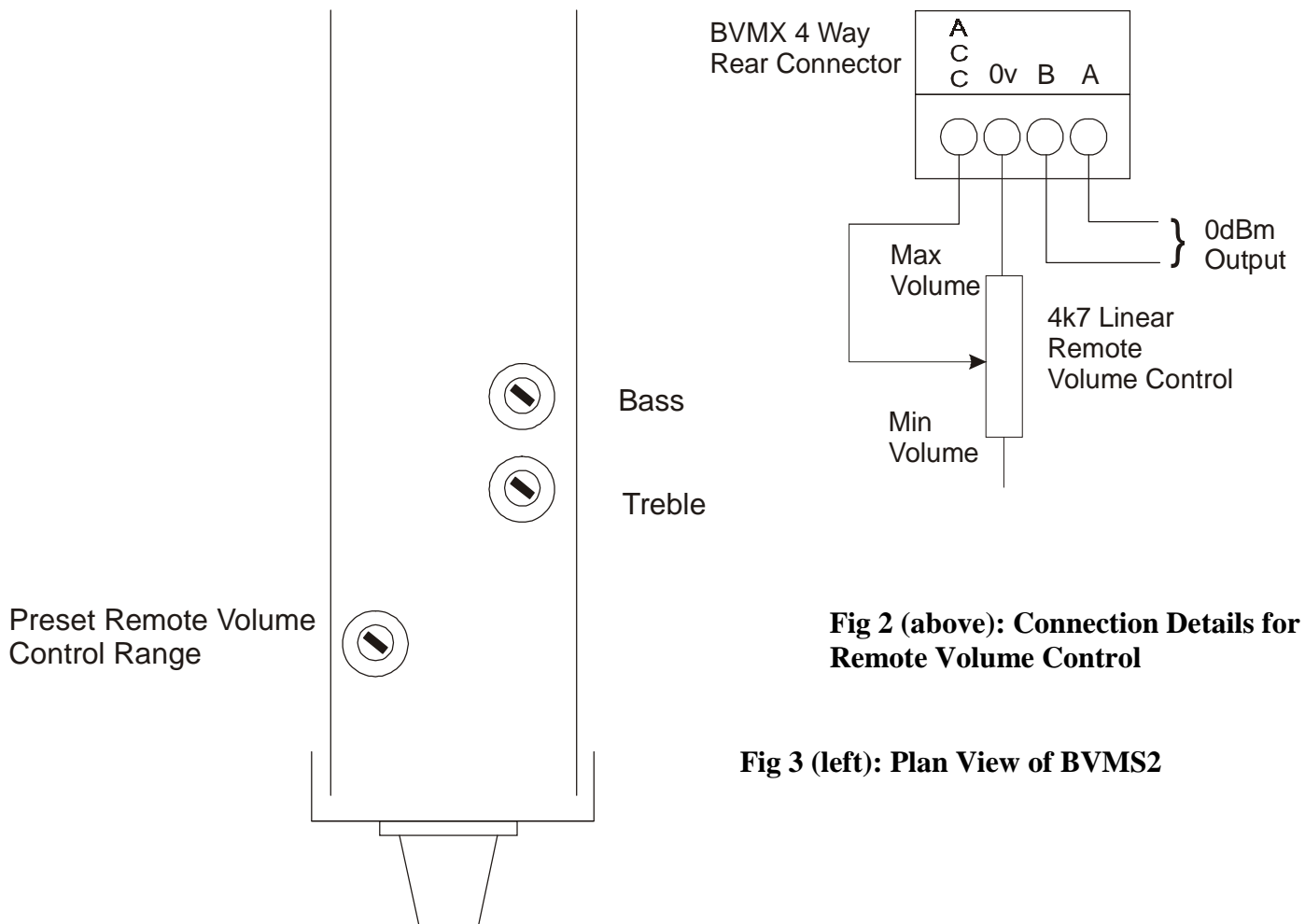

Fig 2 (above): Connection Details for Remote Volume Control

Fig 3 (left): Plan View of BVMS2