

Quickstart Installation Guide

BVFREPEM

The VIGIL Care repeater performs three functions: as a booster unit to enable cable runs exceeding 200 metres between Remote Units, as an interface for the BVOCDTA Toilet Alarm system and also as a remote Power Monitor.

For full installation instructions please refer to the OmniCare Installation Manual.

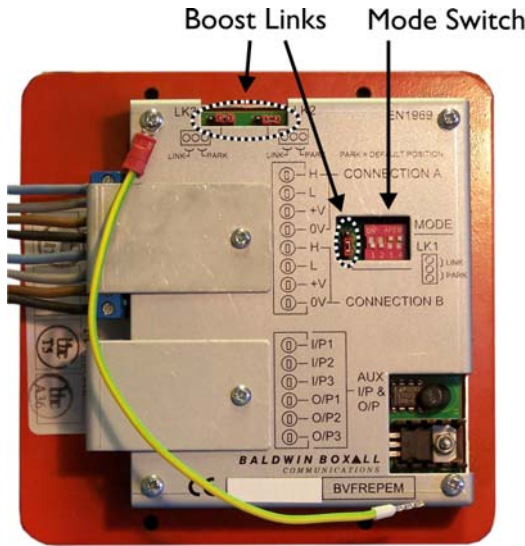

Option Jumpers & Switches

	Status	Option
LK1&2	Fitted	Reduces termination resistors to 75Ω *
LK3	Fitted	Increases output level of CANBus Drivers *
SW1	“ON”	Enables power monitoring
SW2	“ON”	Modifies monitoring voltage threshold

SW3	SW4	BVOCDTA Option
“OFF”	“OFF”	Toilet Alarm Not Active
“ON”	“OFF”	Toilet Alarm - FireCare
“OFF”	“ON”	Toilet Alarm - AssureCare
“ON”	“ON”	Toilet Alarm - OmniCare

* These jumpers should only be fitted when required since they increase the overall current consumption of the system.

Connection Details & Options when used as a BVOCDTA Interface

Ensure the DIL SW3 & SW4 are set to suit the installation as shown in the above table.

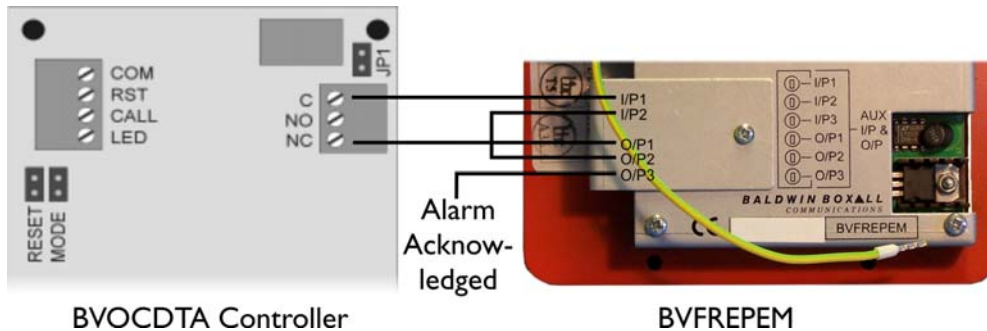

Note: The BVFREPEM includes a Normally Closed Fault Input between I/P 2 and O/P 2. These points must be linked to prevent a fault being announced.

If required an “Alarm Acknowledged” indicator can be connected to O/P3 (Open Collector output, 50mA max).

For OmniCare: All Toilet Alarms will appear together on the Control Panel at the end of the detected Remote Units. They will be in the order they are wired around the loop.

For FireCare: Toilet Alarms will appear on the Control Panel in the positions they are wired around the loop.

For AssureCare: Toilet Alarms will appear on the Control Panel in the positions they are wired around the loop and will only operate when the Fire Panel is Active.

Options when used as a Booster

The unit has three jumpers and as supplied these are fitted in a 'Park Position'.

LK1 if fitted increases the drive to the CAN bus allowing longer cable runs. However it also increases the amount of power used by the unit.

LK2 if fitted reduces the CAN bus termination resistor for connection 'A' this extends the length of cable that can be used however it also increases the amount of power used by the unit

LK3 if fitted reduces the CAN bus termination resistor for connection 'B' this extends the length of cable that can be used however it also increases the amount of power used by the unit.

Options when used with Power Monitoring

Care family Consoles fitted with FZON V2.11, FZON V3.02, FCZON V1.70 & FCZON V1.70+ or later will indicate an open circuit power fault in conjunction with BVFREPEMs.

A common fault will be indicated if a power line is open circuit or if the supply voltage exceeds normal limits. When a conversation takes place, the fault is cleared. The power is re-tested when the conversation ends. Power line open circuit monitoring is suspended during conversations.

Set SW 1 to "ON" to enable Power Monitoring. This monitors the supply and if 0v or +V becomes open circuit a message is sent to the console(s) which results in a common fault being indicated. If switch 2 is turned on while switch 1 is on then the 'low voltage threshold' is modified such that a fault is only indicated if the voltage at the device falls below about 12v (with switch 2 off the threshold is about 15v).

The voltage at any point on the circuit should not be below 15v so SW 2 would normally be off, however as the remote units can operate on voltages as low as 12v setting SW 2 ON will suppress false 'Low Voltage' fault indications in any installation that has voltages that low.

If monitoring for open circuit power is required at an installation a BVFREPEM should be fitted in each console to console circuit that has remote(s) on it. Ideally at the halfway (remotes) point.