

BVCRIPBG OmniCare **IP66 Back Box with** **Termination PCB**



Installation Instructions **BALDWIN BOX▲LL**

BVCRIPBG IP66 Back box Connection Details

This Back Box is fitted with a Termination PCB to allow site cabling to be terminated and tested prior to connecting the Remote Unit.

To ensure the Remote Unit is not damaged by incorrect site cable termination please ensure the following information is understood and the recommended tests are completed before connecting the Remote Unit.

All loop cabling should be 4 core with screen enhanced fire rated cable.

We recommend the colour coding of the loop cables should be as follows:

Blue: 0V

Brown: +V

Black: CAN L

Grey: CAN H

GND: Terminals on Back Box

We recommend both earth conductors are twisted together and connected to one of the ground terminals.

After terminating the site cabling ensure the Blue Block with Flying Lead is plugged into the "TEST" connector on the Termination board.

Testing Loop Cables

To prevent damage to Remote Units it is strongly recommended to check the site cabling PRIOR to applying power to the loop. The Termination Board provides a simple method to check cabling as the "Test" connector provides a loop-through function.

CAUTION: If there are Slave Control panels or other types of remote unit (without the termination board) on the loop ensure the Loop IN & OUT connections are linked together and the units are NOT CONNECTED to the loop cabling.

- 1) Ensure all DRS Back boxes on the loop have the flying lead connected to the "TEST" connector.
- 2) Ensure there is continuity between the two ends of each conductor on the loop.
- 3) Ensure there are no shorts to earth on any of the conductors.

BVCRIPBG IP66 Back Box Mounting & Assembly Instructions

This IP66 enclosure enables Refuge Remote units to be installed in exposed areas.

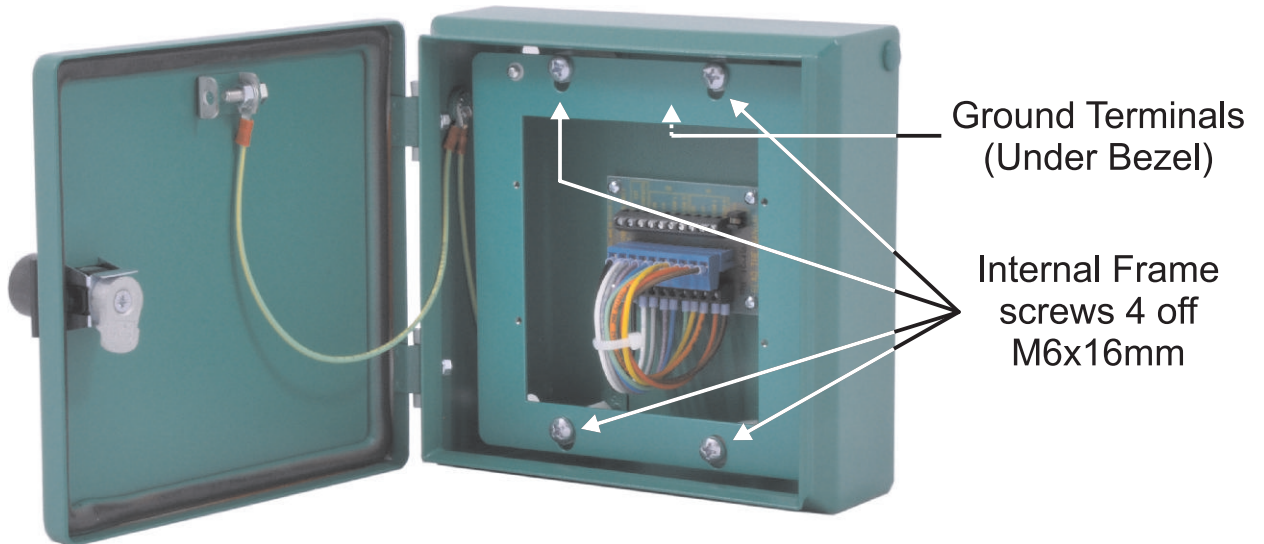

Installation notes

The enclosure does not have any glanding holes. Glanding holes will have to be drilled out to suit the cable requirements and suitable glands should be used to match the desired IP rating.

The enclosure is supplied pre-drilled with 4 off 8mm mounting holes. Remove the four Internal Frame securing screws to access the mounting holes. If these holes are not used rubber bungs are supplied and should be used to fill the holes.

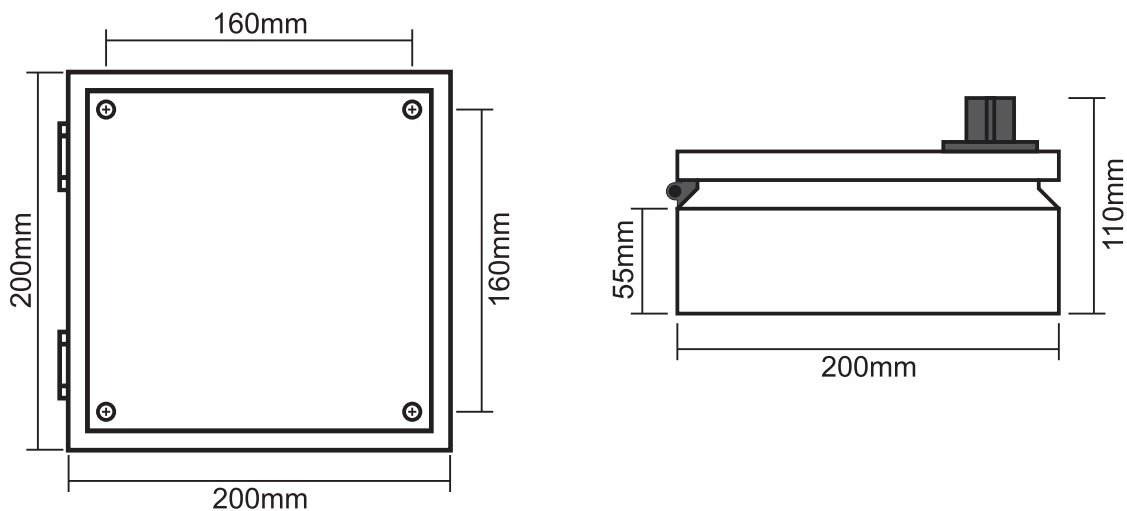

Fitting the Remote Unit

After performing site wiring checks (overleaf) connect the flying lead from the Termination PCB to the Remote Unit.

Connect the ground lead from the Remote Unit to the ground terminal on the enclosure.

Secure the Remote Unit to the Internal Frame using the M3.5x10 screws supplied.