

BATTERY CHARGERS

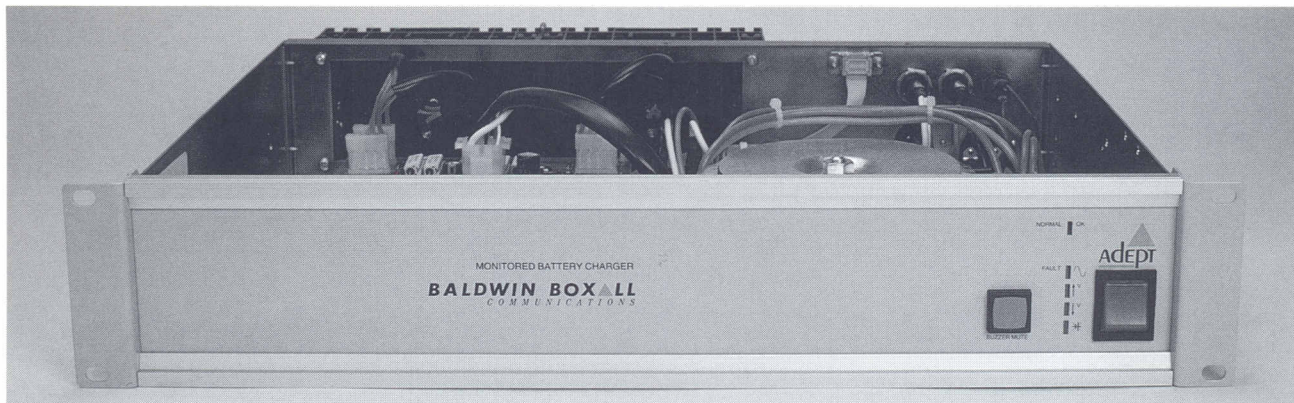

There are three battery chargers in the range. The BCR5 - 5 amp, BCR10 - 10 amp, BCR20 - 20 amp. These are for use with 24 V batteries.

Each charger is designed to charge and maintain, maintenance free sealed lead acid batteries. Using this type of battery means they are safe to be positioned close to amplifiers and associated equipment. We can recommend the sizes and types of batteries to be used with our systems.

The chargers are designed for continuous use and will charge and keep the batteries in a fully charged condition. The rated current of the charger will be supplied to a discharged battery. As the battery terminal voltage rises, regulators reduce the charging current until the voltage stabilises at 27.1V. Once this situation arises the charger will continue to float charge the batteries.

Each charger incorporates monitoring of various essential functions. L.E.D's on the front panel illuminate to indicate the fault conditions.

Indicators Are:-

NORMAL OK	Everything functioning correctly.
CHARGER FAULT OR MAINS FAILURE	
BATTERY VOLTAGE HIGH	
BATTERY VOLTAGE LOW	
BATTERY DISCONNECTED	

Should a fault condition occur in addition to led indication the internal buzzer will sound continuously. By depressing the 'Mute' button the buzzer will change to intermittent sounding. This is to remind the engineer that the fault condition still exists.

On rectification of the fault condition, the alarm will reset automatically and the 'Normal OK' green led will illuminate again.

Care must be taken when selecting the size of the charger to make sure it suits the battery capacity and recharge rates.

SPECIFICATION

AC Supply Input	220/240 V	50-60Hz
Maximum Power Consumption	5 AMP	150 VA
	10 AMP	300 VA
	20 AMP	700 VA

Note: The equipment must be earthed.

DC Output Voltage

Steady float voltage.	27.1 V
-----------------------	--------

DC Output Current

BCR5	5 AMP MAX
BCR10	10 AMP MAX
BCR20	20 AMP MAX

Connection Advice Correct polarity must be observed.

Fuse Protection

	MAINS	DC	OUTPUT	AUX DC ON PCB
Sizes	5 x 20mm	6.3 x 31.75mm	6.3 x 31.75mm	5 x 20mm
BCR5	T 3.15A	F10A	F10A	F 250mA
BCR10	T 3.15A	F20A	F20A	F 250mA
BCR20	T 6.3A	F25A	F25A	F 250mA

Size

482.6mm W x 88mm H x 350mm D

BALDWIN BOXALL

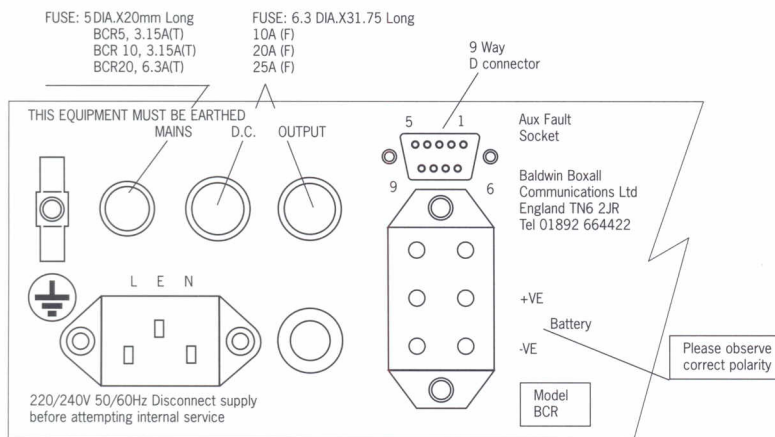

AUXILIARY FAULT SOCKET 9 WAY D-CONNECTOR

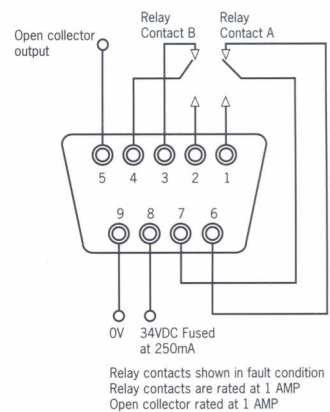

An auxiliary fault socket is provided on the rear panel. It is a 9 way 'D' connector. By connecting from the socket to external buzzers and relays, fault conditions can be indicated on remote fire alarm panels. This is a vital facility, particularly in fully monitored systems, when it is imperative that complete knowledge of satisfactory operation is available.

ADEPT BATTERY SIZING

OPERATING CURRENT

	STANDBY WITH INTERMITTENT LINE SURVEILLANCE (IMP 18 & BEL 1)	STANDBY WITHOUT LINE SURVEILLANCE	TOPE	SPEECH
1 - A60	0.4	0.3A	4.5A	2.5A
1 - A120	0.5	0.3A	9A	4A
1 - A260	0.6	0.3A	19A	7A

To calculate the battery sizes use the following formula.
 $(ST \times N \times SI) + (N \times OI \times OT) \times 1.25$

Where ST Standby time in hours.
 N Number of amplifiers.
 SI Standby current in amps.
 OI Operating current in amps.
 OT Operating time in hours.
 1.25 Allowance for 25% headroom.

Example 1 4 - A260 amplifiers, 24hr standby. 0.5 hour on speech load without line surveillance.

$$(24 \times 4 \times 0.3) + (4 \times 7 \times 0.5) \times 1.25 = 53.5 \text{ AH}$$

Therefore use the BY60 battery pack. The BCR5 charger will still recharge the batteries within 24 hours as required by BS5839.

Example 2 4 - A260 amplifiers, 24hr standby. 0.5 hour on speech load with loudspeaker line surveillance.

$$(24 \times 4 \times 0.6) + (4 \times 7 \times 0.5) \times 1.25 = 89.5 \text{ AH}$$

Therefore use the BY90 battery pack. The BCR5 charger will still recharge the batteries within 24 hours as required by BS5839.

BATTERY PACKS

CODE	DESCRIPTION	HEIGHT
BY6	Battery Pack 24 V 6AH	3U
BY15	Battery Pack 24 V 15AH	4U
BY60	Battery Pack 24 V 60AH	4U
BY90	Battery Pack 24 V 90AH	6U
BY180	Battery Pack 24 V 180AH	12U

ENGINEERS SPECIFICATION

The battery charger will be able to charge sealed lead acid batteries and maintain them at their correct voltage. The chargers must be designed to operate continually.

All essential functions and conditions should be constantly monitored. LED indicators situated on the front panel will show clearly the operating conditions. They will indicate all functions correct, charger fault, mains failure, battery voltage high, battery voltage low and battery disconnected.

In addition there should be a buzzer to draw attention to the fault. It must be possible to mute the buzzer. Once muted the buzzer will sound intermittently to remind the engineer that the fault condition still exists. The charger must reset automatically once the fault has been rectified.

An internal relay and open collector output will be provided on a 9 pin 'D' connector. This will enable connection to fire and other panels.

The mains, DC and output must be protected by fuses. These will be rated appropriate to the charging capacity of the unit. The charger will be rack mountable and will be 2 U high.

In our opinion the battery chargers manufactured by Baldwin Boxall Communications Limited. Tel: 01892 664422 comply.

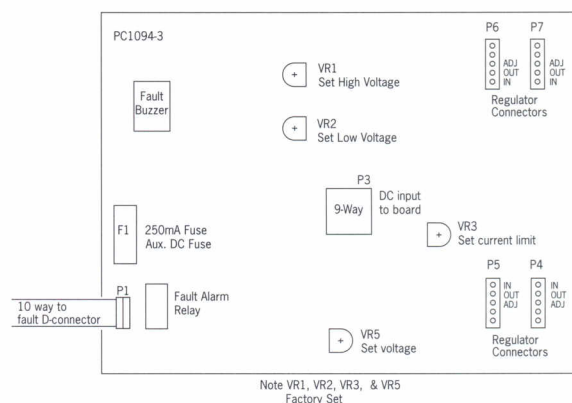

Baldwin Boxall Communications Ltd

Wealden Industrial Estate
 Farningham Road
 Crowborough
 East Sussex TN6 2JR
 Telephone: 01892 664422
 Fax: 01892 663146

**BALDWIN
 BOXALL**