

Adept AR10

Operating Instructions

AR10 ROUTING MIXER

The AR10 is a routing mixer and enables the routing of up to 10 inputs to any one of 10 outputs. It consists of a mounting frame and motherboard. Into the motherboard are plugged any of our input modules and the desired number of ARM output modules.

It is possible to group a number of inputs together using the priority circuits on the input modules. The output from the group can be routed through to the ARM output modules at the desired priority. This is achieved by using the 2 way DIL switches located on the AR10 motherboard.

Each input module except number 10 is connected to the input of a virtual earth mixer buffer amplifier. This is via DIL switches section 2 SW2, 4, 6, 8, 10, 12, 14, 16 and 18 see figure 5.

If input group priority is not required the above switches should be set 'ON' and all others 'OFF'. Section 1 of the above switches allows the output of the input modules to be mixed together in groups. They must only be fed to one virtual earth mixer by selecting 'OFF' the appropriate section 2 of the above switches.

The priority facility between input modules can be selected using SW1, 3, 5, 7, 9, 11, 13, 15 and 17.

Example: If inputs 1, 2 and 3 are required to have priority in a group and an output or input 1 buffer amplifier, the switches would be set as follows :-

<u>SW</u>	<u>SECTION 1</u>	<u>SECTION 2</u>	<u>SW</u>	<u>SECTION 1</u>	<u>SECTION 2</u>
1	ON	ON	10	OFF	ON
2	ON	ON	11	OFF	OFF
3	ON	ON	12	OFF	ON
4	ON	OFF	13	OFF	OFF
5	OFF	OFF	14	OFF	ON
6	OFF	OFF	15	OFF	OFF
7	OFF	OFF	16	OFF	ON
8	OFF	ON	17	OFF	OFF
9	OFF	OFF	18	OFF	ON

Selection of Input Priority

Input Priority is selected using straps between the required pins on the DIL header located on each of the Audio Routing Output Modules (ARM). Nine Input sources from the input modules are on the lower row whilst the 9 priority destination levels are presented on the upper row. Therefore, to select input 1 at the first priority, simply strap between input source 1 and priority level 1. Using this technique any input can be selected to any priority level. Priority level 9 is designated specifically for music signals providing a slow recovery to its maximum level.

Selection of Priority Type

Basically two types of priority can be set using the two DIL switches mounted on the ARM module, cascade and equal (1st come, 1st served). Using these switches a combination of both cascade and priority may be realised. For example if cascade is required on the first three and equal on the remaining five, select cascade switch 1, 2 and 3 'ON' and all others 'OFF'. Select equal switch 1, 2 and 3 'OFF' and all others 'ON'.

However if cascade priority is required on all eight select all cascade switches at the 'ON' position and select all equal switches 'OFF'.

Night Volume Reduction

The output can be reduced to a predetermined level by connecting pin 3 of the 25 way D connector to 0V, normally using a time switch. This facility is useful to reduce night time - local residence annoyance when speakers are mounted externally e.g. railway platforms. This reduced level is adjusted using the preset night volume reduction control mounted on the ARM module.

ARM MODULE

Floating Line Output

Rated Output Level	: 0dBm (0.775V)
Maximum Output Level	: +6Dbm (1.4v)
Output Source Impedance	: 130 Ohms
Distortion (1KHz rated output)	: Less than 0.1%
Frequency Response -3dB	: 30Hz - 20KHz
Output Noise (no input selected ref rated output)	: Better than 80dB
Night Volume Level Reduction adjustable from	: 0 - 26dB
Module Current Consumption with no inputs accessed	: 20mA
Module Current Consumption with 9 inputs accessed	: 62mA

AR10 MAIN FRAME

<u>Supply Voltage</u>	AC Supply 50 - 60Hz	: 220 - 240V
	DC Supply	: 23 - 30V
<u>Fuse Protection</u>	AC 5 x 20mm	: 2A (T)
	DC 6.3 x 31.75mm	: 3A (F)
	Battery 6.3 x 31.75mm	: 3A (F)
<u>Terminations</u>	AC Supply Input	: 3 Pin DIN-IEC6A
	DC Supply (Battery)	: 3 Pin Screw Terminated Connector
	Signal Input (10 off)	: 240 Deg 5 Pin DIN Locking
<u>Dimensions</u>	Depth (Front to Rear)	: 380mm (15")
	Width (Rack Mounted)	: 428.6mm (19")
	Height	: 88mm (3.5") 2 Unit
	Weight	: Approx 5 Kgs

The 25 way D connector is mounted at the rear of the ARM module.

PIN

FUNCTION

1	Line level 0dBm output balanced	
2	Line level 0dBm output balanced	
3	Night volume reduction	Connect to 0V to reduce output level
4	Priority 9 Select	Connect to 0V to select priority 9
5	Priority 2 Monitor output	
6	Priority 1 Acknowledge	Connects to 0V when priority 1 selected
7	Priority 2 Acknowledge	Connects to 0V when priority 2 selected
8	Priority 3 Acknowledge	Connects to 0V when priority 3 selected
9	Priority 4 Acknowledge	Connects to 0V when priority 4 selected
10	Priority 5 Acknowledge	Connects to 0V when priority 5 selected
11	Priority 6 Acknowledge	Connects to 0V when priority 6 selected
12	Priority 7 Acknowledge	Connects to 0V when priority 7 selected
13	Priority 8 Acknowledge	Connects to 0V when priority 8 selected
14	Busy Lamp/relay output	Connects to 0V when ARM module is busy
15	0 Volts	Common 0V for selection switches
16	+ 24 Volts	Common + 24V for lamps etc.
17	Priority 1 monitor output	
18	Priority 1 Select	Connect to 0V to select priority 1
19	Priority 2 Select	Connect to 0V to select priority 2
20	Priority 3 Select	Connect to 0V to select priority 3
21	Priority 4 Select	Connect to 0V to select priority 4
22	Priority 5 Select	Connect to 0V to select priority 5
23	Priority 6 Select	Connect to 0V to select priority 6
24	Priority 7 Select	Connect to 0V to select priority 7
25	Priority 8 Select	Connect to 0V to select priority 8

Figure 1 - A Typical System Configuration

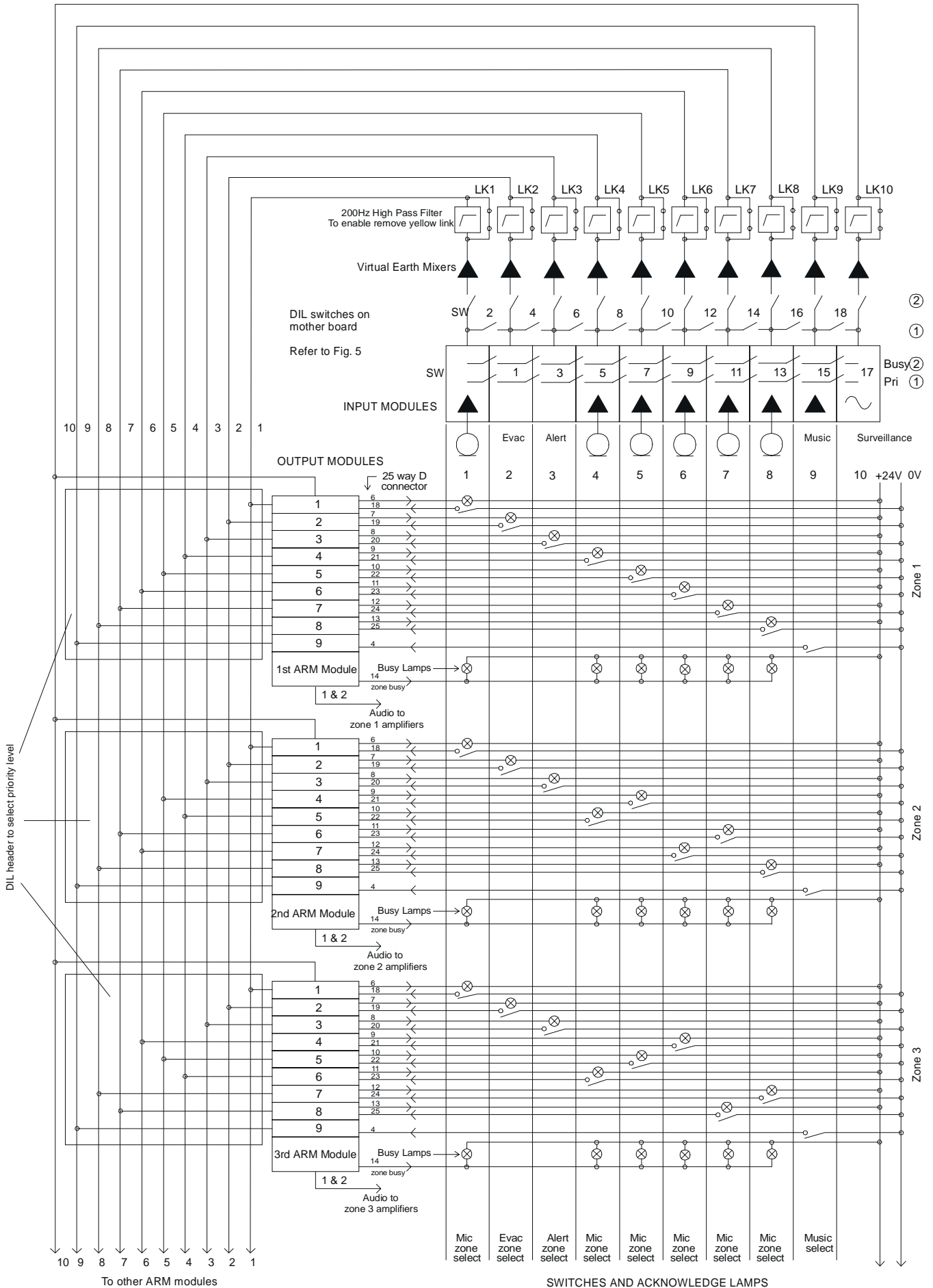

Figure 2 - ARM PCB Layout

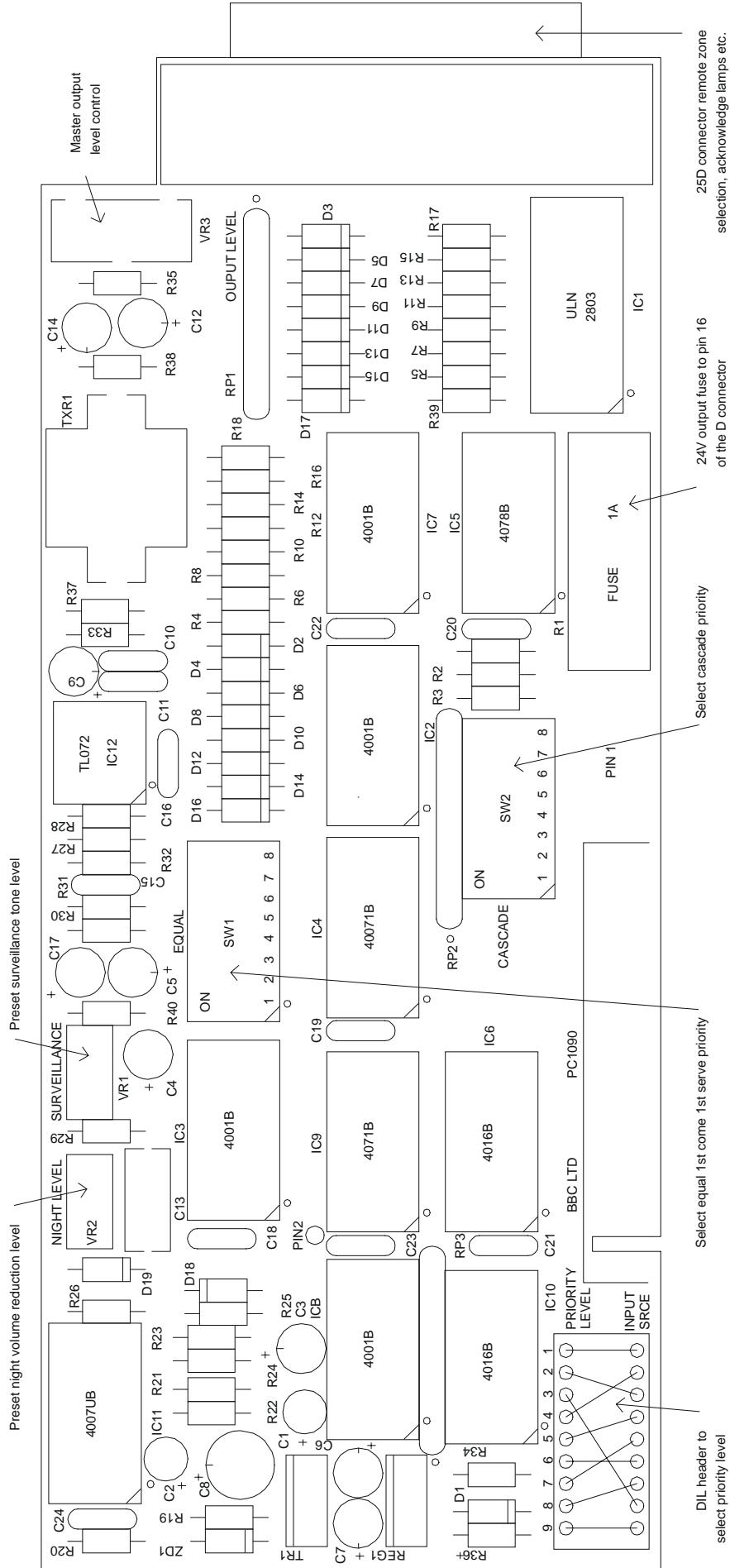

Figure 3 - Microphone and line Monitoring

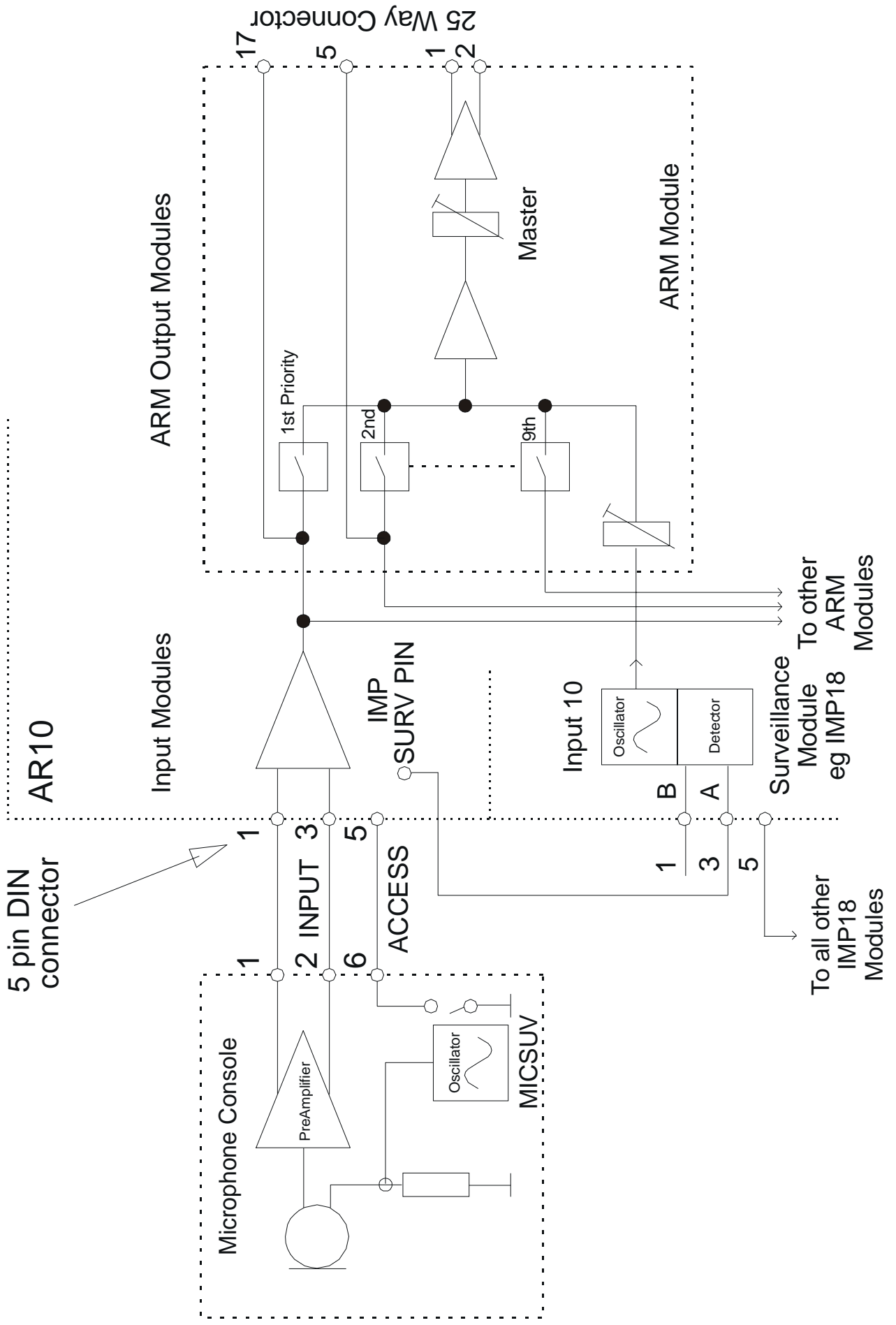

Figure 4 - AR10 Printed Circuit Board Layout

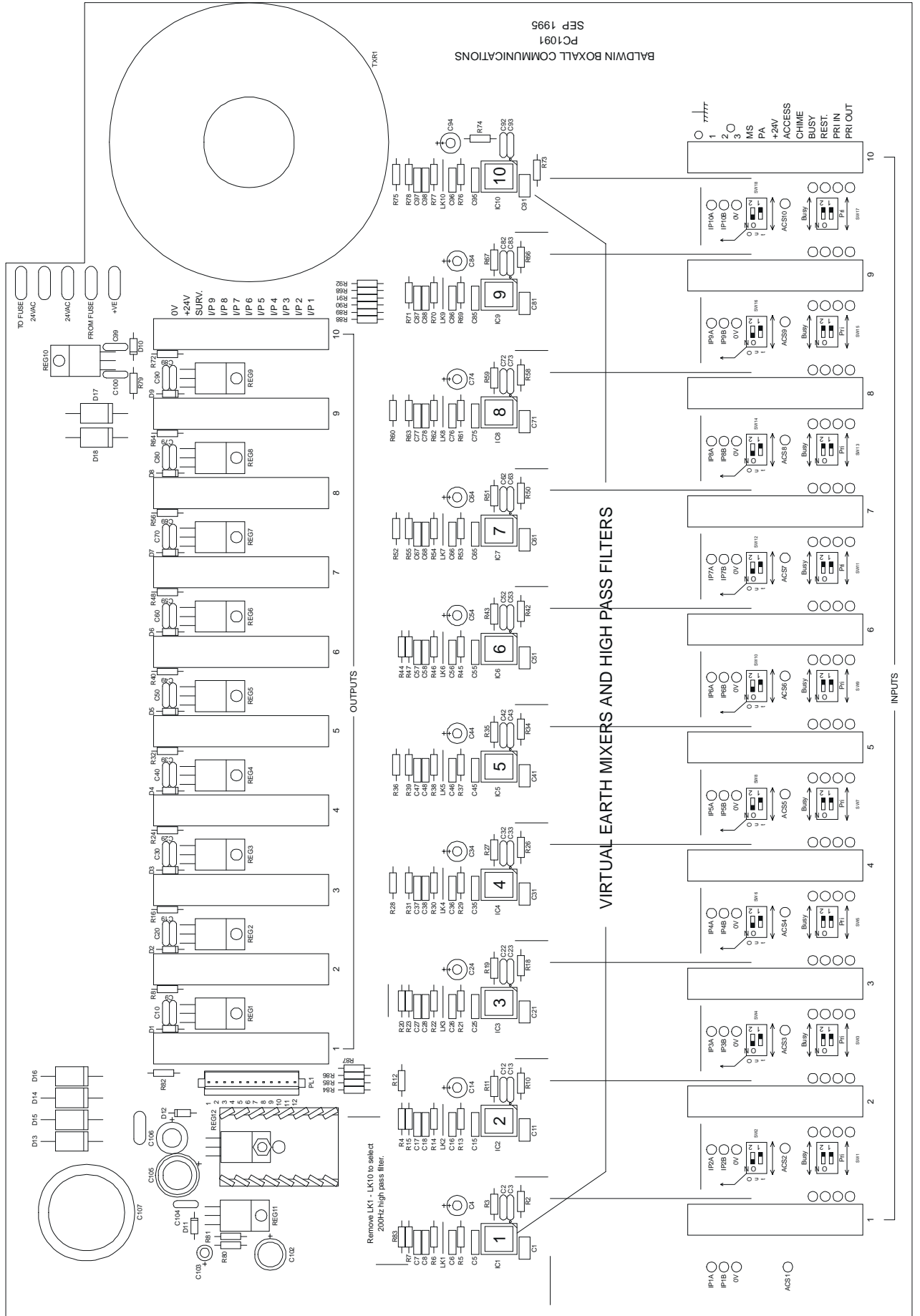

Figure 5 - AR10 Input Configuration

