

BVRAMB

Operating Instructions

Baldwin Boxall Communications Ltd.

Wealden Industrial Estate, Farningham Road
Crowborough, East Sussex, TN6 2JR

Telephone: 01892 664422 Fax: 01892 663146

Email: mail@baldwinboxall.co.uk

Website: www.baldwinboxall.co.uk

BALDWIN BOXALL
COMMUNICATIONS

BVRAMB AMBIENT NOISE SENSING MICROPHONE

TECHNICAL DESCRIPTION

The BVRAMB Ambient Noise Sensing Microphone monitors the ambient noise in a given area and is used in conjunction with a BVRCI (Interface Module) which connects to the BVR20 mainframe via a BVRIO40 (Input / Output Module).

The BVRAMB uses a Dynamic Microphone capsule, the output of which is amplified and converted to produce a variable current output. This output is used by the BVRCI to produce a voltage that is proportional to the level of ambient noise.

The amplifier used to convert the signal has band pass filtering that ensures the system only responds to ambient noise that affects the intelligibility of announcements.

The onboard Surveillance Tone Generator permanently monitors the microphone capsule. This level is factory preset to produce 0.5V across the 4K7 resistor mounted on the relevant input of the BVRCI. This ensures that personnel will be alerted should the microphone capsule or on board amplifier fail.

As the microphone converts the ambient noise level to a variable current output, only three wires are required to connect each BVRAMB to the BVRCI interface. These connections are +VE supply (nominal 24V), 0V, and output, and as there are no audio paths these wires do not need to be screened (see attached diagram).

The only maintenance requirements for these microphones are to ensure that the capsule is kept clear of obstructions and occasionally cleaned to remove dust build up.

These units are tested and factory preset to ensure correct output levels are produced.

If a failure occurs then the module should be replaced and the faulty item returned for repair, as in extreme situations a module that is not operating correctly could cause system instability.

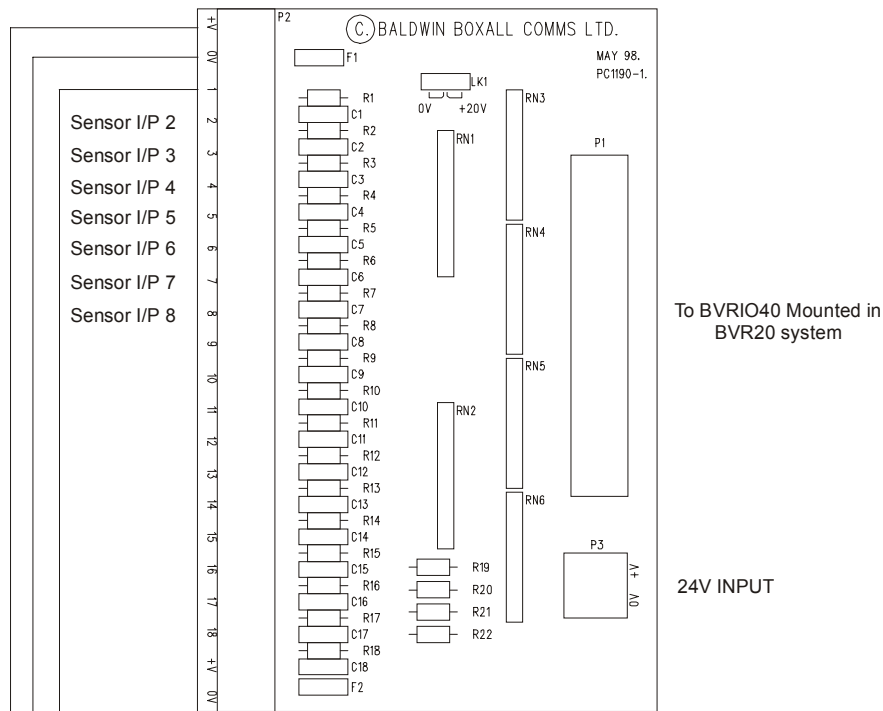
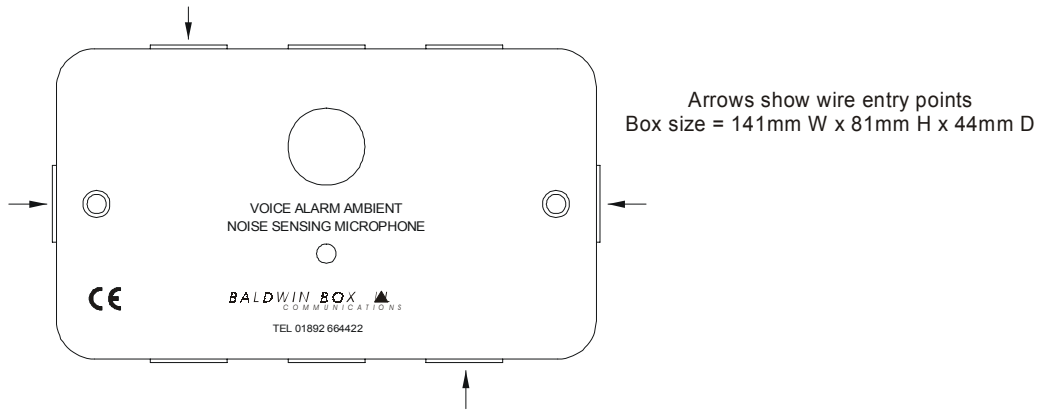

Connections from BVRCI to BVRAMB
See BVR20 setup details

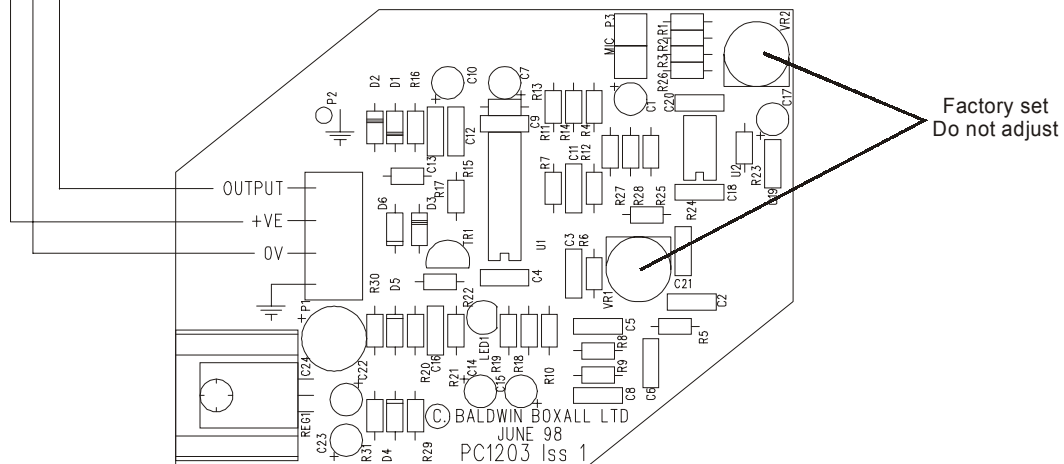

BVR20 Microdrive

Ambient Noise Supplement.

This addendum to the BVR20 Microdrive manual assumes that the user is familiar with the operation of the BVR20 Microdrive

General Description

The Baldwin Boxall Ambient Noise System is based around the **BVR20** Microdrive. **BVRAMB** ambient noise sensors are connected to the BVR20 via **BVRCI** interface cards. The BVRCI cards connect via ribbon cable assemblies to **BVRIO40** cards located in the BVR20.

The BVR20 will accommodate sixteen ambient noise circuits with a maximum of two BVRAMB ambient noise sensors on each circuit.

Each BVRAMB circuit is terminated to a BVRCI card. Of the three available BVRCI cards only cards two and three have the ambient noise function. The terminations of these cards and their associated zones are shown in the following table.

BVRCI card 2 terminal number	BVR20 Output number
1	1
2	2
3	3
4	4
5	5
6	6
7	7
8	8

BVRCI card 3 terminal number	BVR20 Output number
1	9
2	10
3	11
4	12
5	13
6	14
7	15
8	16

Note: Important.

The BVRCI cards nominated for use with BVRAMB noise sensors must have their jumper link LK1 in the '0V' position.

BVRAMB Ambient Noise Sensors

Care should be taken in the positioning of the **BVRAMB** ambient noise sensors, they need to be as close to the ambient noise source as possible, and as far away from the loudspeakers as possible. Do not position them in the dispersion angle of the loudspeakers, or close to a permanent noise source (air conditioning, fruit machines etc) In high ceiling rooms position the sensor so that it is closer to the floor than the ceiling

Cables should be 3-core fire rated, with a conductor cross sectional area of 1.0mm or greater.

Two **BVRAMB** ambient noise sensors can be wired in parallel on the same circuit; a 4K7 compensation resistor is fitted at the **BVRCI** card. See following fig 1 for typical connection details.

Fig 1

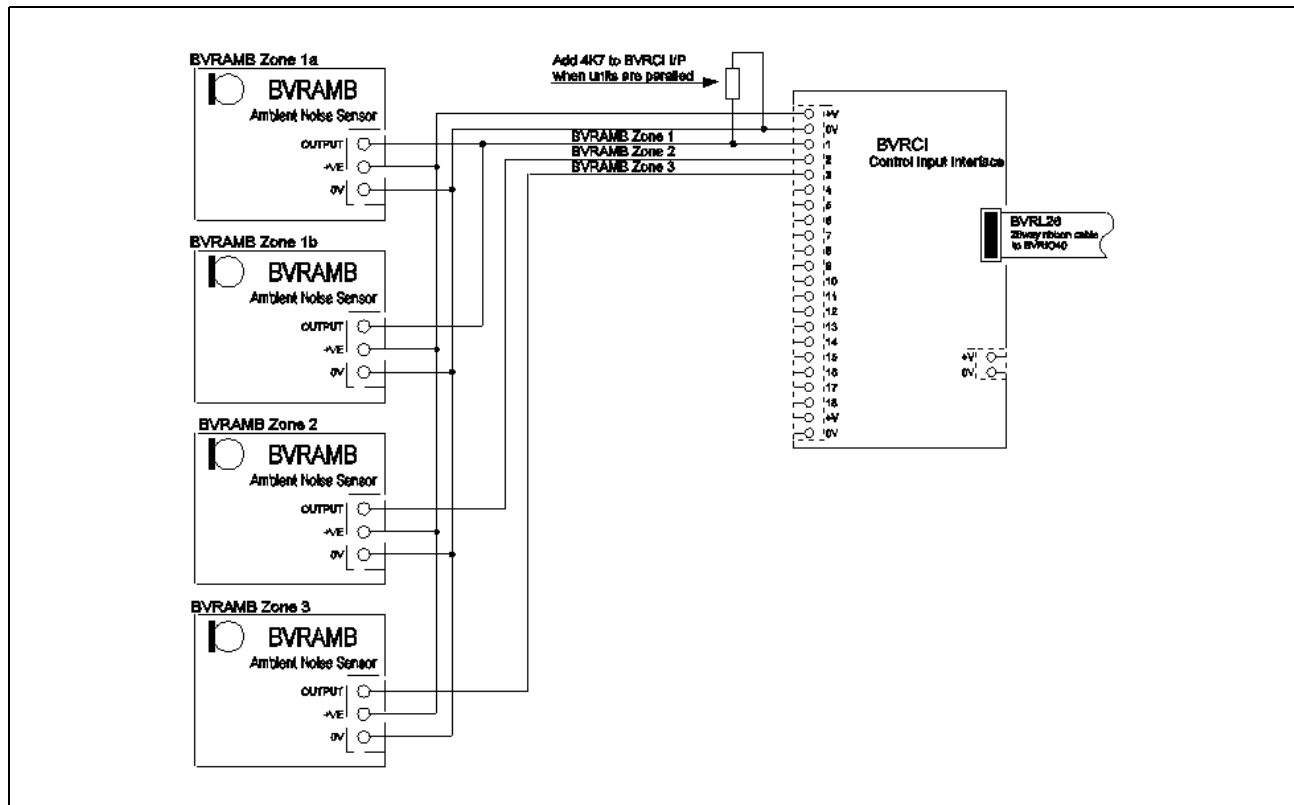

Setting Up

The Ambient Noise Sensing function is controlled either from the BVR20 front panel, or a Laptop Computer if the Configuration software is fitted. The following identifies the BVR20 LCD screens, and assumes that the user has access authority.

With the **System Configuration Keyswitch** in the **ON** position, press the **PAGE DOWN** key, the first page will identify the software version of the BVR20. Press **PAGE DOWN** again and enter **User Code**, press **PAGE DOWN** until you come to the first of the output pages, (fig 2).

Fig 2

OUT 01	in	01	02	03	04	05	06	07	08	09	10
	volume	00	00	00	00	00	00	00	00	00	00

Before setting the ANS level it is important to establish two points

1. Set the maximum output volume required in the ANS zone, that is the volume demanded to meet a fully populated area, or with maximum ambient noise i.e. a train waiting at the platform.
2. That the figure entered for **volume** is within the limits **10 to 15**, this will allow the ANS to enable a full dynamic movement of the output volume. It may be necessary to reduce the associated input gain using the volume and attenuator controls on the **INPUT** page. The example below shows output volumes entered for Fire Microphone One, Message One, and Message Two, (fig 3).

Fig 3

OUT 01	in	01	02	03	04	05	06	07	08	09	10
	volume	12	00	00	00	14	14	00	00	00	00

Operate **PAGE DOWN** key twice this will bring you to the ambient noise page for output one, (fig 4).

Fig 4

OUT 01	CHIME	SURV	A=10	B=10	ANS	(-00
	00	Out 10	2OK	A + B + Res	Sens	00

The right hand of the screen displays the two ambient noise sections. **ANS** displays the returned signal from the sensor; this is a dynamic figure and will vary between -00 and -12 with the ambient noise. The figure -00 represents no attenuation, whereas -12 represents the maximum (20dB) of attenuation.

Sens is the sensitivity of the noise sensor, the user enters this figure. The figure 00 will disable the ANS, i.e. OFF, maximum audio output. The figure 01 will enable the ANS and give the minimum sensitivity from the BVRAMB noise sensor; the maximum sensitivity that can be entered is 15, (fig 5).

Fig 5

OUT 01	CHIME	SURV	A=10	B=10	ANS	(-00)
	00	Out 10	2OK	A + B + Res	Sens	00

Before making adjustment to the ANS it is important that the Surveillance Monitored is switched off, otherwise the ANS will detect this as a signal and freeze the output.

Simply reduce **SURV Out** to read **00** (fig 6).

Fig 6

OUT 01	CHIME	SURV	A=10	B=10	ANS	(-00)
	00	Out 00	2OK	A + B + Res	Sens	00

Establish that the BVR20 is providing the maximum output as demanded by site conditions, and as described above.

In theory, if the ambient noise is at it's loudest, then the announcements should remain around 10dB above the ambient level. Once set the, the loudspeaker volume will automatically adjust to the ambient noise level in that zone, from maximum output or to a minimum of 20dB of attenuation, (fig 7).

Fig 7

OUT 01	CHIME	SURV	A=10	B=10	ANS	(-10)
	00	Out 10	2OK	A + B + Res	Sens	05

Note: Once settings have been adjusted, re-enter the original Surveillance Monitor (SURV) figure, always return the configuration key to the anti clockwise position.

Software Versions

BVR8-30. Released 25-10-2001

Faster response time from ANS sensors.

BVR8-43. Released 21-07-2003

Under high reverberation conditions it is possible that the level increase inhibit detector is not effective and the echo is sensed as ambient noise during pauses in the broadcast message. This run away is made more apparent if the sensor sensitivity is set too high and in a tunnel environment.

BVR8-43 allows the installer to select the freeze condition when the output has been selected i.e. the busy state.

As message 1, input 5 does not have the facility to select a chime, this is now used to select the ANS mode.

CHIME	OFF	Selects auto freeze when an output signal is detected at normal sensitivity.
CHIME	1-note	Selects auto freeze when an output signal is detected at normal sensitivity or if the output has a busy condition.
CHIME	2-note	Selects auto freeze when an output signal is detected at maximum sensitivity.
CHIME	3-note	Selects auto freeze when an output signal is detected at maximum sensitivity or if the output has a busy condition