

BVMX Mixer and
BVMS1 Mixer Output Module

Operating Instructions

Baldwin Boxall Communications Ltd.

Wealden Industrial Estate, Farningham Road
Crowborough, East Sussex, TN6 2JR

Telephone: 01892 664422 Fax: 01892 663146

Website: www.baldwinboxall.co.uk

Email: mail@baldwinboxall.co.uk

BALDWIN BOXALL
COMMUNICATIONS

BVMX MIXER

The BVMX will accept up to a maximum of 11 single width input or output modules, for example 10 input modules and 1 output module. A 6 way dual in line switch enables the signal buses to be isolated thus providing two independent output channels between module 5 and 6. Using this switch it is easy to realise a two output channel mixer with input modules occupying positions 1-4 and the output module in position 5, input modules in position 6-10 and the output module in position 11. It is possible to obtain further output channels by carefully drilling out the appropriate through hole connection adjacent to the pin of each input edge connector.

Two separate two pole changeover relays provide switching of external AC or DC signals up to 100V at 5 Amps maximum, for busy indicators, volume restoration relays etc. Also available on each 8 way connector is +24V and 0V at 1 Amp maximum to power external circuits. If "Rest" is selected "Off" on the DIL switch relay RLY1 will only operate from module sockets 1-5 and relay RLY2 will operate from 6-11. When the "Rest" is selected "On", both relays will operate from all module sockets. Please refer to data on IMP modules.

The BVMX obtains 24V DC power from a PSU/Charger BVPS and maybe powered by two separate sources to ensure operation. The mixer may also be used as a stand alone mixer and interfaced with other equipment. To power it use the BVMXPSU power supply. These supplies are presented by a two way crimp terminated locking connectors. Front panel LED indicators illuminate when the associated supply is present.

Depending on the input module fitted and the selection of its internal switches the audio output signal may be routed to one of two bus lines. The output module type number BVMS1 has a virtual earth mixer stage connected to each of these audio signal paths. It is possible by switch selection to achieve priority on audio highway PA Pin No 5 Channel 1 over audio highway Channel 2 on Pin No 4. Channel 1 the priority channel incorporates a switchable low pass filter at 12KHz and the output may be routed direct to the output or via the bass and treble control. Channel 2 incorporates a high pass filter switchable at 300Hz and its output is routed via the tone controls to the output. Each channel has its own independent master gain control which are presented on the front panel. The access terminal of the rear panel connector that the output stage occupies may be switched to either:

1. A pre-fade output from channel two for tape recording,
2. DC controlled access channel one over channel two, connect to 0V to enable channel 1,
3. An unbalanced audio output when this module is fitted in the standard Adept amplifier main frame,
4. DC controlled remote volume when the remote volume control option is fitted.

Three four way connectors enable options to be inserted in the following positions:

- A. Channel 1 before the master gain control J2.
- B. Channel 2 before the master gain control J3.
- C. After the bass and treble control stage J4.

Another four way connector J1 is provided which enables the use of the virtual earth mixing stages as buffers to feed additional output stages, for example a system that requires a number of ambient noise sensors feeding independent areas. Switches associated with the input of the virtual earth amplifier provide the correct attenuation when used in this mode.

Each output module has 4 LEDs to indicate the output level, 5% 50% 100% and 120% the nominal output level i.e. 100% is 0.775V but signals to a maximum of 2.5V is possible.

SW2 SWITCH FUNCTIONS

1. **PRI** - set to 'ON' for priority.
Channel 1 when accessed will override Channel 2.
Note: to access Channel 1 select ACC switch 'ON' and connect access terminal to 0V.
Set 'OFF' to mix both channels together.
2. **LP** - set 'on' to by pass the 12KHz low pass filter on Channel 1.
3. * **OUT** - set to 'ON' to provide an unbalanced output from the access terminal or output to feed the power amplifier when fitted in an Adept mixer amplifier.
Note: set (4) ACC and (5) PF to 'OFF'.
4. * **ACC** - set to 'ON' for priority access. Used in conjunction with PRI above.
Note:- set (3) OUT and (5) PF to 'OFF'.
5. * **PF** - set to 'ON' to provide a prefade output from Channel 2 for tape recording etc.
Note: set (3) OUT and (4) ACC to 'OFF'.
6. **TC** - set to 'ON' to route Channel 1 direct to the output, not via the bass and treble controls. Note: set (8) TC to 'OFF'.
7. **HP** - set to 'ON' to bypass the 300Hz high pass filter on Channel 2.
8. **TC** - set to 'ON' to route Channel 1 via the Bass and Treble controls.
Note: set (6) \overline{TC} to 'OFF'.

* ONLY SET ONE SWITCH TO THE 'ON' POSITION

SW1 SWITCH FUNCTIONS

1. Set to 'ON' for virtual earth (summing) input, normal mixing mode on Channel 2.
Set to 'OFF' for high impedance input, when used in the buffer mode.
2. Set to 'ON' for virtual earth (summing) input, normal mixing mode on Channel 1.
Set to 'OFF' for high impedance input, when used in the buffer mode.

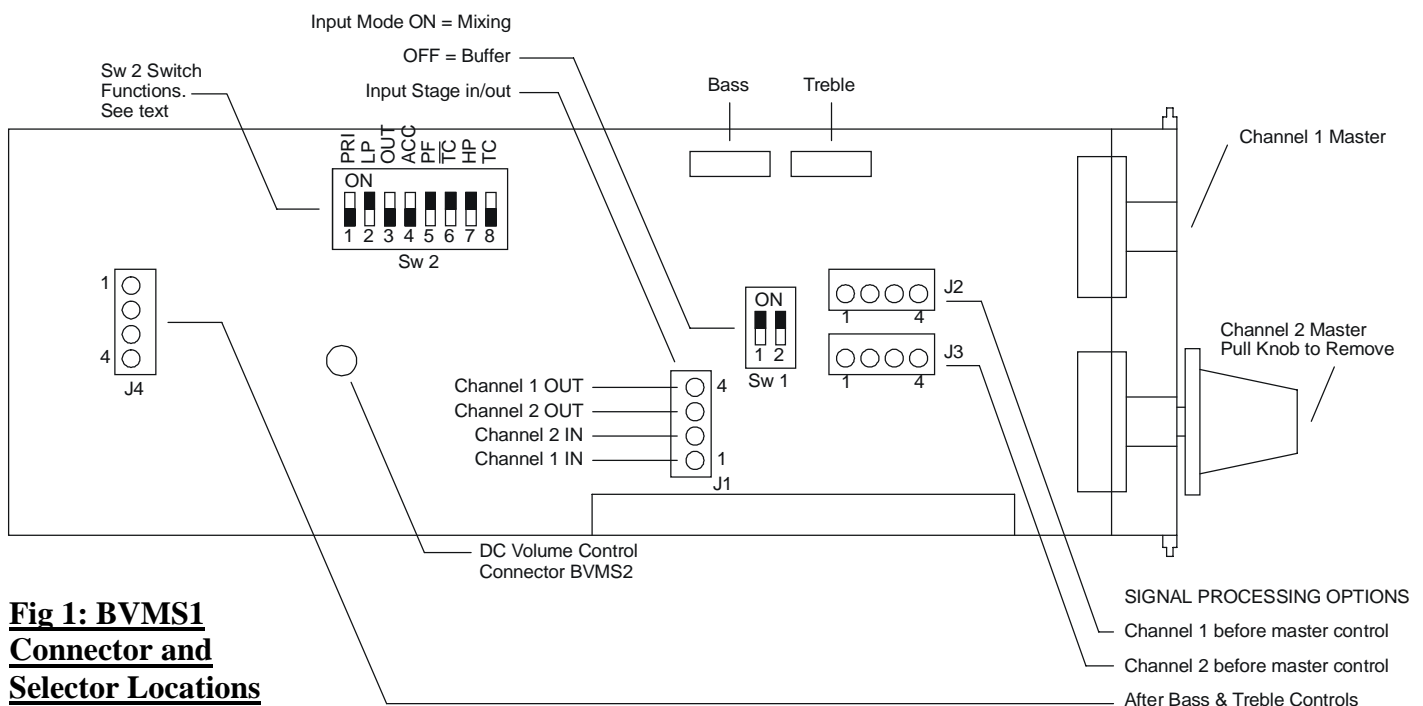

**Fig 1: BVMS1
Connector and
Selector Locations**

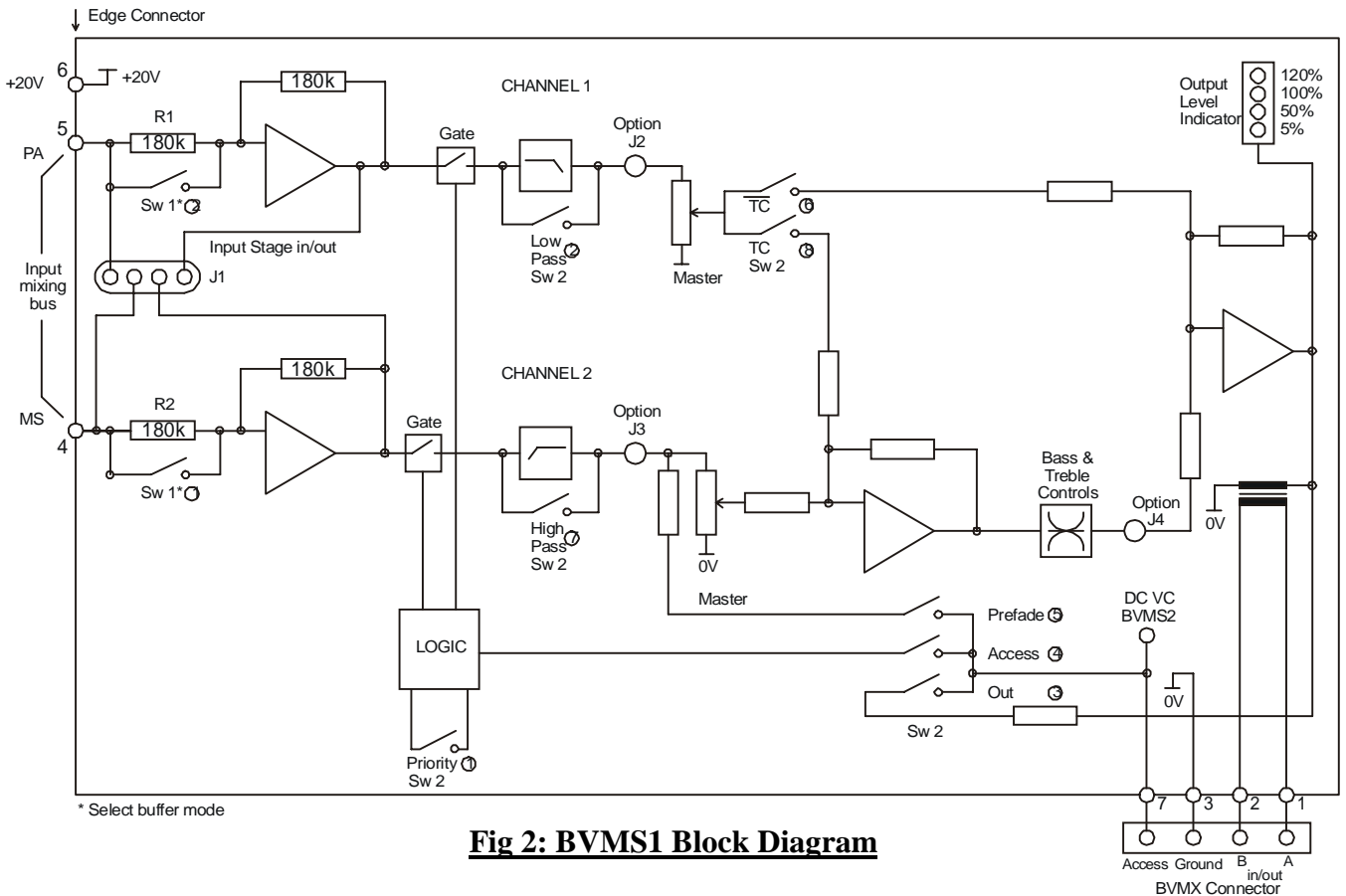

Fig 2: BVMS1 Block Diagram

The BVML Module

The BVML module allows external access to the internal Priority, Busy and Chime bus lines within a BVMX mixer mainframe. This enables equal (first come first serve) priority to be achieved when multiple mixers are used.

As the internal bus employs static sensitive logic devices the BVML incorporates the essential protection components.

A BVMS1 mixer module is required in each of the BVMX mainframes to obtain the audio output. We do not recommend or provide the facility to parallel the low level virtual earth mixing, audio bus lines from one BVMX to another, due to hum, noise and instability problems that could occur. Mixing of the BVMS1 outputs is easily achieved by connecting them in series.

The BVML occupies one module space and presents the internal bus on the 4-way BVMX connector shown below.

BVMX Rear Panel Connector	BVMX Internal Bus
A	Busy
B	Chime
0V	0V
Access	Priority in/out

Figure 5 illustrates a system using three BVMX linked via BVML providing 25 microphone inputs, one having total priority, 24 with first come first serve priority and an IMP33 pre-announcement chime.

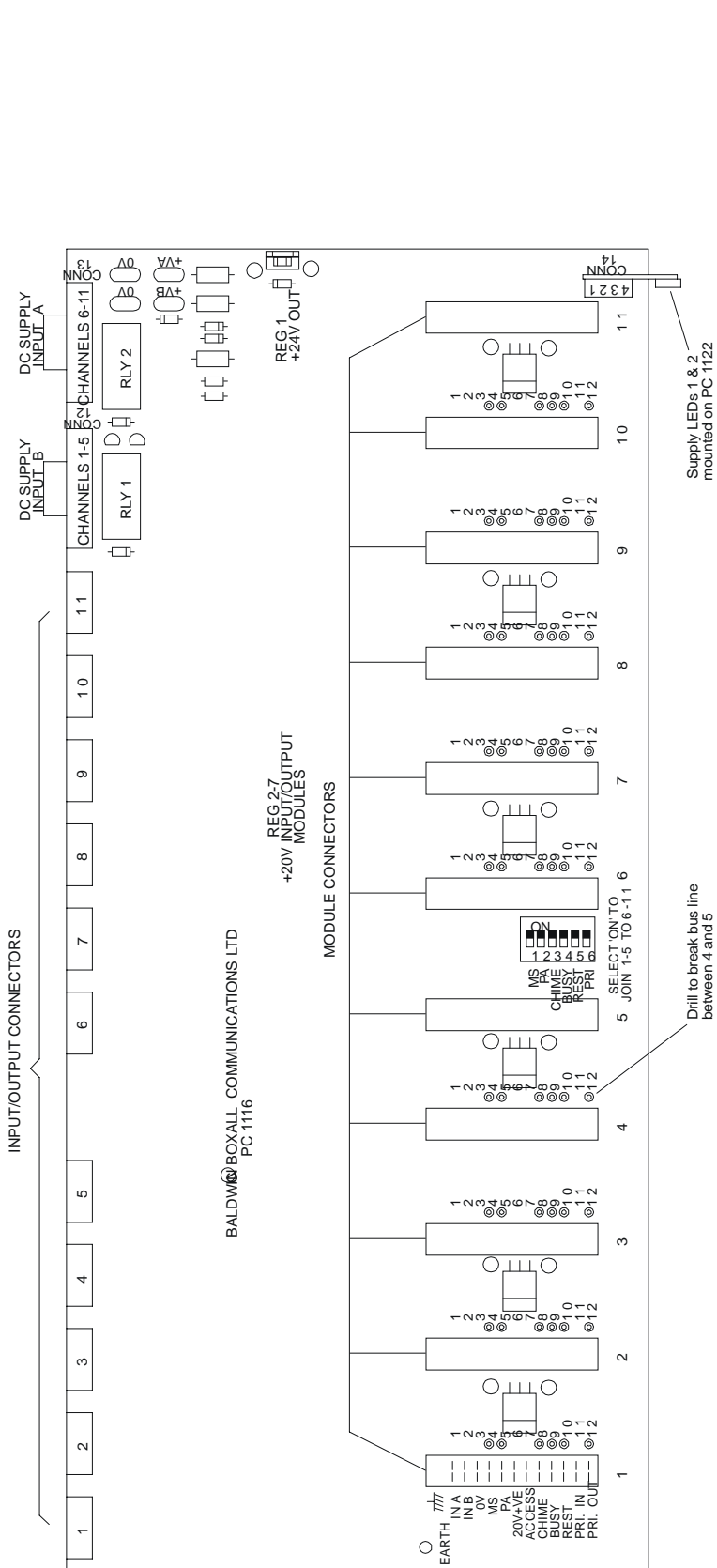
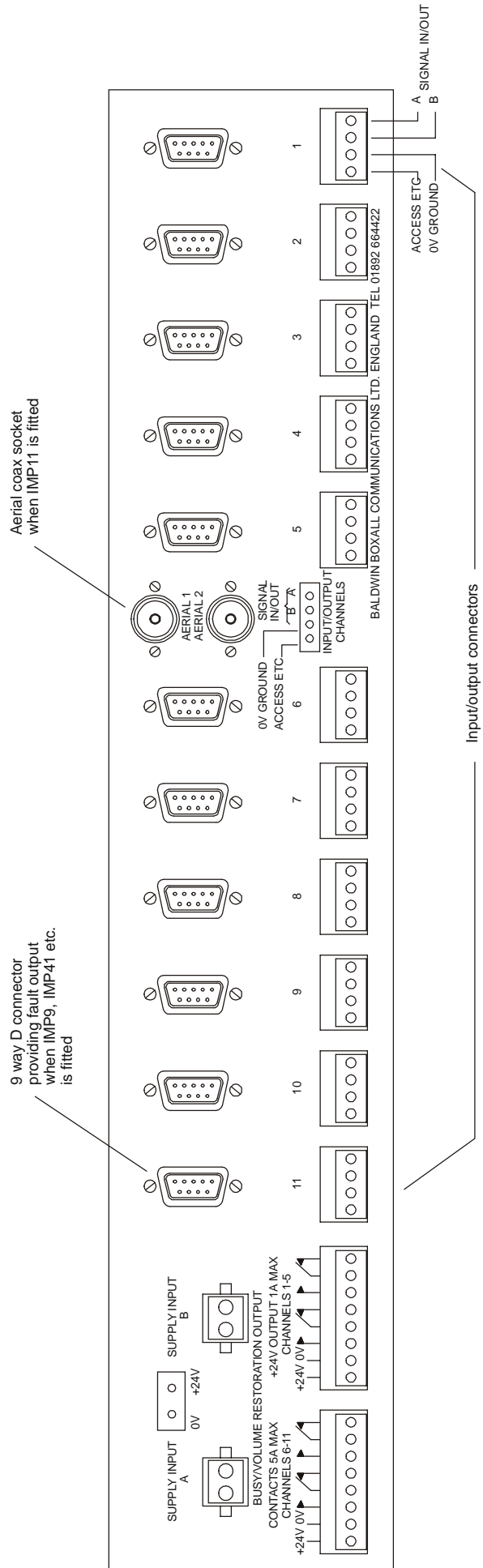

Fig 3 (above): BVMX Plan View

Fig 4 (right): BVMX Rear View



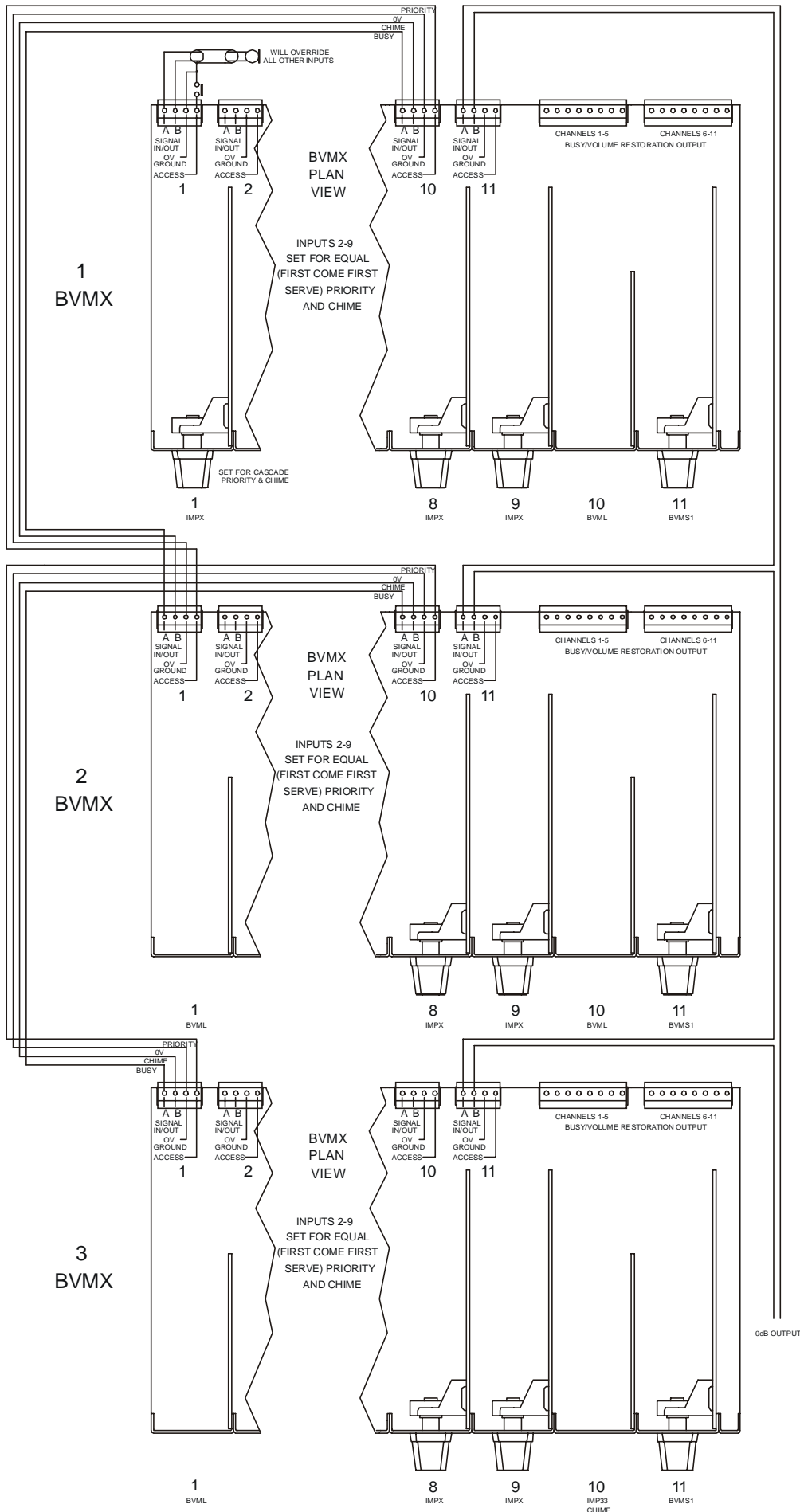

Fig 5: Connection details for Three BVMX Mixers linked via BVML Modules, providing 25 Microphone Inputs with Chime