

# **BV440M**

# **Operating Instructions**

**Baldwin Boxall Communications Ltd.**  
Wealden Industrial Estate, Farningham Road  
Crowborough, East Sussex, TN6 2JR

Telephone: 01892 664422  
Fax: 01892 663146  
Website: [www.baldwinboxall.co.uk](http://www.baldwinboxall.co.uk)  
Email: [mail@baldwinboxall.co.uk](mailto:mail@baldwinboxall.co.uk)

**BALDWIN BOX▲LL**  
C O M M U N I C A T I O N S

## **VIGIL BV440M**

The Vigil 2 BV440M is a Class “D” Power amplifier, with two 500mV Balance Line audio inputs and a single 440 Watt 100V Line output.

The front panel status indicators show “Supply Healthy”, “Overload”, “Over Temperature” and Output Level (10% and 100% max output level).

The “Active” Indicator illuminates when the amplifier is not in Sleep Mode.

CLASS D amplifiers are 80% efficient therefore reducing unwanted heat dissipation and power input requirements. Rated output power is obtainable using a 22V battery supply. The BV440M has a Sleep mode automatically reducing the standby current requirement to typically 70mA per amplifier when operating on batteries.

The BV440M is equipped with two 500mV balanced line inputs incorporating a priority switching system.

The priority is selected using a 4-way dip switch.

Switch 1 when selected “on” provides input 2 muting when 1 is accessed.

Switch 2 when selected “off” enables the first input irrespective of access conditions.

When both switches are selected “on” Input 1 will override input 2, therefore it is possible to have both inputs mixing together or cascade priority depending on the requirements.

Channel gain may be individually set using the potentiometers on the board behind the front panel.

Switches 3 & 4 set unit to Master when both “ON”, when both “OFF” the unit is a Slave.

The audio inputs to the amplifier are presented on two separate RJ45 connectors; each connector providing both balanced audio inputs, ground and access control inputs.

The output is presented on a 3-way plug/screw termination connector providing 50V or 100V output.

The 24V DC input (together with the interface connections which enable amplifier modules to be paralleled) are presented on a 6-way crimp connected plug and socket.

A maximum of three BV440M modules can be paralleled to produce higher single zone output powers.

The power output stage of the amplifier is protected against overload conditions (i.e. short circuits or abnormal loads etc). Should the amplifier be subjected to an abnormal load the input to the power amplifier is attenuated to a safe level. The amplifier’s output voltage is also sensed and should it exceed 100V the input signal will be attenuated ensuring safe operation without creating unnecessary distortion.

Over temperature protection is provided using a sensor attached to the output stage heat sink. Should the temperature exceed 90 Degrees Celsius the input signal will be attenuated to a safe level and the “Overtemp” LED will be illuminated.

If the system is under surveillance it will cause the surveillance detector to indicate a fault condition due to the gain reduction.

Each BV440M Amplifier is normally mounted in one BVMF equipment frame with a BVSMP switched mode power supply / charger module.

## **BV440 Specification**

Rated output power less than 0.2% THD	440W @ 22.7 Ohms
Typical output power less than 1% THD	520W @ 19.3 Ohms
Output regulation 440W @ 22.7 Ohms	Better than 1.4 dB
Output Voltages obtainable	50 & 100V
Frequency response 440W @ 22.7 Ohms	35 Hz – 20 kHz
Input sensitivity and impedance	500mV @ 40kOhms balanced
Input common mode rejection ratio (50Hz – 30kHz)	Better than 40 dB: typically 60 dB
Output noise reference to rated output	Better than 85 dB
Supply Voltage	22 – 35V DC

### Supply current:

Sleep mode 26V battery	70mA
Quiescent 30V supply	250mA
Rated output power	20A

### Output stage protection:

Thermal	Output stage above 90 °C
Load	Output stage current
Action	Reduces input to a safe level using a low distortion voltage controlled attenuator

### Front panel indicators:

Supply	DC supply connected
Temperature alert	Output stage above 90 °C
Overload	Protection circuit operating
Active	Amplifier is active, not in sleep mode
100% output	100V output Voltage
10% output	10V output Voltage

Lamp test switch for the above indicators

### Terminations:

Loudspeaker line output	1 off 3 pin screw terminated connector
Balanced line inputs	2 off RJ45 8 pin connectors
DC supply input and paralleling facility	6 pin crimp terminated connector

# Front Panel and Internal Controls

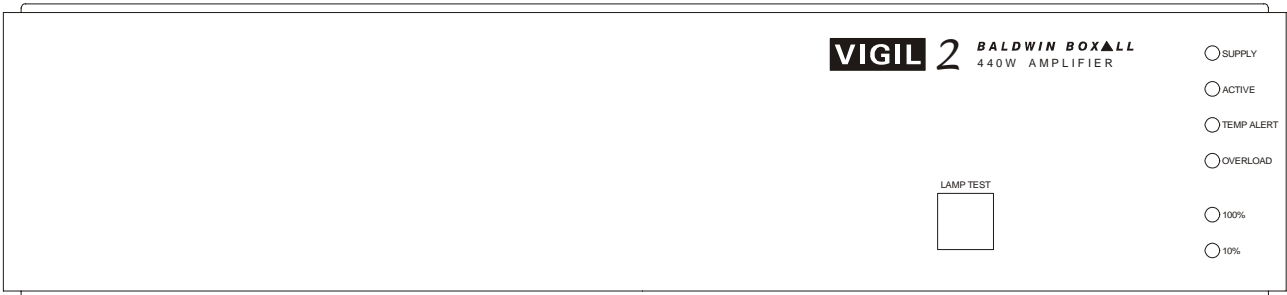

Adjust For Input 1  
Signal Gain

Adjust For Input 2  
Signal Gain

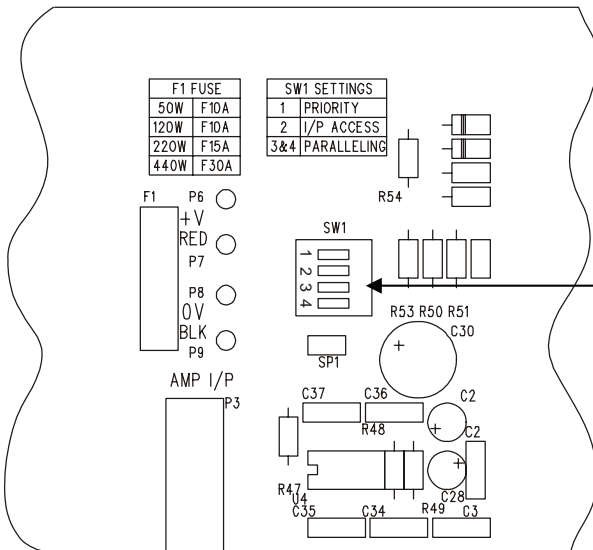
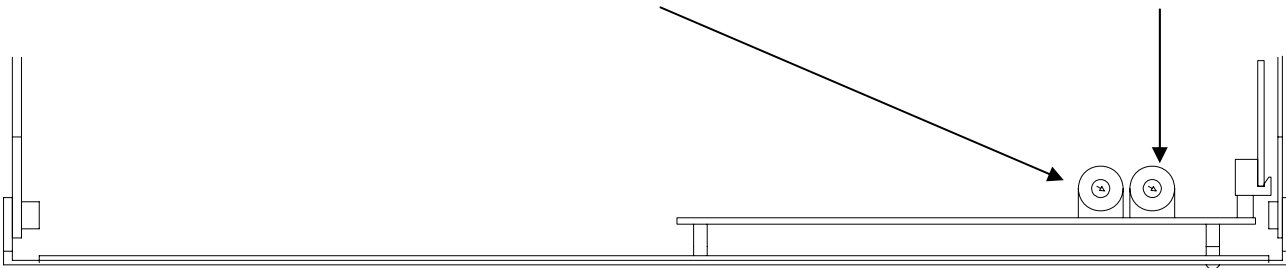

### Default Switch Settings

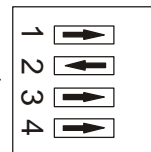

Sw 1.- On  
2 - Off  
3 - On  
4 - On

### Slave Switch Settings

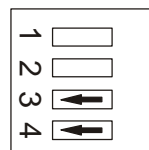

Sw 3 - Off  
4 - Off

When Paralleling Amplifiers make sure that the control Amplifier is set to Master and all subsequent Amplifiers are set to slave.

## Rear Panel

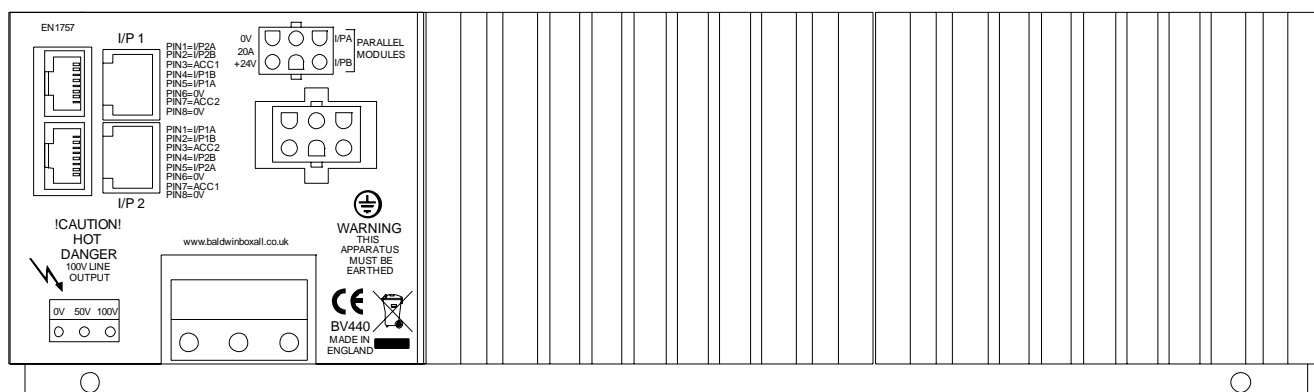

### RJ45 Input Connector Details

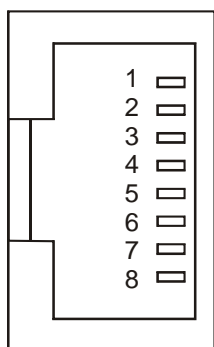

Pin #	Wire Colour	I/P Connector #1	I/P Connector #2
1	Orange / White	Audio Input 2A	Audio Input 1A
2	Orange	Audio Input 2B	Audio Input 1B
3	Green / White	Access Input 1	Access Input 2
4	Blue	Audio Input 1B	Audio Input 2B
5	Blue / White	Audio Input 1A	Audio Input 2A
6	Green	0V	0V
7	Brown / White	Access Input 2	Access Input 1
8	Brown	0V	0V

### Connection details if using a “QLCONV” RJ45 Conversion Lead

The QLCONV lead enables an amplifier with RJ45 input connections to be used in an existing system without modifying the system wiring.

The Conversion lead can be used on both input positions on the BV440M and changes the input configuration to a 4 way screw terminal.

The terminations are shown below as they would appear when the QLCONV is connected to one of the inputs on the BV440M.

Ident	Wire Colour	RJ45 Pin	Input # 1 Connector	Input # 2 Connector
ACCESS	Green / White	3	Access Input 1	Access Input 2
0V	Green	6	0V	0V
I/P B	Blue	4	Audio Input 1B	Audio Input 2B
I/P A	Blue / White	5	Audio input 1A	Audio Input 2A

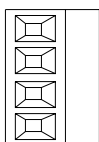

## Connections required if Multiple Amplifiers are using a Single Audio Source

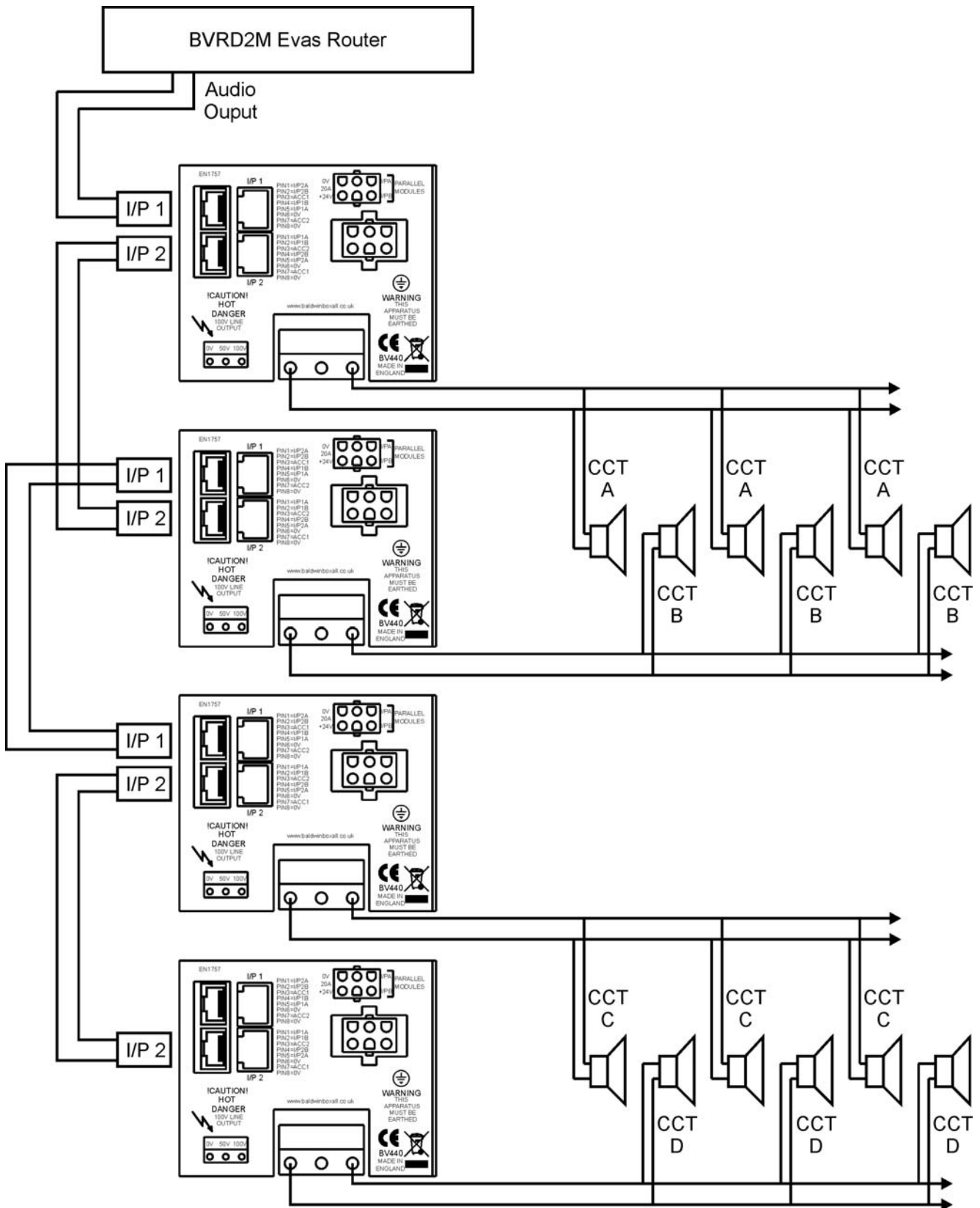

## Connections required for Paralleling Amplifiers

