

M2120E Amplifier



Operating Instructions

Baldwin Boxall Communications Ltd.

Wealden Industrial Estate, Farningham Road
Crowborough, East Sussex, TN6 2JR

Telephone: 01892 664422

Fax: 01892 663146

Website: www.baldwinboxall.co.uk

Email: mail@baldwinboxall.co.uk

BALDWIN BOXALL
COMMUNICATIONS

SAFETY

IMPORTANT NOTES - DO'S AND DON'TS

Ventilation

Always ensure adequate ventilation to the amplifier.

Do not obstruct the ventilation holes in the cover or base.

Should the amplifier exceed its safe operating temperature it will automatically reduce its volume to a safe level thus allowing it to cool. Once cooled it will operate normally without manual resetting.

AC Power Input - Danger High Voltage

Only connect to an AC 50-60 Hz 230V supply using the lead assembly supplied or an equivalent type with a suitable IEC connector.

Always ensure that the amplifier is earthed.

Always unplug the power before removing the top cover.

100V Loudspeaker Output - Danger High Voltage

Ensure that the loudspeaker connections are suitably protected and cannot be touched. Always replace output plug insulated covers.

Always ensure that the total speaker load does not exceed the rating of the amplifier used.

If unsure use an impedance meter to measure the unknown load.

Using a multimeter selected to the resistance range ensure that the speaker line is not connected to earth.

Moisture

Do not allow water to come in contact with the amplifier and its external connections.

Cable Types

Always ensure that the correct cable type is used for the signal level.

A twin screened cable should be used for balanced inputs operating at mic or line level. Zone selection and access control cables do not generally require screening and should not share the same screen as the balanced input.

Loudspeaker output cables should be rated in excess of 100V and the cross sectional area to suit the load without excessive power loss.

Always ensure that output cables are kept as far away from input cables as possible reducing the risk of instability.

Fuses

Always replace using the correct rating and type to ensure safe operation.

M2120E USER INSTRUCTIONS

The M2120E is an integrated 5 input 120 Watt free standing or rack-mounting amplifier powered from a 230 Volt AC supply. Each of the 5 inputs has separate volume, bass and treble controls. An output level 4 bar LED display indicates at 5% 25% 50% and 100% output.

Both low impedance and 100 Volt line outputs are available on a 4 pin Speakon connector, (pair 1+ and 1- being 100V and pair 2+ and 2- being low impedance), see fig 1 for connection details. The low impedance output is unbalanced ref to ground, suitable for driving 4 off 8 Ohm speakers connected in parallel or any other combination providing that the resulting impedance is no lower than 2 Ohms.

The 100 Volt line output is derived from a transformer that provides a fully floating output. If a balanced output is required the centre tap may be connected to ground via a link on the Speakon printed circuit board, see fig 2.

The power output stage is protected against overload conditions, i.e. short circuits etc., by sensing the current and voltage and presenting this error signal to a drive limiter circuit. Should the amplifier be subjected to an abnormal load the input to the power amplifier is limited to a safe level. Over temperature protection is also provided using a sensor attached to the output stage heatsink. Should the temperature exceed 90 C then the input signal is reduced to a low level preventing permanent damage to the amplifier.

Each of the 5 inputs can be set to either balanced Mic sensitivity (20-600 Ohm, 0.6mV) or balanced Line sensitivity (80mV) using the relevant DIL switch on the rear panel. These switches also control the Phantom Power facility (20V DC) for each input. See fig 3 for details on these switch settings.

Input 5 can use either 2 Phono connectors to enable a compact disk or cassette tape machine to be easily connected, or if this feature is not required then a DIL switch is provided to switch the input to the XLR connector. See fig 3 for details on this switch setting.

Inputs 1 to 4 are provided with input gating and to use any input the relevant input access must be closed to 0 Volts, even if priority is not selected. When priority is selected using the DIL switches on the rear panel, the relevant input will override all descending; i.e. input 1 will override inputs 2, 3, 4 and 5. See fig 3 for details on these switch settings. Please note that input 5 is permanently accessed and therefore has no input access connection.

The open collector busy output will become active i.e. conduct to 0 Volts to operate relays, busy indicators etc, only if the priority is selected and input accessed. The busy output is protected by a 500mA self resetable fuse. A +24 Volt output is provided to power auxiliary equipment and is protected by a 1 Amp self resetable fuse.

An OPT 33 chime module may be fitted to sound when an input is accessed. Please note that the chime will only sound with priority selected on the desired input or by closing the chime trigger input to ground. The chime pre-set volume and DIL switch to select 1, 2, or 3 notes are mounted on the OPT 33.

Optional signal processing (i.e. Bose loudspeaker equaliser OPTEQ) may be incorporated using the internal connector provided, see fig 5 for details on mounting this option.

Additional external equipment (e.g. a graphic equaliser) can be inserted between the preamplifiers and power amplifier by removing the jumper link from the POWER AMP INPUT and PRE AMP OUT phono connectors on the rear panel.

The external equipment should have an input impedance greater than 5K Ohms and output impedance lower than 2K Ohms with a nominal level of 800 mV.

M2120E Integrated Technical Specification

Rated output power 100V line 230V AC supply	120W 83 Ohms
THD 1 kHz rated output Aux input 230V AC supply	Less than 0.5% typically 0.2%
Typical output power 1% THD Aux input 230V AC supply	100V line 150W 66 Ohms Low Z - 80W 4 Ohms Low Z - 130W 2 Ohms
Output regulation (1 kHz 100V line)	Better than 1dB
Output voltages obtainable (Pin selection)	100V & low impedance
Supply voltage AC	220 – 240V 50 – 60 Hz
Power consumption @ 230V Quiescent Rated output power @ 1kHz	18VA 300VA
Fuse protection 1 x AC supply 20 x 5mm 2 x DC (amplifier) auto blade type 1 x 24V DC output 1 x DC “Busy” open collector output	3.15A(T) 10A(F) 1A Self resetable 500mA Self resetable
Aux input phono stereo summed mono Sensitivity Frequency response – 3dB Signal to noise ratio	100mV @ 20K Ohms Better than 40 Hz – 20 kHz Better than 80 dB
Tone controls Bass Treble	± 12 dB @ 100 Hz ± 12 dB @ 12 kHz
Universal input (line) Sensitivity Frequency response – 3dB Signal to noise ratio	80mV @ 12K balanced Better than 40 Hz – 18 kHz Better than 70 dB
Universal input (Mic) Sensitivity	600µV balanced
Input impedance Without phantom power With phantom power 20V	12k Ohms 660 Ohms
Frequency response – 3dB	Better than 40 Hz – 18 kHz
Common mode rejection ratio 50 Hz – 30 kHz	Better than 60 dB
Signal to noise ratio terminated 200 Ohms	Better than 60 dB
LED indicators	Output level indicator 5%, 25%, 50% & 100%
Terminations AC supply input Aux signal input Universal input Input Access Loudspeaker output	3-pin DIN IEC 6A 2 x phono, stereo summed mono 3-pin XLR 6-pin screw terminal connector 4-pin Speakon connector
Fan assisted	No
Dimensions (mm) (D x W x H)	340 x 430 x 90
Weight	12 kg

SPEAKON LOUDSPEAKER OUTPUT CONNECTIONS

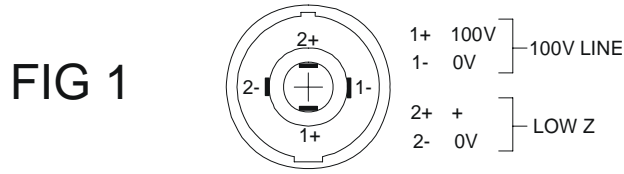

BALLANCED 100V LINE SELECTION

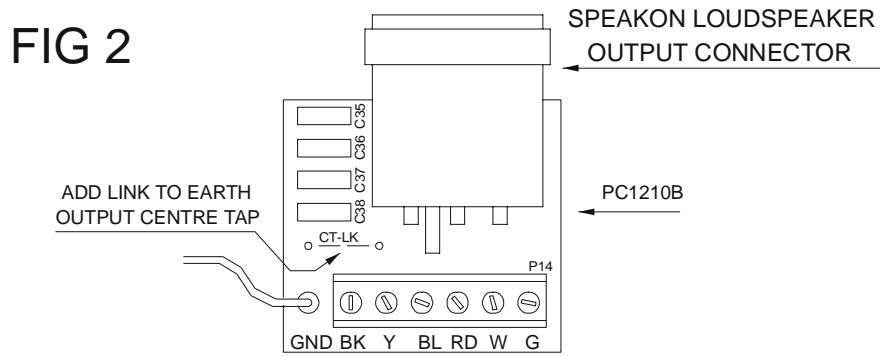

FIG 3 DIL SWITCH (1 PER INPUT)

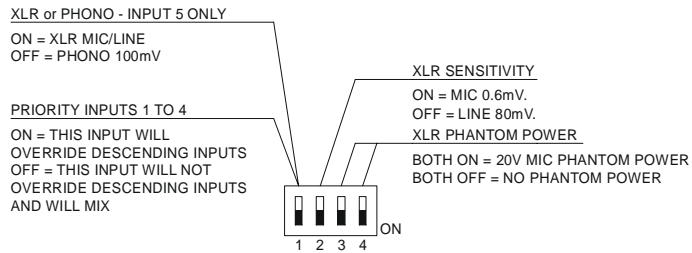
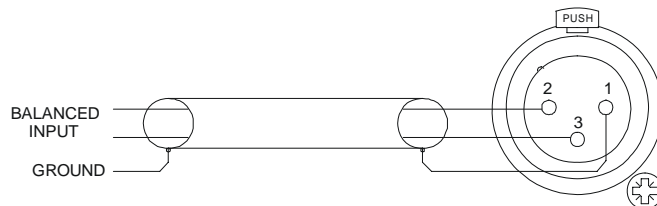
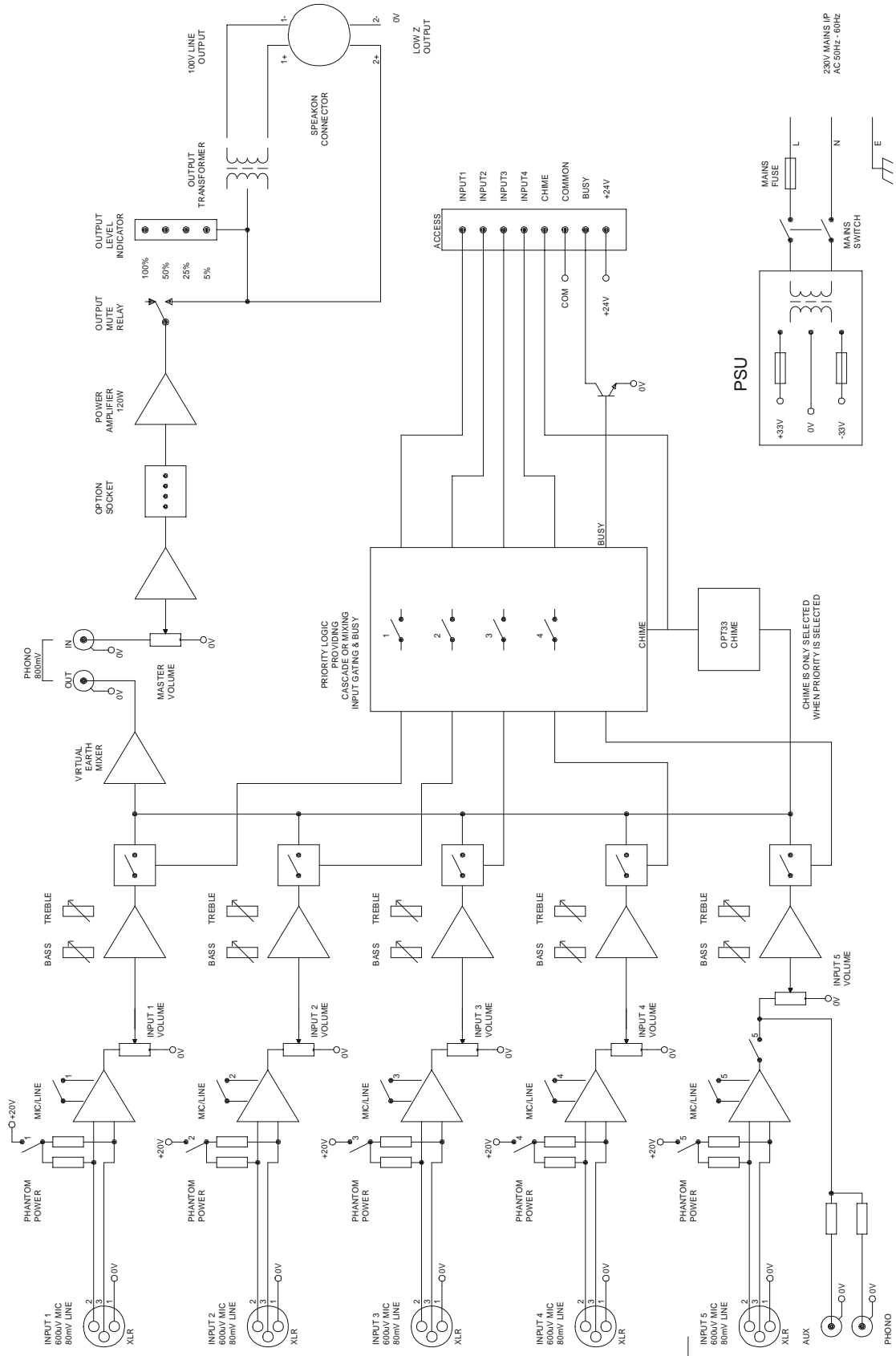

FIG 4 XLR INPUT CONNECTIONS



M2120E BLOCK DIAGRAM



M2120E Front and Rear Panel Illustration

