

**BT8**

# Operating Instructions

**Baldwin Boxall Communications Ltd.**

Wealden Industrial Estate, Farningham Road  
Crowborough, East Sussex, TN6 2JR

Telephone: 01892 664422 Fax: 01892 663146

Website: [www.baldwinboxall.co.uk](http://www.baldwinboxall.co.uk)

Email: [mail@baldwinboxall.co.uk](mailto:mail@baldwinboxall.co.uk)

**BALDWIN BOXALL**  
COMMUNICATIONS

## BT8 PHONE PAGER

Connecting the telephone system to the Public Address makes the paging facility available to all. It gives everyone the opportunity to contact other members of staff easily and quickly - this avoids the need to contact reception and asking them to put out a call.

The BT8 is designed for use both with phones that have MF signalling and those that do not.

1. With MF signalling.

Ability to select up to 8 zones.

Live messages can be broadcast.

Messages can be recorded and then replayed which avoids any problems of howl-round i.e. feedback when the phone being used is adjacent to a loudspeaker.

The recorded message can be replayed either once or twice. This is determined by using an internal selector.

All of the above facilities are selected on the phone keypad.

2. Without MF signalling.

Single zone only.

Messages can be live or recorded. This is determined using an internal selector.

Recorded messages can be 55 seconds long. When used in the “live” mode, the call will be terminated automatically after 2.5 minutes.

The BT8 is either connected to a designated 2 wire analogue extension port via a master line jack unit or can be connected directly to the paging port that is supplied by many telephone switches.

The output is at microphone or line level and is via a 25 way D connector that is compatible with our desk microphones and plugs into a BMS25 socket box (supplied with the BT8).

The unit has 2 L.E.D. indicators for “Mains ON” and “Amplifier Accessed”.

This product is not suitable for connection to a keyphone extension.

### **Busy Input (if required)**

If the public address amplifier is busy the BT8 will receive a 20 - 30 V DC supply on pins 22 and 23 of the D connector which will send the normal busy (engaged) tone to the caller.

**N.B. The amplifier input into which the BT8 is connected must not provide a busy condition.**

When using the busy facility with a Mitre or Adept amplifier it is necessary to connect a 24 V DC supply to pin 23 of the BMS25.

This 24V DC supply may be obtained from either pin 6 of the relevant input connector on Mitre, or from pin 5 of the amplifier sub socket on Adept.

Connect pin 22 on the BMS25 to pin 5 of the relevant input connector on Mitre, or pin 4 of the sub socket on Adept – these are taken to 0v when the amplifier is busy.

### **PLEASE NOTE**

*The BT8 is not approved for direct connection to the British Telecom network and therefore must never be directly connected. However under general approval NS/G/23/J100003 it may be connected to a port of a telephone switch (PABX).*

## INSTRUCTIONS WHEN PHONE HAS MF SIGNALLING

### To Record a message for Broadcast

1. Caller dials into the designated extension number.
2. Caller will hear normal ringing. After 2 rings the BT8 is ready for the message. If the amplifier is busy the normal busy tone is heard.
3. A zone or zones is selected using keypad keys 1-8. An “all call” will be selected automatically if no zones are chosen. If the caller mis-dials, pressing “0” will reset the system.
4. To record the message momentarily press # and then talk into the handset clearly and slowly.  
**N.B.** If A mistake is made the recording can be terminated by pressing “0”.
5. When recording is completed the caller presses any key except “0” and the announcement will be played through the P.A. system.
6. Caller replaces handset.  
**N.B.** There is an internal DIL switch for deciding if the recording plays back once or twice.

### To Repeat Last Recorded Message

1. Caller dials into the designated extension number.
2. Caller will hear normal ringing. After 2 rings the BT8 is ready. If the amplifier is busy the normal busy tone is heard.
3. A zone or zones is selected using keypad keys 1-8. An “all call” will be selected automatically if no zones are chosen. If the caller mis-dials, pressing “0” will reset the system.
4. Press key “9” and the previously recorded message will be replayed. This avoids having to re-record the message.
5. Caller replaces handset.

### To Make A “Live” Broadcast

1. Caller dials the designated extension number.
2. Caller will hear normal ringing. After 2 rings the BT8 is ready for the message. If the amplifier is busy the normal busy tone is heard.
3. A zone or zones is selected using keypad keys 1-8. An “all call” will be selected if no zones are chosen. If the caller mis-dials, pressing “0” will reset the system.
4. Caller presses the \* key momentarily. The caller then speaks directly into the P.A.system.  
**N.B.** Care must be taken if the amplifier has a pre-announcement chime. The system does not have chime acknowledgement or have a speak now tone indicator. Therefore you must wait for 3 seconds to allow the chime to finish before making your announcement. This will avoid talking over the chime.
5. On completion of the message the caller presses any key to terminate the call.
6. Caller replaces handset.

## **INSTRUCTIONS WHEN THE PHONE DOES NOT HAVE MF SIGNALLING**

When using the BT8 with phones that do not have MF signalling the following steps have to be taken:

SW2 must be selected to 'ON'.

SW3 must be set for either 'Live' or 'Recorded' messages to be broadcast.

Using SW3 select as follows :-

OFF            Live messages broadcast.

ON             Recorded messages broadcast.

### **To Make A "Live" Broadcast (SW3 set to 'OFF')**

1. Caller dials the designated extension number.
2. Caller will hear normal ringing. After 2 rings the BT8 is ready for the message to be broadcast. It is unnecessary to press any numbers on the keypad.

**N.B.** Care must be taken if the amplifier has a pre-announcement chime. The system does not have chime acknowledge or have a speak now tone indicator. Therefore you must wait for 3 seconds to allow the chime to finish before making your announcement. This will avoid talking over the chime.

3. On completion of the message wait 2 seconds and replace the handset, to avoid any unwanted noises in the speakers.

### **To Record a message for Broadcast (SW3 set to 'ON')**

1. Caller dials the designated extension number.
2. Caller will hear normal ringing. After 2 rings the BT8 is ready for the message. If the amplifier is busy the normal busy tone is heard.
3. Caller speaks.
4. Caller replaces the handset.  
The message will be broadcast through the PA System.

## **BASIC FAULT FINDING**

- 1 *Problem:* If user makes a mistake during recording they replace the receiver and the engaged tone is heard through the system for 55 seconds.  
*Answer:* Change the engaged tone to continuous. The BT8 recognises an intermittent engaged tone as a voice and holds up. An alternative is to arrange for an interruption in the line current.
- 2 *Problem:* User does not like the 2 second delay before being able to speak.  
*Answer:* Connect BT8 on to the paging port of the telephone switch.
- 3 *Problem:* User makes a recording but when playing it back it only plays for two seconds.  
*Answer:* Remove the 'busy' – the amplifier is 'busying out' the BT8.
- 4 *Problem:* Some feature phones hold up the BT8 preventing it from releasing.  
*Answer:* Arrange for the telephone switch to give a 'COD' (Clear On Disconnect). This will release the BT8

**FIG. 1 - Connecting to a 2 wire analogue extension port**

Ensure that LK1 and LK2 are fitted and with selector switch SW1, set 4 to off.

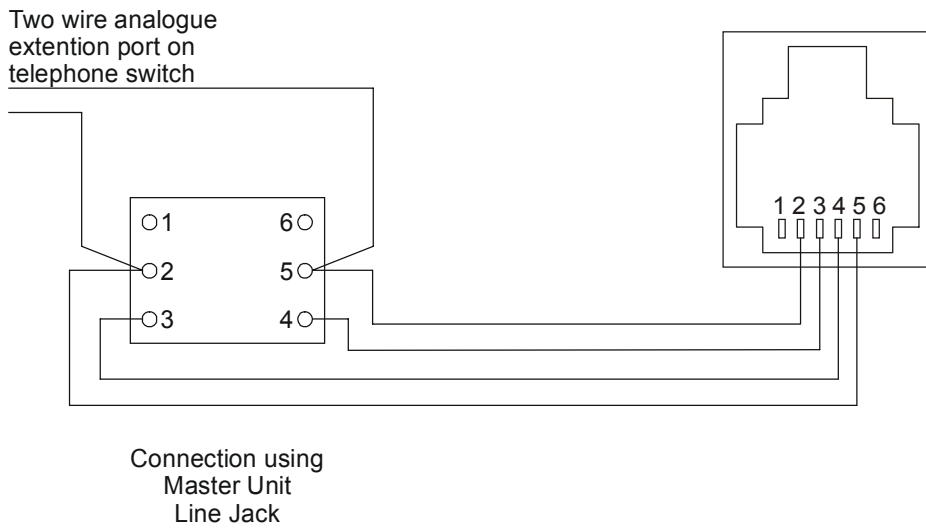

**FIG. 2 - BT8 Connections to a paging port**

When the BT8 is interfaced with a paging port, certain steps have to be taken to reconfigure the unit. Remove links LK1 and LK2. Then reposition the links onto links LK3 and LK4. On selector switch SW1, select 4 ON.

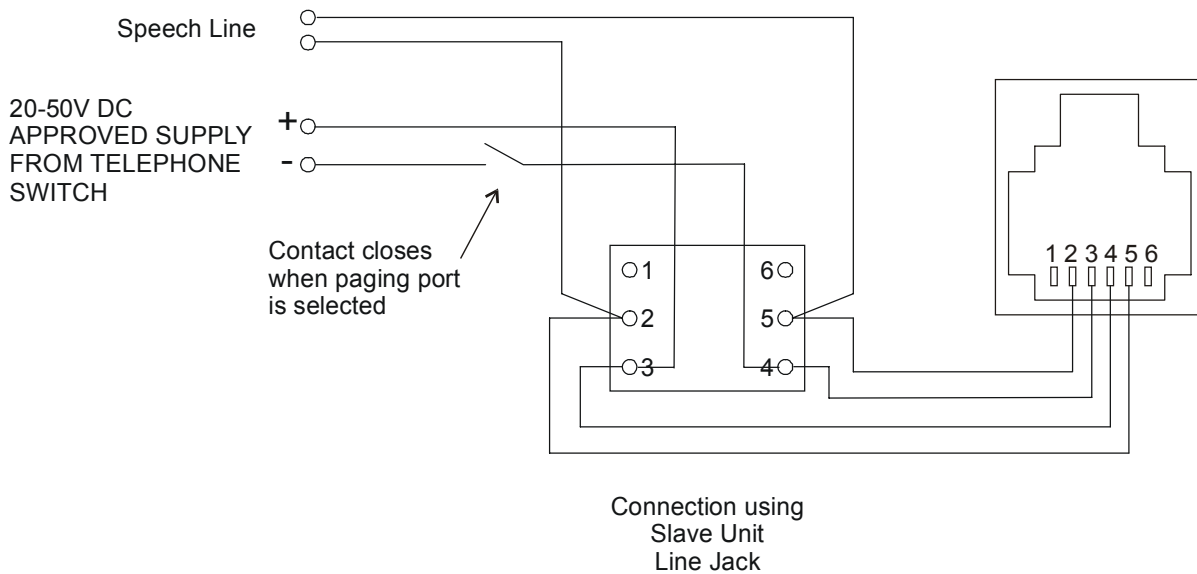

## BT8 TECHNICAL SPECIFICATION

### LINE CONNECTIONS

RING VOLTAGE : 20-70V 17-25Hz  
 REN VALUE : 1.0

### CLEARDOWN (By either of the following)

K Break : Interruption of line current  
 Voice Operated Switch : Absence of caller speaking  
 Dial Tone Detector : 350-440Hz from telephone switch  
 DTMF Tone : Sent from caller to terminate the call  
 Time Out : Recorded 55 secs, live 2.5 minutes

### AUDIO CONNECTIONS

Zone Select Outputs 8 off : NPN open collector 40V @ 100mA max  
 Amplifier Access Output 1 off : NPN open collector 40V @ 100mA max  
 Amplifier Busy Input : Opto coupled 12-30V 7mA max AC/DC  
 Mic Output Level : 2.5mV  
 Mic Level Source Impedance : 22ohms  
 Line Output Level : 0dBm 775mV  
 Line Output Source Impedance : 220 ohms

AC SUPPLY INPUT : 220-240V 50/60 Hz

Fuse Protection : 20 x 5mm 250mA(T)

### AMPLIFIER CONNECTIONS

<u>FUNCTION</u>	<u>BMS 25 CONNECTIONS</u>
ZONE 1	1
ZONE 2	2
ZONE 3	3
ZONE 4	4
ZONE 5	5
ZONE 6	6
ZONE 7	7
ZONE 8	8
Mic Output Level 2.5mV Floating	16
Cable Screen - Connect to 0V	17
Mic Output Level 2.5mV Floating	18
0V	19
Access Amplifier - NPN Open Collector Output 40V @ 100mA Max.	21
Busy Input - Opto-Coupled 12-30V 7mA Max AC/DC.	22
Busy Input - Opto-Coupled 12-30V 7mA Max AC/DC.	23
Line Output Level 775mV Floating	24
Line Output Level 775mV Floating	25

**FIG. 3 - BT8 Switch Settings and Link Locations**

